



## **Packet Guide**

*This is not the agenda.*

*Please click each agenda item below to link directly to the corresponding documents.*

5:00 **Pre-Meeting Discussion**

5:30 **Regular Meeting**

**A. Matters from the public not on the agenda (please limit to 3 minutes per speaker)**

**B. Consent Agenda** (Note: Any consent agenda item may be pulled and moved to the regular agenda if a BAR member wishes to discuss it, or if any member of the public is present to comment on it. Pulled applications will be discussed at the beginning of the meeting.)

1. **Certificate of Appropriateness**

BAR 21-07-01

854 Locust Avenue, Tax Parcel 510092000

Martha Jefferson Historic Conservation District

Owner: Kaitlyn and Alan Taylor

Applicant: Ashley Davies

Project: Garage construction

2. **Certificate of Appropriateness**

BAR 21-07-02

734 Locust Avenue, Tax Parcel 510073000

Martha Jefferson Historic Conservation District

Owner: Kathleen D. Free

Applicant: Barbara Gehrung

Project: Carriage house alterations

**C. New Items**

5:40 3. **Certificate of Appropriateness**

BAR 21-07-03

743 Park Street, TMP 520052000

North Downtown ADC District

Owner: Amita Sudhir and Aaron M. Freilich

Applicant: Zach Snider, Alloy Architecture & Construction

Project: Remove metal siding and repair/replace original wood siding; storm window replacements

- 6:20 4. **Certificate of Appropriateness**  
BAR 21-07-05  
350 Park Street, TMP 530109000 and 530108000  
North Downtown ADC District  
Owner: City of Charlottesville and County of Albemarle  
Applicant: Eric Amtmann, Dalgliesh-Gilpin-Paxton Architects [on behalf of  
Albemarle County]  
Project: New courthouse building (at Levy Building)

**D. Discussion Items**

- 7:00 5. **BAR 16-11-01**  
401 Cherry Avenue, TMP 290150000  
Owner: Gateway Terrace Partners, LLC  
Representative: Doug Stafford, Griffin-Stafford Hospitality  
Project: Repairs to stucco
6. Dead trees on Downtown Mall

**E. Other Business**

7. Staff questions/discussion
8. PLACE update

**F. Adjourn**

## **Certificate of Appropriateness**

BAR 21-07-01

854 Locust Avenue, Tax Parcel 510092000

Martha Jefferson Historic Conservation District

Owner: Kaitlyn and Alan Taylor

Applicant: Ashley Davies

Project: Garage construction

Application components (please click each link to go directly to PDF page):

- [Staff Report](#)
- [Historic Survey](#)
- [Application Submittal](#)

**City of Charlottesville  
Board of Architectural Review  
Staff Report  
July 20, 2021**



**Certificate of Appropriateness Application (Historic Conservation District)**

BAR 21-07-01

854 Locust Avenue, Tax Parcel 510092000  
Martha Jefferson Historic Conservation District  
Owner: Kaitlyn and Alan Taylor  
Applicant: Ashley Davies  
Project: Garage construction

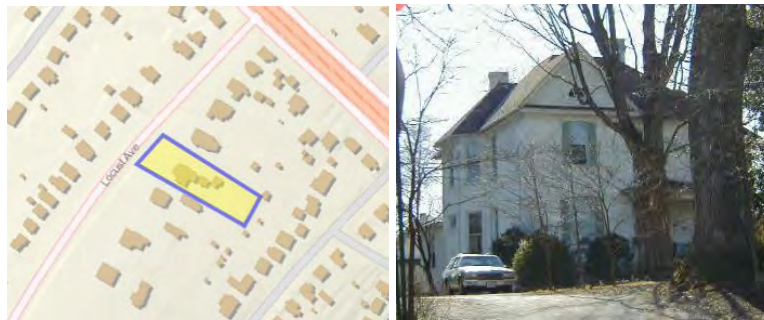

**Background**

Year Built: 1903  
District: Martha Jefferson HC District  
Status: Contributing

The property contains an imposing two-story painted-brick dwelling, constructed in 1903 for John S. White, a real estate lawyer. (Historic survey in applicant’s submittal.)

**Prior BAR Review**

September 2011 - BAR approved demolition of small cinder block addition (c1960) on the guest house, cinder block garage (c1960) attached to the barn, and open frame shed (c1970’s).

August 18, 2020 – BAR approved demolition of the guest house and cinder block garage.

Note: This had been on the June 15, 2021 agenda, but was deferred by the applicant prior to the meeting.

**Application**

- Applicant submittal: Bracey Designs drawings 854 Locust Avenue, dated June 17, 2021: Site Plan; Plans; Elevations (two sheets); and Renderings.

Request CoA for construction of a two-story, detached garage.

**Materials**

- Roof: Standing-seam metal. Painted to match the house roof.

- Walls: Brick lower walls (painted to match house) with painted (white) shiplap siding on the upper, shed dormers.
- Windows (West elevation, visible from Locust Ave): Single-lite, casement windows.
- Entry Doors: Full-lite. (Not visible from Locust Ave.)
- Garage Doors: Paneled.
- Light Fixtures:
  - Wall sconces at garage doors. Fixtures not specified.
  - Low wall lights at south elevation: (Not visible from Locust Ave.)
- Balcony and rail: Not specified. (Not visible from Locust Ave.)
- Fence: Wood painted. (Not visible from Locust Ave.)

**Discussion and Recommendations**

Note: The regulations and guidelines for projects within a Historic Conservation District (HCD) are, by design, less rigid than those for an ADC District or an IPP. The HCD designations are intended to preserve the character-defining elements of the neighborhoods and to assure that new construction is not inappropriate to that character, while minimally imposing on current residents who may want to upgrade their homes. Within the existing HCDs are buildings and/or areas that might easily qualify for an ADC District or as an IPP; however, in evaluating proposals within HCDs, the BAR may apply only the HCD requirements and guidelines.

Within an HCD, the design review prioritizes what is visible from the public right of way. New structures concealed by the principal structure from all abutting streets are exempt from BAR review. With that, the four sides of the proposed garage are of the same design and materials, staff will focus on the front elevation.

Staff recommends approval. (See comments below under *Pertinent Design Review Guidelines for New Construction and Additions.*)

**Suggested Motions**

*Approval:* Having considered the standards set forth within the City Code, including City Design Guidelines for Historic Conservation Districts, I move to find that the proposed garage at 854 Locust Avenue satisfies the BAR’s criteria and is compatible with this property and other properties in the Martha Jefferson Neighborhood Historic Conservation District, and that the BAR approves the application [as submitted.]

[...as submitted with the following conditions: ...]

**Criteria, Standards, and Guidelines**

Review Criteria Generally

Sec. 34-341 of the City Code. Criteria for approval

- a) In considering a particular application the BAR shall approve the application unless it finds:
  - 1) That the proposal does not meet specific standards set forth within this division or applicable provisions of the conservation district design guidelines; and
  - 2) The proposal is incompatible with the historic, cultural or architectural character of the conservation district in which the property is located.
- b) The BAR's review of the proposed new construction or addition to a building or structure shall be limited to factors specified in section 34-342. The BAR's review of the proposed demolition,

razing or moving of any contributing structure shall be limited to the factors specified in section 34-343.

- c) The BAR, or city council on appeal, may require conditions of approval as are necessary or desirable to ensure that any new construction or addition would be compatible with the scale and character of the historic conservation district. Prior to attaching conditions to an approval, due consideration shall be given to the cost of compliance with the proposed conditions.

Sec. 34-342 of the City Code. Standards for review of new construction and additions.

The following features and factors shall be considered in determining the appropriateness of proposed new construction and additions to buildings or structures:

- 1) Whether the form, height, scale, mass and placement of the proposed construction are visually and architecturally compatible with the site and the applicable conservation district;
- 2) The harmony of the proposed changes in terms of overall proportion and the size and placement of entrances and windows;
- 3) The impact of the proposed change on the essential architectural form and integrity of the existing building;
- 4) The effect, with respect to architectural considerations, of the proposed change on the conservation district neighborhood;
- 5) Any applicable provisions of the city's conservation district design guidelines.

### **Pertinent Guidelines for New Construction and Additions (Historic Conservation Districts)**

#### Building Location – setback and spacing

1. Align a new building close to the average building setback line on the same street, if established, or consistent with the surrounding area.
2. Maintain average spacing between buildings on the same street.

**Staff Comment:** Garages generally located along the parcel line and either to the side or behind a house are common within the district, especially at the northern end of Locust Avenue; with most listed as contributing structures. The 1920 Sanborn Map indicates a garage located to the rear of this property. (See image and map in the Appendix.)

#### Building Scale – height and massing

1. Keep the footprint, and massing of new buildings consistent with the neighborhood characteristics and compatible with the character of buildings on the same street.
2. Keep the height and width of new buildings within the prevailing average height and width. Exceptions up to 200% of the prevailing height and width may be approved by the BAR when contextually appropriate.
3. An addition needs to be perceived as an addition and therefore should not visually overpower the existing building in scale and design.
4. An accessory building should appear secondary to the main building in scale and design.
5. Larger buildings (commercial or multi-family) otherwise permitted by zoning should be designed and articulated to be compatible with the scale of the majority of adjacent buildings on the same street or block.

**Staff Comment:** The proposed garage complies with these conditions.

### Building Form – roofs and porches

1. Roof forms should reference contributing buildings on the same street or surrounding area. Other roof forms may be approved by the BAR when contextually appropriate.
2. If many of the contributing buildings on the same street have porches, then it is strongly recommended that the design of a new residence includes a porch or similar form of similar width and depth.

**Staff Comment:** The garage roof material and form are compatible with the HCD.

### Building Openings – orientation, doors and windows

1. A single entrance door (or main entrance of a multifamily dwelling) facing the street is recommended.
2. Window and door patterns and the ratio of solids (wall area) to voids (window and door area) of new buildings should be compatible with contributing buildings in the surrounding area.
3. Windows should be simple shapes compatible with those on contributing buildings, which are generally vertically oriented in residential areas.

**Staff Comment:** The garage is oriented towards the street. The arrangement and style of the doors and windows are compatible with the HCD.

### Building Materials and Textures

1. The selection of materials and textures for a new building should relate architecturally to the district, and should be compatible with and complementary to neighboring buildings.
2. Long-lasting, durable and natural materials are preferred, including brick, wood, stucco, and cementitious siding and standing seam metal roofs. Clear glass windows (VLT of 70% or more) are preferred.

**Staff Comment:** The proposed materials are compatible with the HCD. Per the HCD regs, the replacement of windows and doors does not require a CoA. For additions and the construction of small, auxiliary buildings, it is staff's interpretation that window and door specifications are not required for CoA approval. Relative to the provision for 70% VLT glass, in prior discussion the BAR established that this not be necessary or appropriate for residential projects. (The glass for most residential doors and windows typically has a VLT in the low 60s.) The proposed garage doors are compatible with the HCD, which features an eclectic range of styles and designs.

### Building Paint

1. Painting unpainted brick or other masonry is discouraged because it is irreversible and may cause moisture problems.

**Staff Comment:** Painted brick, siding and trim is compatible with the HCD. Concerns related to the painting of unpainted masonry are primarily due to its irreversibility and potential to damage historic masonry, particularly of brick and mortar construction prior to early part of the 20<sup>th</sup> century. This garage is new construction and the proposed painting is intended to compliment the painted brick of the existing house.

## Site

1. Fences or walls that abut a City street (or fences located in a side yard between a street and the front of the principal structure on a lot) should not exceed three and one-half feet in height.

**Staff Comment:** Not applicable. Proposed fence is behind the primary structure and not visible from Locust Ave. A CoA—and only an administrative CoA—is required only for fences located in the front and/or side yards and between the street and the front of the principle structure. (Ref. 34-346(1) and 34-340(a)(2))

## **Martha Jefferson Historic Conservation District**

### Architectural character-defining features:

1. Encourage one-story front porches;
2. Encourage garages to be located in the rear yards;
3. The levels of a building's stories should be consistent with those on surrounding structures with respect to the natural grade [for example, a first floor should not be raised so that it is higher than most surrounding first floors];
4. Do not exclude well-designed, new contemporary architecture [there may be a misconception that only historic-looking new buildings are permitted];
5. Encourage standing seam metal roofs;
6. Maintain and encourage tree canopy [Maintain the existing tree canopy and encourage new large shade trees];
7. The following Historic Conservation Overlay District Design Guidelines are especially pertinent:
  - a. Maintain neighborhood massing and form;
  - b. Encourage the use of sustainable materials;
  - c. Limit the height of fences in front yards to 3 ½ feet in height.
8. Regarding the future development of the hospital properties, the neighborhood's focus has been:
  - a. not to tear down the old houses; to encourage low density residential development north of Taylor Walk (with the suggestion that Taylor Street be reinstated);
  - b. to expect the High Street area to develop as a sensitively designed, high-quality, mixed use development;
9. Encourage good stewardship of Maplewood Cemetery.

**Staff Comment:** Proposed garage is located in the rear yard and features a standing-seam metal roof.



**Appendix**

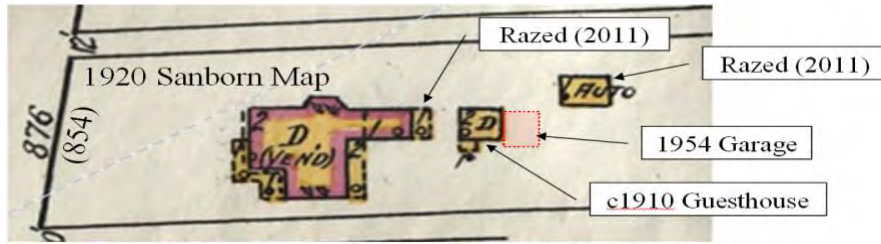

North section of Martha Jefferson HCD



# Architectural And Historic Survey



## Identification

<b>STREET ADDRESS:</b> 854 Locust Avenue	<b>HISTORIC NAME:</b> John S. White House
<b>MAP &amp; PARCEL:</b> 51-92	<b>DATE / PERIOD:</b> 1903
<b>CENSUS TRACT AND BLOCK:</b> 3-316	<b>STYLE:</b> Victorian
<b>PRESENT ZONING:</b> R-2	<b>HEIGHT (to cornice) OR STORIES:</b> 2 storeys
<b>ORIGINAL OWNER:</b> John S. White	<b>DIMENSIONS AND LAND AREA:</b> 97.35' x 360' avg. (35,046 sq.ft)
<b>ORIGINAL USE:</b> Residence	<b>CONDITION:</b> Good
<b>PRESENT USE:</b> Residence	<b>SURVEYOR:</b> Bibb
<b>PRESENT OWNER:</b> Charles A. Rausch, Jr., & Josephine S. Rausch	<b>DATE OF SURVEY:</b> Spring 1980
<b>ADDRESS:</b> 854 Locust Avenue Charlottesville, Virginia	<b>SOURCES:</b> City/County Records Mr. and Mrs. Charles A. Rausch, Jr.

## ARCHITECTURAL DESCRIPTION

This is a large irregularly shaped two-storey house, somewhat altered by the replacement of its two broad verandas with small entrance porches. It is set on a high foundation. Construction is of brick veneer laid in stretcher bond and now painted white. There are projecting side bays front and rear, a large projecting pavillion on the south side, and a one-storey kitchen wing. The high-pitched two-part hip roof has pedimented gables over the two projecting side bays. The roof is covered with standing-seam metal and has Philadelphia gutters, projecting eaves and verges, boxed cornice, and plain frieze. The gables are covered with wooden shingles, and each has a 1-light attic window, the one on the facade semi-circular. There are three interior capped chimneys; another in the kitchen wing has been removed. Windows are double-sash, 1-over-1 light, with wooden sills and green louvered shutters. Those at the second level are slightly shorter. All are rather narrow except those in the projecting bay of the facade. The window above the entrance was replaced with a pair of extremely narrow ones when a bath was added in the second storey hall. There is a shallow semi-octagonal one-storey bay window on the north side. The window in the center plane is short and high with leaded decorative glazing. There is a regular window in each side plane. Originally a wide one-storey veranda extended from the projecting bay on the facade, around the SW corner, and across the front of the south wing. A two-storey veranda covered the rear elevation, and one triple-sash window remains there. Both verandas have been reduced to one-bay entrance porches, and the upper level of the back porch was enclosed as a sleeping porch in the 1920's. Both front and back porches have low-pitched hip roofs covered with standing-seam metal, with boxed cornice, plain frieze, Tuscan columns, and Colonial Revival balustrade. The paired entrance doors have one light over two panels. There is a 2-light rectangular transom. A three-flight open stair rises from the entrance hall in the SW front corner of the house. A small, intricately designed, leaded stained glass window lights the second landing. There is a one-storey rear kitchen wing and a back porch with Eastlake posts and simple balustrade.

Behind the house there is a small, one-storey, 2-bay, single-pile white weatherboarded cottage with steep gable roof covered with composition shingles and a shed-roofed porch. It has a cinderblock addition at each end. It was originally used as servants' quarters.

## HISTORICAL DESCRIPTION

John S. White bought this lot in 1903 (ACDB 126-473) and built the house the same year. His family lived there for over 40 years. S. Vernon and Louise G. McCasland bought it from White's estate in 1946 (City DB 127-354). He was a religion professor at the University. In the eight years they lived there, they shortened the two verandas and removed the back stair. J. B. and Sally M. Hopkinson bought the house from the McCaslands in 1954 (DB 176-17). They made the additions to the cottage. The present owners bought the house in 1960 and have now lived there for twenty years. (DB 223-227).

## SIGNIFICANCE

This house is an excellent example of the Victorian style and one of the most important in the turn-of-the-century fabric of Locust Avenue.



1920 Sanborn 854 - 1-story porch cont across front of S wing, not around end.  
2-story porch cont across rear of S wing; upper bit missing 1929  
no bay on N  
brick veneer  
2-story cottage behind N a 1-story behind it, same 1969  
same 1929, 1969 - owner can prove porch is wrong on 1969 map.



**Board of Architectural Review (BAR)  
Conservation District - Certificate of Appropriateness**

Please Return To: City of Charlottesville  
Department of Neighborhood Development Services  
P.O. Box 911, City Hall  
Charlottesville, Virginia 22902  
Telephone (434) 970-3130

Please submit ten (10) hard copies and one (1) digital copy of application form and all attachments.

Please include application fee as follows: New construction project \$375; Demolition of a contributing structure \$375; Appeal of BAR decision \$125; Additions and other projects requiring BAR approval \$125; Administrative approval \$100. Make checks payable to the City of Charlottesville.

The BAR meets the third Tuesday of the month.

Deadline for submittals is Tuesday 3 weeks prior to next BAR meeting by 3:30 p.m.

Project Name/Description Garage Construction Parcel Number 510092000  
 Project Address/Location 854 Locust Avenue  
 Owner Name Alan & Bryant Taylor Applicant Name Ashley Davies

**Applicant Information**

Address: 455 2nd Street SE, Suite 201  
Charlottesville, VA 22902  
 Email: ashley@riverbenddev.com  
 Phone: (W) 434-245-4971 (H) 434-409-9127

**Property Owner Information (if not applicant)**

Address: 854 Locust Avenue  
Charlottesville, VA 22902  
 Email: alan@riverbenddev.com  
 Phone: (W) 434-245-4932 (H) 512-426-4728

**Signature of Applicant**

I hereby attest that the information I have provided is, to the best of my knowledge, correct.

*Ashley Davies* 3/26/2021  
 Signature Date

Ashley Davies 3/26/2021  
 Print Name Date

**Property Owner Permission (if not applicant)**

I have read this application and hereby give my consent to its submission.

*Alan Taylor* 3/26/21  
 Signature Date

Alan Taylor 3/26/2021  
 Print Name Date

**Description of Proposed Work (attach separate narrative if necessary):** See attached narrative  
Garage- new construction

**List All Attachments (see reverse side for submittal requirements):**

BAR Packets

**For Office Use Only**

Received by: \_\_\_\_\_ Approved/Disapproved by: \_\_\_\_\_  
 Date: \_\_\_\_\_  
 Fee paid: \_\_\_\_\_ Cash/Ck. # \_\_\_\_\_ Conditions of approval: \_\_\_\_\_  
 Date Received: \_\_\_\_\_  
 Revised April 2017

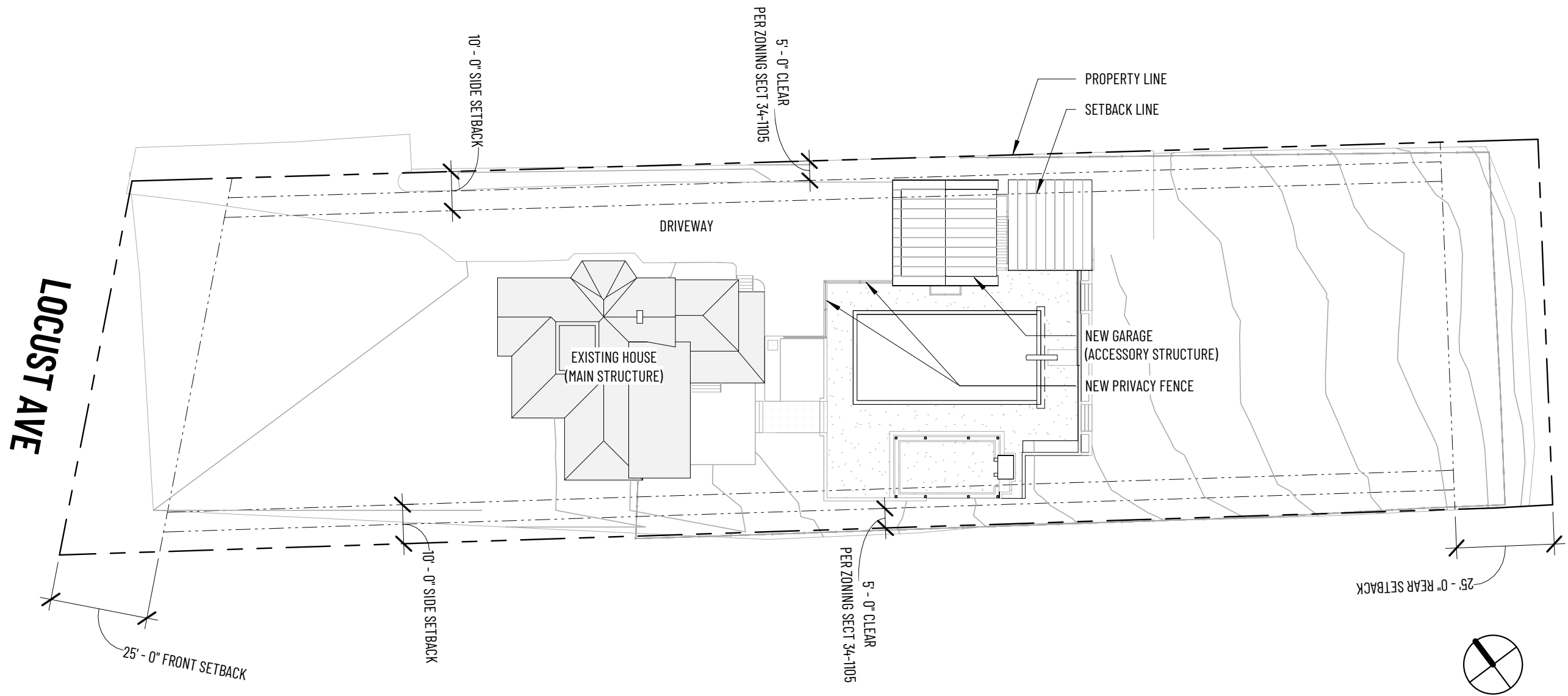

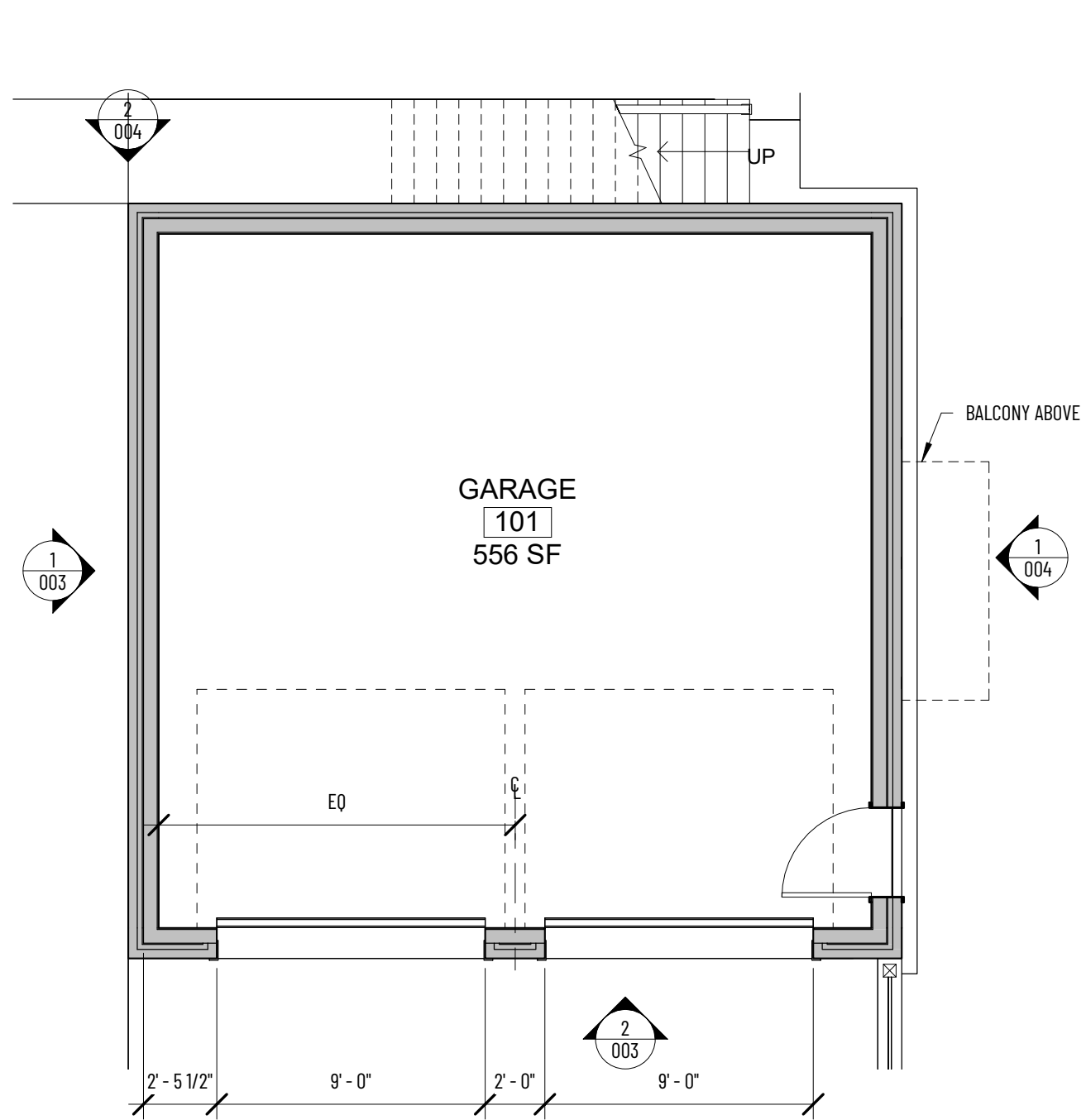

**1** Garage - Level 01

3/16" = 1'-0"

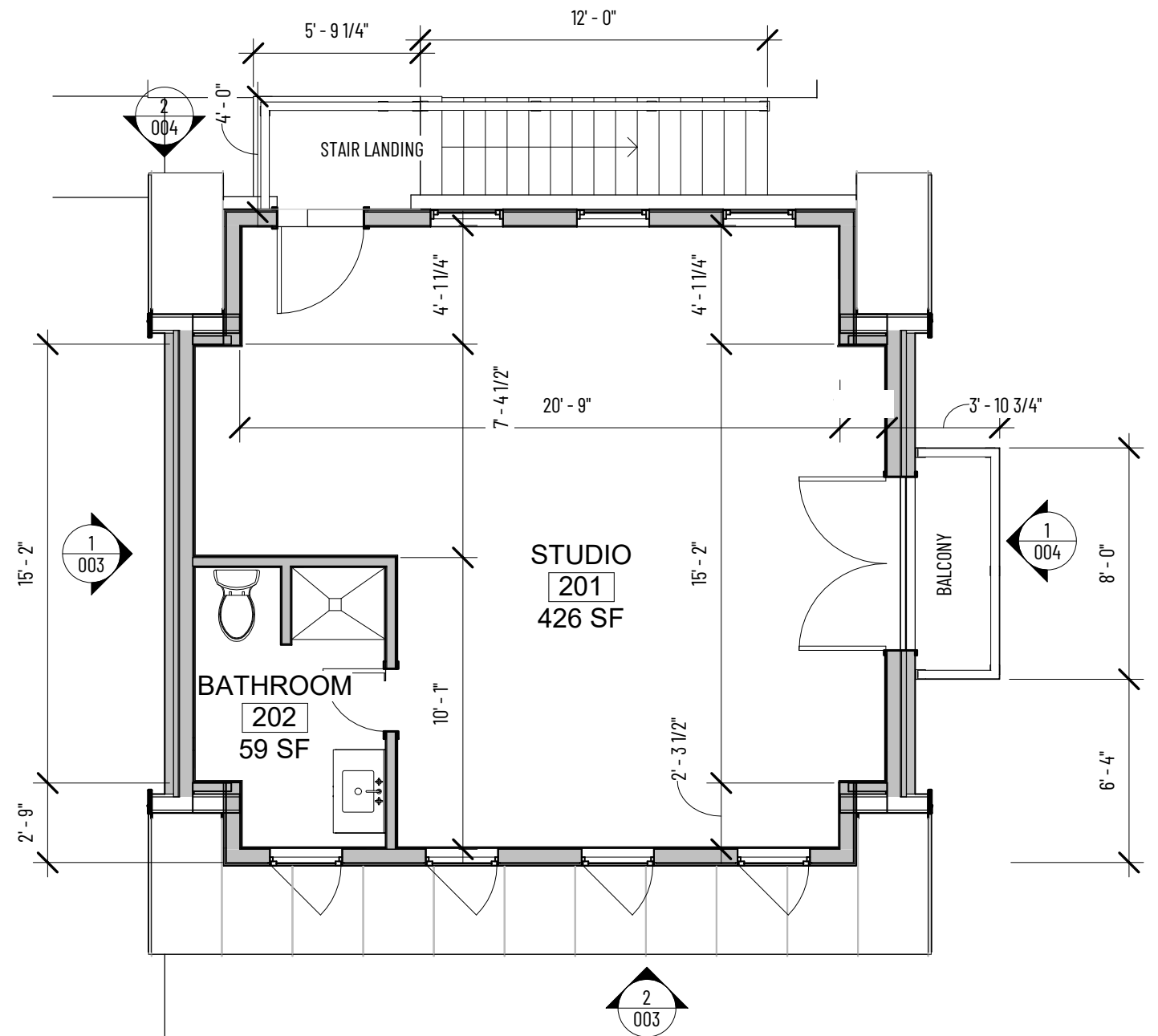

**2** Garage - Level 02

3/16" = 1'-0"



854 LOCUST AVE - Plans

Scale: 3/16" = 1'-0"  
6/17/2021 4:32:37 PM

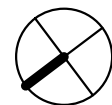

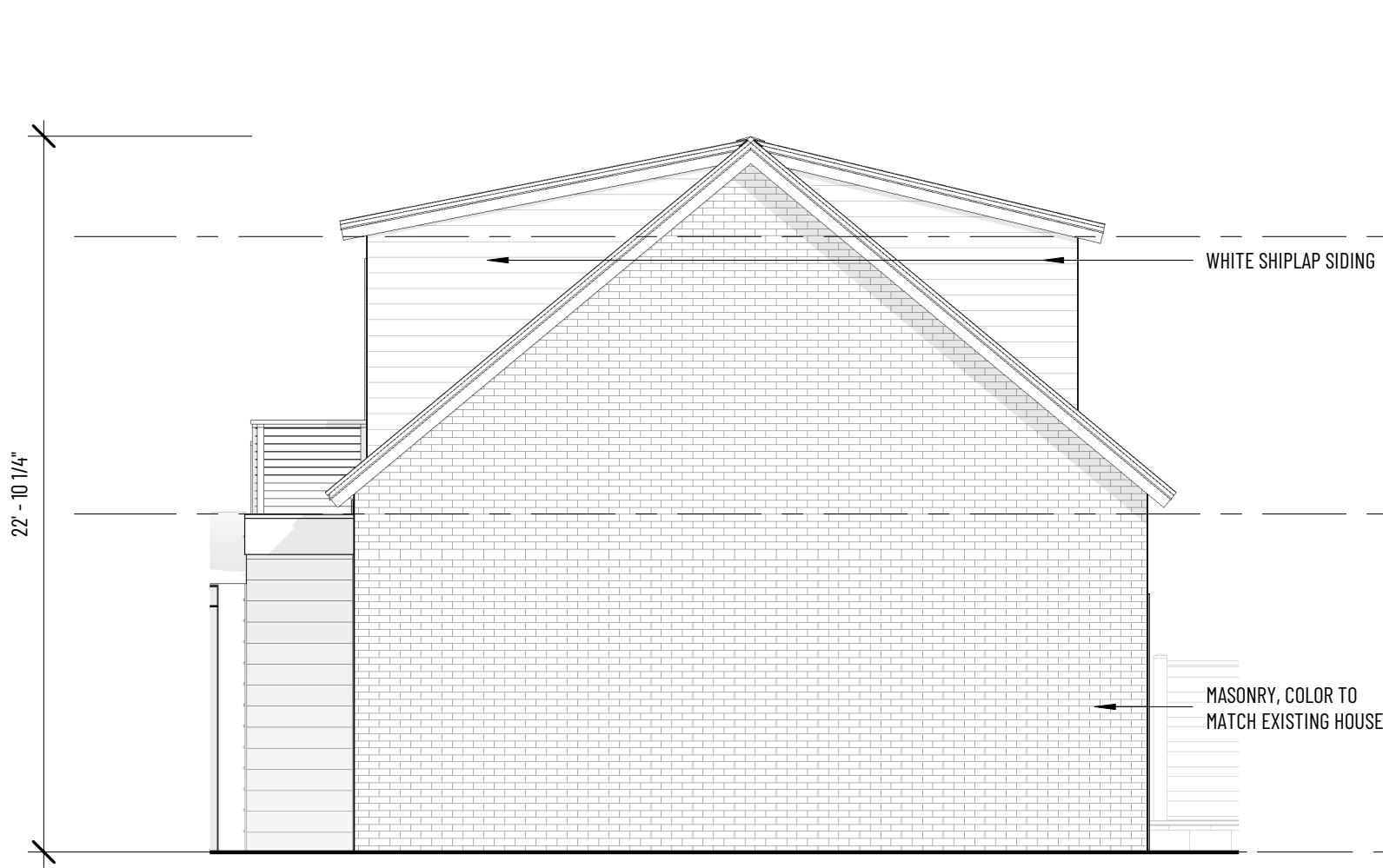

**1** Elev - Garage - Left

3/16" = 1'-0"

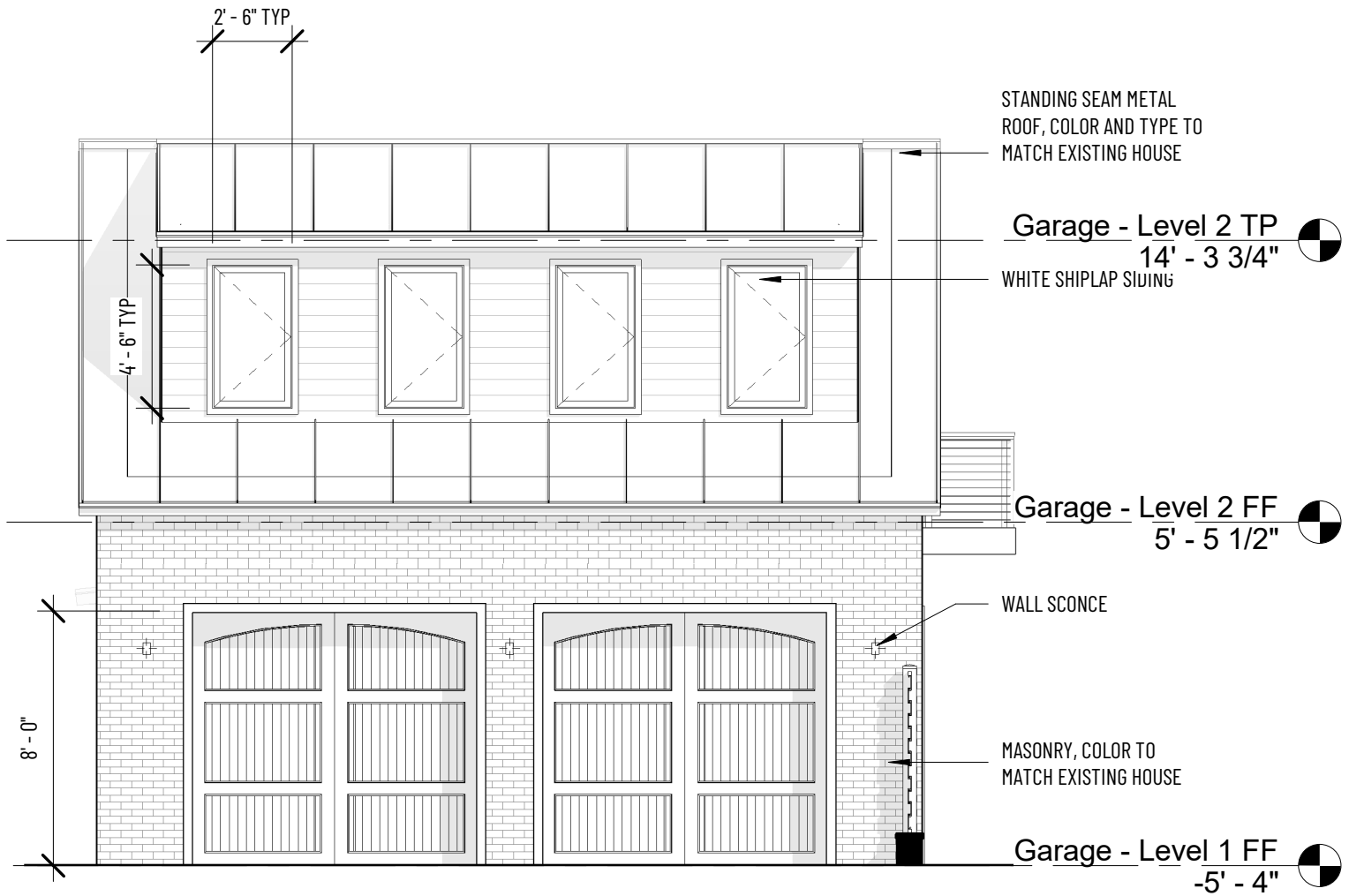

**2** Elev - Garage - Front

3/16" = 1'-0"



854 LOCUST AVE - Elevations

Scale: 3/16" = 1'-0"  
6/17/2021 4:32:39 PM



**1** Elev - Garage - Right

3/16" = 1'-0"

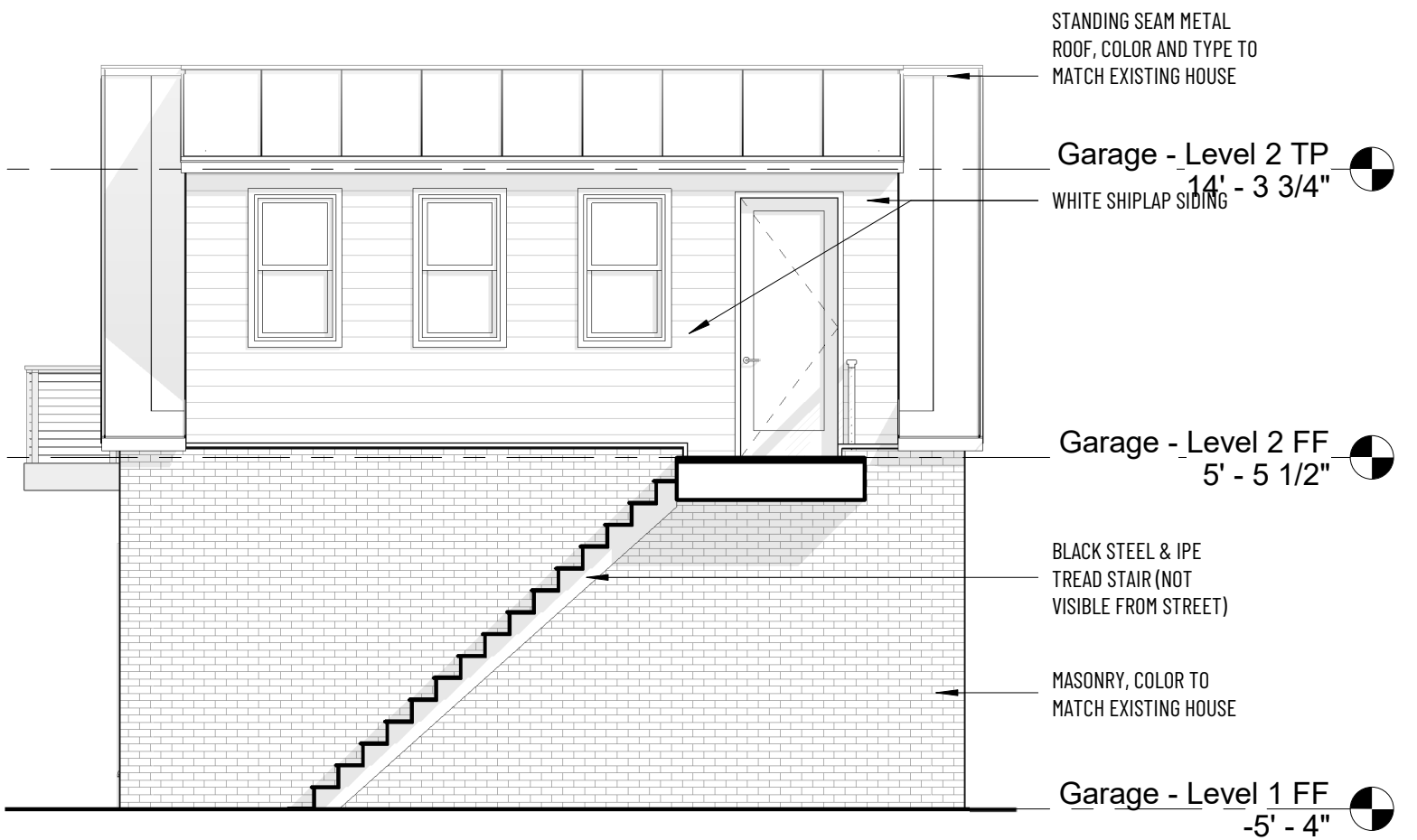

**2** Elev - Garage - Rear

3/16" = 1'-0"



BRACEY  
DESIGNS

854 LOCUST AVE - Elevations

Scale: 3/16" = 1'-0"  
6/17/2021 4:32:41 PM





EXISTING HOUSE



## 854 LOCUST AVE - Renderings

Scale: 1/2" = 1'-0"  
6/17/2021 4:32:41 PM

**Certificate of Appropriateness**

BAR 21-07-02

734 Locust Avenue, Tax Parcel 510073000

Martha Jefferson Historic Conservation District

Owner: Kathleen D. Free

Applicant: Barbara Gehrung

Project: Carriage house alterations

Application components (please click each link to go directly to PDF page):

- [Staff Report](#)
- [Historic Survey](#)
- [Application Submittal](#)

**City of Charlottesville  
Board of Architectural Review  
Staff Report  
July 20, 2021**



**Certificate of Appropriateness Application  
Historic Conservation District**

BAR 21-07-02  
734 Locust Avenue, Tax Parcel 510073000  
Martha Jefferson Historic Conservation District  
Owner: Kathleen D. Free  
Applicant: Barbara Gehrung  
Project: Carriage house alterations

---



**Background**

House:		Stable/Garage:	
Year Built:	c1901	Year Built:	c1901
District:	Martha Jefferson HC District	District:	Martha Jefferson HC District
Status:	Contributing	Status:	Contributing

The Eddins-Tilden House represents a Victorian Gothic-cottage style popular in the late 19<sup>th</sup> century. The brick stable/garage is similar in materiality and scale, but reflects a vernacular, use-oriented design. S.A. Eddins acquired the parcel in 1901, with no structures reported. In 1902, the sale of the property to B.R. Lester referred to the buildings on the site. Tax records also suggest the house and stable/garage were constructed at the time. (Curiously, Eddins owned the house only briefly and the City's historic survey does not explain the Tilden name associated with it.)

**Prior BAR Review**

December 2019 - Exterior modifications and rehabilitation. Administratively approved. (See appendix.)

**Application**

- Applicant Submitted: Gehrung + Graham, LLC et al drawings *734 Locust Ave Carriage House Renovation*:
  - Dated July 7, 2021: Sheets A0.1, A0.2, A1.0, A2.2, A2.3, and A2.4,
  - Dated July 16, 2021: Sheet A4.0.

Request for CoA to complete alterations to the former stable/garage.

North Elevation:

- Remove contemporary garage door; install entry door with side-lites.
- Remove plywood at upper opening; install wood casement windows.
- Repair masonry as needed.

West Elevation

- Remove contemporary windows, doors, and plywood; install wood casement windows, entry door, and twin French doors.
- Repair masonry as needed.

South Elevation

- Remove lower, double-hung window; install entry door.
- Repair or remove and replace (with new) the upper double-hung window.
- Repair masonry as needed.

East Elevation

- Repair existing windows.
- Repair masonry as needed.

### **Discussion**

Note: The regulations and guidelines for projects within a Historic Conservation District (HCD) are, by design, less rigid than those for an ADC District or an IPP. The HCD designations are intended to preserve the character-defining elements of the neighborhoods and to assure that new construction is not inappropriate to that character, while minimally imposing on current residents who may want to upgrade their homes. Within the existing HCDs are buildings and/or areas that might easily qualify for an ADC District or as an IPP; however, in evaluating proposals within HCDs, the BAR may apply only the HCD requirements and guidelines.

Within an HCD, the design review prioritizes what is visible from the public right of way. New structures concealed by the principal structure from all abutting streets are exempt from BAR review. With that, the four sides of the proposed garage are of the same design and materials, staff will focus on the front elevation.

This is an existing structure that the physical evidence suggests was constructed at one time. While the openings have been altered over time, the form, footprint, and materials (brick, metal roof) appear to be unchanged. If the c1901 date is correct, this was most likely built as a stable. (Even a decade later, automobile ownership remained extremely, locally and Virginia.<sup>1</sup>) Per the 1920 Sanborn Maps—see the Appendix—it can be assumed that between its construction and 1920, the stable was modified to accommodate an automobile garage at the north end. While there are visible alterations to the west elevation (also evident from the 1970s photos), we do not know when or in what sequence these occurred.

---

<sup>1</sup> “By 1910, Virginians owned 2,705 motor vehicles.” <https://www.virginiadot.org/about/resources/historyofrds.pdf> and “J.P. ‘Dry Goods’ Ellington purchased the first automobile in Albemarle County in 1906, triggering the automobile craze. With his purchase, Ellington became the proud owner of number 494 of the first 500 automobiles in Virginia.” <https://www.charlottesville.gov/673/History>

This proposal retains and extends the life of a historic structure. The proposed alterations do not significantly alter the building's character or materiality; in fact, they will rehabilitate and extend the life of this historic structure. Staff recommends approval.

### **Suggested Motion**

*Approval:* Having considered the standards set forth within the City Code, including the HC District Design Guidelines, I move to find that the alterations to and rehabilitation of the stable/garage at 734 Locust Avenue satisfy the BAR's criteria and are compatible with this property and other properties in the Martha Jefferson Historic Conservation District, and that the BAR approves the application as submitted.

### **Criteria, Standards, and Guidelines**

#### **Review Criteria Generally**

Sec. 34-341 of the City Code. Criteria for approval

- a) In considering a particular application the BAR shall approve the application unless it finds:
  - 1) That the proposal does not meet specific standards set forth within this division or applicable provisions of the conservation district design guidelines; and
  - 2) The proposal is incompatible with the historic, cultural or architectural character of the conservation district in which the property is located.
- b) The BAR's review of the proposed new construction or addition to a building or structure shall be limited to factors specified in section 34-342. The BAR's review of the proposed demolition, razing or moving of any contributing structure shall be limited to the factors specified in section 34-343.
- c) The BAR, or city council on appeal, may require conditions of approval as are necessary or desirable to ensure that any new construction or addition would be compatible with the scale and character of the historic conservation district. Prior to attaching conditions to an approval, due consideration shall be given to the cost of compliance with the proposed conditions.

Sec. 34-342 of the City Code. Standards for review of new construction and additions.

The following features and factors shall be considered in determining the appropriateness of proposed new construction and additions to buildings or structures:

- 1) Whether the form, height, scale, mass and placement of the proposed construction are visually and architecturally compatible with the site and the applicable conservation district;
- 2) The harmony of the proposed changes in terms of overall proportion and the size and placement of entrances and windows;
- 3) The impact of the proposed change on the essential architectural form and integrity of the existing building;
- 4) The effect, with respect to architectural considerations, of the proposed change on the conservation district neighborhood;
- 5) Any applicable provisions of the city's conservation district design guidelines.

#### **Pertinent Guidelines for the Martha Jefferson Historic Conservation District**

Architectural character-defining features:

1. Encourage one-story front porches;
2. Encourage garages to be located in the rear yards;

3. The levels of a building's stories should be consistent with those on surrounding structures with respect to the natural grade [for example, a first floor should not be raised so that it is higher than most surrounding first floors];
4. Do not exclude well-designed, new contemporary architecture [there may be a misconception that only historic-looking new buildings are permitted];
5. Encourage standing seam metal roofs;
6. Maintain and encourage tree canopy [Maintain the existing tree canopy and encourage new large shade trees];
7. The following Historic Conservation Overlay District Design Guidelines are especially pertinent:
  - a. maintain neighborhood massing and form;
  - b. encourage the use of sustainable materials; and
  - c. limit the height of fences in front yards to 3 ½ feet in height.
8. Regarding the future development of the hospital properties, the neighborhood's focus has been:
  - a. Not to tear down the old houses; to encourage low density residential development north of Taylor Walk (with the suggestion that Taylor Street be reinstated); and
  - b. to expect the High Street area to develop as a sensitively designed, high-quality, mixed use development;
9. Encourage good stewardship of Maplewood Cemetery.

**Appendix**

December 2019, Admin Approval: Exterior repairs, including repointing crumbling brick, repainting trim, selective repair/replacement of decaying porch flooring, replacing windows in existing openings, and possibly uncovering covered-up rafter tails. All other work will be interior. After review of the project scope and drawings, *staff grants administrative approval* for the proposed project, with the following recommendations:

1. Staff recommends adherence to the pertinent Design Guidelines for Rehabilitation regarding masonry:
  - a. When repointing masonry, duplicate mortar strength, composition, color, and texture.
  - b. Repoint to match original joints and retain the original joint width.
2. Staff recommends new windows have similar light configurations and muntins of similar dimensions to the existing windows.

1920 Sanborn Map and Current Aerial Photo

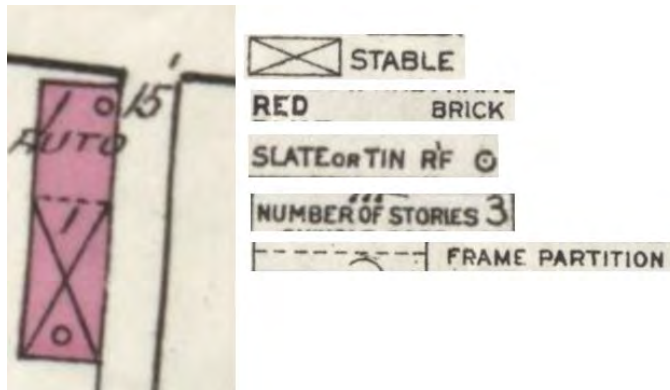
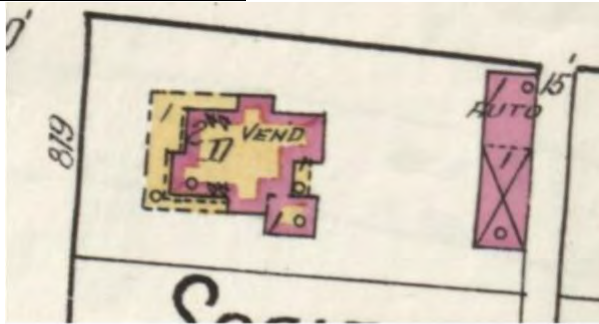

# LANDMARK



# SURVEY

Thompson Fall 1977

## IDENTIFICATION

Street Address: 734 Locust Avenue  
Map and Parcel: 51-73  
Census Track & Block: 3-307  
Present Owner: Ruth B. Davis  
Address: 734 Locust Avenue, City  
Present Use: Residence, Single-family  
Original Owner: S.A. Eddins  
Original Use: Residence

## BASE DATA

Historic Name: Eddins-Tilden House  
Date/Period: 1901  
Style: Victorian  
Height to Cornice:  
Height in Stories: 1½  
Present Zoning: R-2  
Land Area (sq.ft.): 13,125  
Assessed Value (land + imp.): 34,100

## ARCHITECTURAL DESCRIPTION

The Eddins-Tilden House is a typical example of the Victorian Gothic-cottage style as popularized by A.J. Downing in the late nineteenth century. Elements such as the gabled extensions, overhanging eaves with shaped rafter-ends, and turned pendules decorating the gable overhang, are all derivative from the Downingsque style, as is the veranda or porch that wraps around one corner of the house. Basic form of the house is that of a near square with four projecting ells - one to the right side of the facade, one each to the rear of either side, and a large kitchen wing on the rear diagonally opposite the facade extension. The main block is covered with a steep-pitch hip roof (with very short ridge), while extension roofs are gabled, with one plane of gable being an extension of a plane of the main hip slopes. The roof was originally covered with slate, which was replaced with the existing tin by the present owner's father. A later, single-storey bedroom addition abuts the rear next to the kitchen and is covered with a nearly-flat, shed roof. The house has three exterior, gable-end chimneys, one each in the side and rear ells, with a fourth interior side chimney on the Hazel Street side. Construction is brick with American bond. Building height is 1½ storeys with both dormer and gable-end windows lighting the upstairs. Main floor windows are one-over-one-light sash type with segmental-arch lintels. A single-storey veranda or porch stretches across the Locust Avenue facade and along the Hazel Street side to terminate against the gabled extension there. Square posts with chamfered corners support the porch roof.

## HISTORICAL DESCRIPTION

When the Locust Grove Investment Company subdivided the Locust Grove property (Plat Co. DB 107-266), Judge John M. White bought not only the main house with some 14 acres, but also in 1895 lots 9 and 10 (Co. DB 104-93). In 1901, White sold the two lots to S.A. Eddins (Co. DB 121-113) who paid \$900 for the lots and then borrowed an additional \$1600 to help finance the house he was building (Co. DB 121-116). A small rectangular stables/carriage house, behind the residence and opening onto Hazel Street, was probably built also at this time, as tax records show no buildings on the site prior to 1901. The next year, August 1902, Eddins sold the house and lot to B.R. Lester (Co. DB 124-17). After an additional transfer (Co. DB 129-100), ownership passed to Nannie T. Tilmans (Co. DB 138-169), who with the exception of a six-year period (1928-34) owned the house until 1946. At that time, the present owner's father, Walker L. Bunch purchased the property from the Tilmans (City DB 125-350). Mrs. Ruth B. Davis inherited the property upon the death of her father in 1964 (City WB 10-168). See also: Co. DB 107-266; City DB 60-388, 83-125, WB 8-8.

## GRAPHICS

## CONDITIONS

Good

## SOURCES

City and County Records







**Board of Architectural Review (BAR)  
Conservation District - Certificate of Appropriateness**

Please Return To: City of Charlottesville  
Department of Neighborhood Development Services  
P.O. Box 911, City Hall  
Charlottesville, Virginia 22902  
Telephone (434) 970-3130

Please submit ten (10) hard copies and one (1) digital copy of application form and all attachments.

Please include application fee as follows: New construction project \$375; Demolition of a contributing structure \$375; Appeal of BAR decision regarding new construction or demolition \$125. Make checks payable to the City of Charlottesville.

No fee required for: Additions and other projects requiring BAR approval and not listed above; Administrative approvals; Appeals of BAR decisions if the original application was not subject to an application fee.

The BAR meets the third Tuesday of the month.

Deadline for submittals is Tuesday 3 weeks prior to next BAR meeting by 3:30 p.m.

Project Name/Description CARRIAGEHOUSE RENOVATION Parcel Number 510073000  
Project Address/Location 734 LOCUST AVENUE, CHARLOTTESVILLE, VA 22902  
Owner Name KATHLEEN FREE Applicant Name BARBARA GEHRUNG

**Applicant Information** BAR

Address: 2055 FOAL LANE  
CHARLOTTESVILLE, VA 22901  
Email: BARBARA@GGEPA.US  
Phone: (W) 434 262 2392 (H) \_\_\_\_\_

**Signature of Applicant**

I hereby attest that the information I have provided is, to the best of my knowledge, correct

B. Gehrung 7/6/2021  
Signature Date

BARBARA GEHRUNG 7/6/2021  
Print Name Date

**Property Owner Information (if not applicant)**

KATHLEEN FREE  
Address: 734 LOCUST AVENUE  
CHARLOTTESVILLE, VA 22902  
Email: kdfree@comcast.net  
Phone: (W) 434 295-5758 (H) CELL - 434 989 4301

**Property Owner Permission (if not applicant)**

I have read this application and hereby give my consent to its submission.

Kathleen Free 7-6-2021  
Signature Date

KATHLEEN FREE 7-6-2021  
Print Name Date

Description of Proposed Work (attach separate narrative if necessary):

REMODEL + RENOVATION OF CARRIAGE HOUSE

List All Attachments (see reverse side for submittal requirements):

PDF DOCUMENT - DRAFT DRAWINGS -  
COMPLETE SET TO BE SUBMITTED 7/16/2021

**For Office Use Only**

Received by: \_\_\_\_\_

Fee paid: \_\_\_\_\_ Cash/Ck. # \_\_\_\_\_

Date Received: \_\_\_\_\_

Approved/Disapproved by: \_\_\_\_\_

Date: \_\_\_\_\_

Conditions of approval: \_\_\_\_\_



734 LOCUST AVE, CIRCA 1950



CARRIAGE HOUSE, CIRCA 1950

**PROJECT DESCRIPTION**

THE PROPERTY AT 734 LOCUST AVE IS LISTED AS A CONTRIBUTING STRUCTURE TO THE MARTHA JEFFERSON HISTORIC DISTRICT, HOWEVER, NEITHER MAIN RESIDENCE NOR CARRIAGE HOUSE ARE INDIVIDUALLY PROTECTED.

THE CURRENT OWNER, DR. KATHLEE FREE, PURCHASED THE PROPERTY IN 2019 AND RENOVATED THE MAIN HOUSE IN 2020. IT IS HER PRIMARY RESIDENCE.

THE CARRIAGE HOUSE AT 734 LOCUST NEEDS URGENT STRUCTURAL REPAIR AND MAINTENANCE, AFTER YEARS OF NEGLECT. THE OWNER PLANS TO RESTORE THE EXTERIOR OF THE BUILDING AND REMODEL A PORTION OF THE INTERIOR INTO AN ACCESSORY DWELLING UNIT. THE OWNER'S BUILDER AN ARCHITECT WILL SUBMIT A BUILDING PERMIT APPLICATION TO THE CITY OF CHARLOTTEVILLE, ONCE THE BOARD OF ARCHITECTURAL REVIEW APPROVES THE DESIGN FOR THE RENOVATION.

WITH THE RENOVATION THE OWNER AND DESIGN TEAM PLAN TO THOUGHTFULLY REPLACE THE NON-ORIGINAL AND LOW-QUALITY ELEMENTS, AND PRESERVE & ENHANCE THE STRUCTURAL INTEGRITY OF THE BUILDING. ITEMS TO BE REPLACED INCLUDE VINYL WINDOWS, THE VINYL GARAGE DOOR, UTILITY DOORS MADE FROM T1-11 SIDING, AND BROKEN AND NON-ORIGINAL FAÇADE MATERIALS.

IN ADDITION TO HAVING RECENTLY RENOVATED THE MAIN HOUSE AT 734 LOCUST AVE, THE OWNER HAS PREVIOUSLY RENOVATED SEVERAL RESIDENTIAL PROPERTIES WITHIN THE CITY OF CHARLOTTEVILLE. KATHLEEN STRIVES TO PRESERVE AND ELEVATE THE HISTORY OF A BUILDING AND TO INTEGRATE SALVAGED AND ORIGINAL ARCHITECTURAL COMPONENTS, SUCH AS HISTORIC WINDOWS AND DOORS AND RECLAIMED HARDWARE. FOR THIS PROJECT SHE HAS ALREADY PROCURED MATCHING HANDMADE BRICKS AND HISTORIC WINDOWS AND DOORS WHICH ARE IN KEEPING WITH THE PERIOD OF THE ORIGINAL CONSTRUCTION, AND THE CONTEXTUAL SCALE OF THE CARRIAGE HOUSE AND MAIN RESIDENCE.

ALREADY PROCURED MATCHING HANDMADE BRICKS AND HISTORIC WINDOWS AND DOORS WHICH ARE IN KEEPING WITH THE PERIOD OF THE ORIGINAL CONSTRUCTION, AND THE CONTEXTUAL SCALE OF THE CARRIAGE HOUSE AND MAIN RESIDENCE.

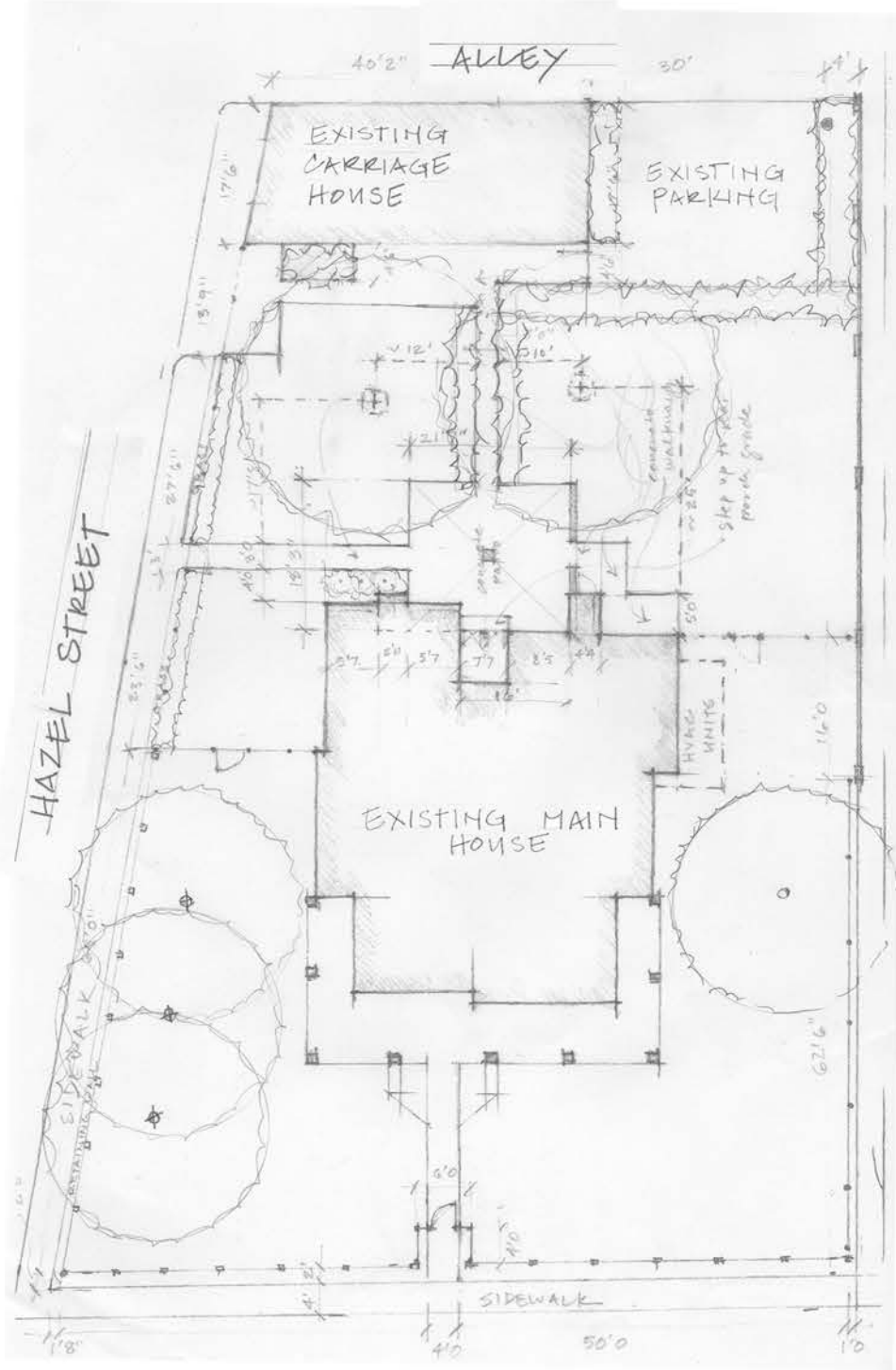

SITE PLAN CONTEXT

SHEET	NUMBER	TITLE	INCLUDED BAR APPLICATION 7/7/21	TO BE ADDED TO BAR SUBMISSION 7/16/21	TO BE ADDED TO BUILDING PERMIT APPLICATION	REVISION DATE
A	0.1	COVER SHEET	X			7/16/2021
A	0.2	PAST-PRESENT-FUTURE	X			
A	0.3	SITE CONTEXT		X		
A	0.4	SITE PLAN			X	
A	1.0	EXISTING EXTERIOR CONDITIONS	X			
A	1.1	AS-BUILT FLOOR PLAN FIRST FLOOR			X	
A	1.2	AS-BUILT FLOOR PLAN ATTIC			X	
A	2.0	FLOOR PLAN FIRST FLOOR REMODEL			X	
A	2.1	FLOOR PLAN ATTIC REMODEL			X	
A	2.2	BEFORE-AFTER YARD ELEVATION	X			
A	2.3	YARD (WEST) ELEVATION REMODEL		X		7/16/2021
A	2.4	BEFORE-AFTER NORTH ELEVATION	X			7/16/2021
A	2.5	BEFORE-AFTER SOUTH ELEVATION		X		7/16/2021
A	2.6	GABLE (NORTH & SOUTH) ELEVATIONS REMODEL		X		7/16/2021
A	2.7	ALLEY (NORTH) ELEVATION	X			7/16/2021
A	3.0	SECTIONS			X	
A	3.1	SECTIONS			X	
A	3.2	PERSPECTIVE SECTIONS			X	
A	4.0	WINDOW & DOOR SCHEDULE			X	
S	TBD	STRUCTURAL			X	

GENERAL CONTRACTOR  
  
**BONCRAFT BUILDERS LLC**  
 705 GRAVES STREET  
 CHARLOTTEVILLE, VA 22902  
 434-987-2549

ARCHITECT  
  
**GEHRUNG + GRAHAM LLC**  
 energy positive architecture  
 2055 Foal Lane, Charlottesville, VA 22901 | www.gehrunggraham.com  
 PHONE: 434-292-2392 EMAIL: torborra@gppa.us

STRUCTURAL ENGINEER  
  
**CURRY & ASSOCIATES**  
 120 RIVERBLUFF CIRCLE  
 CHARLOTTEVILLE, VA 22902  
 434-361-0180  
 info@curryandassociates.com

OWNER  
  
**DR. KATHLEEN FREE**  
 734 LOCUST AVE,  
 CHARLOTTEVILLE, VA 22902

PROJECT MANAGER Barbara Gehring barbara@gehrung.com 434-292-2392	DRAWN BY bg	REVIEWED BY CCKK	PAPER SIZE & SCALE REFERENCE to be printed on 11x17
First Submission Date 7/7/2021	Project ID 1917	File Path C:\Users\barbara\Documents\734 Locust Ave\734 Locust Ave.dwg	
Revision 1 Date 7/16/2021	Revision 2 Date		

7/16/2021 BAR REVIEW SET REV1: additional pages, see index on cover page A0.1, updated numbering, updated text.

PROJECT TITLE  
  
**734 LOCUST AVE,  
 CHARLOTTEVILLE  
 CARRIAGE HOUSE  
 RENOVATION**

SET NAME  
  
**BAR REVIEW SET**

SHEET TITLE  
  
**COVER SHEET**

SHEET NUMBER  
  
**A 0.1**

**HISTORY**



ACCORDING TO THE HISTORIC SURVEY FROM 1977, THE CARRIAGE HOUSE IN THE REAR OF 734 LOCUST AVENUE WAS LIKELY BUILT AROUND THE SAME TIME AS THE MAIN HOUSE, AFTER 1901.

IN THE PAST IT HAS BEEN USED AS HORSE STABLE AND BARN. A STOVE PIPE HOLE AND RESIDUAL PLASTER IN THE RIGHT HALF OF THE GROUND FLOOR POINT TOWARDS PREVIOUS USE AS SLEEPING QUARTERS.

THE FACADE TOWARDS THE YARD AND LOCUST AVENUE HAD MULTIPLE DOORS AND WINDOWS, PROBABLY TO ACCESS THE HORSE BOXES INSIDE, THE RIGHT PORTION FEATURES A LARGE BRICK OPENING WITH A DOOR FOR A CARRIAGE. THE GABLE END TOWARDS HAZEL ST HAD TWO LARGE DOORS ON THE GROUND LEVEL, AND A HATCH DOOR TO ACCESS THE BARN ATTIC. THE GABLE IS CLAD IN METAL PANELS, WHICH APPEAR IDENTICAL TO THE EXISTING.

THERE IS NO DOCUMENTATION OF THE ORIGINAL CONDITION OF THE REAR GABLE END AND THE FACADE TOWARDS THE ALLEY, HOWEVER, THE EXISTING OPENINGS APPEAR TO BE ORIGINAL.

**PRESENT**



CURRENTLY THE BUILDING IS USED AS GARAGE AND FOR STORAGE.

THE GROUND LEVEL HAS A VINYL ROLL-UP GARAGE DOOR, WHICH WAS PROBABLY INSTALLED IN THE PAST 20 YEARS. THE HEADER ABOVE SHOWS STRONG DEFLECTION AS IT CONSISTS OF STACKED 2Xs. SIMILARLY, THE STRUCTURE AT THE LARGE BRICK OPENING IN THE MAIN FACADE NEEDS TO BE RETROFITTED AND REPAIRED. WINDOWS AND DOORS APPEAR TO HAVE BEEN RANDOMLY REPLACED, OPENINGS BRICKED-UP AND ALTERED. THE OUTLINE OF PREVIOUS OPENINGS ARE VISIBLE IN THE BRICK WALLS.

**FUTURE**



AFTER THE RENOVATIONS WILL BE APPROVED AND COMPLETED, THE CARRIAGE HOUSE WILL PARTIALLY SERVE AS ACCESSORY DWELLING UNIT.

**EXTERIOR ELEMENTS TO BE REPAIRED AND REMODELED:**  
REPAIR, REPOINT ALL BRICK, INSERT STRUCTURAL HEADERS AND LINTELS AS NEEDED. REPAINT ALL PAINTED WOOD. PAINT COLOR TBD.

**YARD FACADE:**

- REPAIR AND REBUILD BRICK AT OPENING, INSERT STRUCTURAL HEADER, STRAIGHTEN AND LIFT ROOF.
- REPLACE VINYL WINDOWS IN YARD FACADE WITH RESTORED, ANTIQUE WOOD CASEMENTS
- REPLACE SLAB DOOR WITH GLAZED PANEL DOOR
- REPLACE T1-11 SIDING AND DOORS WITH BOARD-AND-BATTEN SIDING, ANTIQUE CASEMENT WINDOWS AND FRENCH DOORS

**HAZEL STREET FACADE**

- REPAIR AND REBUILD BRICK WALL, OPENING, INSERT STRUCTURAL FOOTINGS AND HEADERS, WIDTH TO BE REDUCED)
- REPLACE GARAGE ROLL-GATE WITH paneled and glazed ENTRY DOOR WITH VENTING SIDELIGHTS
- REPLACE BARN DOOR HATCH WITH DOUBLE CASEMENT WINDOWS. OPENING TO BE EXPANDED VERTICALLY.

**SIDE YARD FACADE**

- REPLACE 1ST FLOOR WINDOW WITH ENTRY DOOR
- REPAIR EXISTING DOUBLE HUNG WINDOW ON 2ND FLOOR OR REPLACE WITH NEW WOOD-ALUMINUM CLAD WINDOW

**ALLEY FACADE:**

- RESTORE EXISTING WINDOWS AND SCREENS

GENERAL CONTRACTOR			
<b>BONCRAFT BUILDERS LLC</b> 705 GRAVES STREET CHARLOTTESVILLE, VA 22902 434-987-2549			
ARCHITECT			
<b>GEHRUNG + GRAHAM LLC</b> energy positive architecture <small>3035 Falls Lane, Charlottesville, VA 22901   www.gehrunggraham.com</small> <small>PHONE: 434.987.0180   info@gehrunggraham.com</small>			
STRUCTURAL ENGINEER			
<b>CURRY &amp; ASSOCIATES</b> 120 RIVERBLUFF CIRCLE CHARLOTTESVILLE, VA 22902 434-361-0180 info@curryandassociates.com			
OWNER			
<b>DR. KATHLEEN FREE</b> 734 LOCUST AVE, CHARLOTTESVILLE, VA 22902			
PROJECT MANAGER	DRAWN BY	REVIEWED BY	PAPER SIZE & SCALE REFERENCE
Rebecca Galloway rebecca@gehrunggraham.com	bg	CLK	to be printed on 11x17
Final Submission Date	Project ID	Revision	File Path
7/7/2021	1917		C:\Users\bgalloway\Documents\734 Locust Ave Carriage House\734 Locust Ave Carriage House.dwg
Revision 1 Date	Revision 2 Date		
7/16/2021			
7/16/2021	BAR REVIEW SET	REV1: additional pages, see index on cover page A0.1, updated numbering, updated text.	
PROJECT FILE			
<b>734 LOCUST AVE,          CHARLOTTESVILLE          CARRIAGE HOUSE          RENOVATION</b>			
SET NAME			
<b>BAR REVIEW SET</b>			
SHEET TITLE			
<b>PROJECT DESCRIPTION          PAST-PRESENT-FUTURE</b>			
SHEET NUMBER			
<b>A 0.2</b>			



734 LOCUST AVE: PHOTOGRAPH FROM THE 1950s  
(SOURCE HISTORIC SURVEY)



FRONT PRE-RENOVATION  
(SOURCE GOOGLE)



FRONT POST RENOVATION, SUMMER 2021  
(SOURCE: G+G)



VIEW FROM HAZEL ST PHOTOGRAPH FROM THE 1950s  
(SOURCE HISTORIC SURVEY)



REAR POST RENOVATION, VIEW FROM HAZEL STREET  
(SOURCE: G+G)



REAR POST RENOVATION, VIEW FROM CARRIAGE HOUSE  
(SOURCE: G+G)



VIEW FROM LOCUST AVE TO CARRIAGE HOUSE  
(SOURCE G+G)



VIEW FROM ALLEY TO HOUSE & CARRIAGE HOUSE  
(SOURCE G+G)



VIEW FROM MAIN HOUSE EAST PORCH TO CARRIAGE HOUSE  
(SOURCE G+G)

GENERAL CONTRACTOR  
**BONCRAFT BUILDERS LLC**  
705 GRAVES STREET  
CHARLOTTESVILLE, VA 22902  
434-987-2549

ARCHITECT  
**GEHRUNG + GRAHAM LLC**  
energy positive architecture  
2055 Fox Lane, Charlottesville, VA 22901 | www.gehrunggraham.com  
PHONE: 434-257-7330 ext. 101 | barbara@ggps.us

STRUCTURAL ENGINEER  
**CURRY & ASSOCIATES**  
120 RIVERBLUFF CIRCLE  
CHARLOTTESVILLE, VA 22902  
434-361-0180  
info@curryandassociates.com

OWNER  
**DR. KATHLEEN FREE**  
734 LOCUST AVE,  
CHARLOTTESVILLE, VA 22902

PROJECT MANAGER Barbara Gehring barbara@ggps.us 434-257-7330	DRAWN BY bg	REVIEWED BY MG	PAPER SIZE & SCALE REFERENCE to be printed on 11x17
First Submission Date 7/7/2021	Project ID 1917	File Path C:\Users\kfree\Documents\734 Locust Ave\734 Locust Ave - BAR REVIEW SET.rvt	
Revision 1 Date 7/16/2021	Revision 2 Date		

7/16/2021	BAR REVIEW SET	REV1: additional pages, see index on cover page A0.1, updated numbering, updated text
-----------	----------------	---

PROJECT TITLE  
**734 LOCUST AVE,  
CHARLOTTESVILLE  
CARRIAGE HOUSE  
RENOVATION**

SET NAME  
**BAR REVIEW SET**

SHEET TITLE  
**SITE CONTEXT**

SHEET NUMBER  
**A 0.3**

**EXISTING STRUCTURE**

EXTERIOR WALLS 1ST FLOOR: 2-WIDE CLAY BRICK WYTHE ,  
 ATTIC: WOOD FRAME OVER 2' BRICK KNEE WALLS  
 STEEL TIE AT SOUTH GABLE  
 T1-11 PLYWOOD PANEL SIDING (NOT ORIGINAL) AND  
 EMBOSSED METAL PANELING  
 FOUNDATION: NOT DOCUMENTED  
 ROOF: TRUE 2X4, 24" O.C.+/-, RAFTERS  
 ORIGINAL STANDING SEAM METAL ROOF, PAINTED,  
 PITCH 45DEG, EXPOSED RAFTER TAILS  
 DOORS: MIXED, NOT ORIGINAL  
 WINDOWS: RANDOM SIZES, MIXTURE OF ORIGINAL  
 AND VINYL REPLACEMENT WINDOWS  
 SLABS: CONCRETE ON GRADE AND CONCRETE ON  
 CLAY BRICK

**CONDITION OF BUILDING EXTERIOR:**

- BRICK STRUCTURE IN NEED OF REPAIR AND REPOINTING, DISLODGED BRICKS AT OPENINGS AND CORNERS,, STRUCTURAL REPAIRS NEEDED
- BROKEN OR INSUFFICIENT LINTELS OR JAMBS
- AUTOMATIC GARAGE DOOR TO HAZEL STREET HAS NO PROPER LINTEL OR HEADER
- EMBOSSED METAL FACADE PANELS AT GABLES IS HEAVILY CORRODED AND FALLING APART
- STANDING SEAM METAL ROOF IS IN GOOD CONDITION, WAS RECENTLY PAINTED BY NEW OWNER
- ROOF IS PARTIALLY BUCKLING BECAUSE OF INSUFFICIENT STRUCTURAL SUPPORT. NEEDS TO BE LOCALLY REINFORCED.

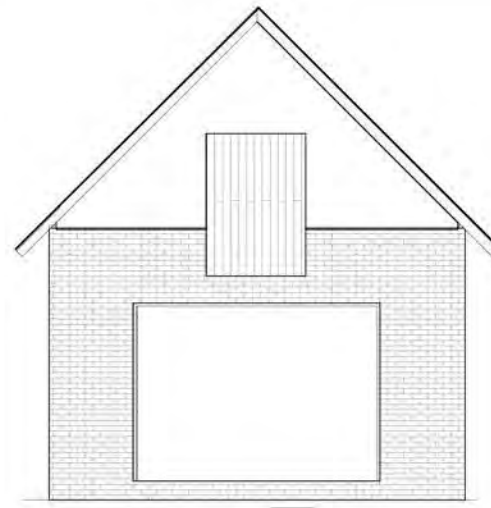

HAZEL ST (NORTH) ELEVATION



BACKYARD (WEST) ELEVATION

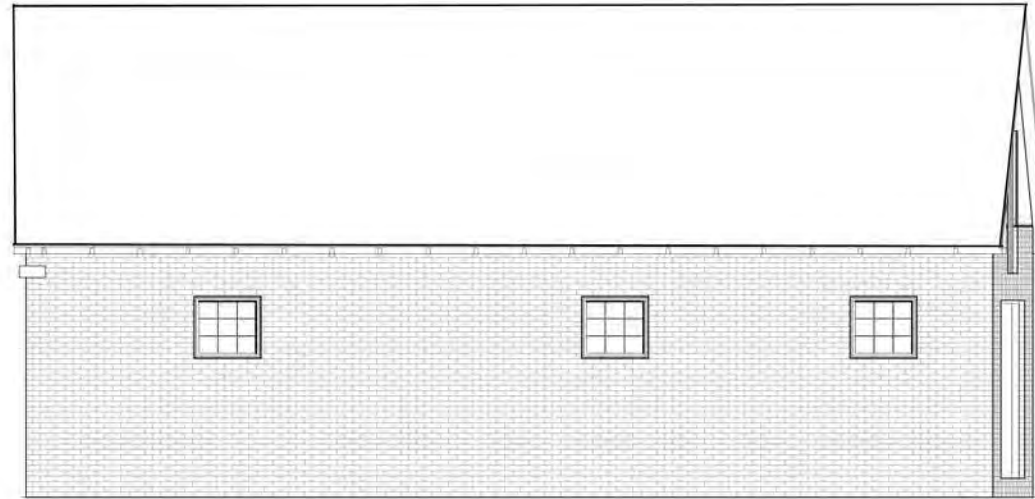

ALLEY (EAST) ELEVATION

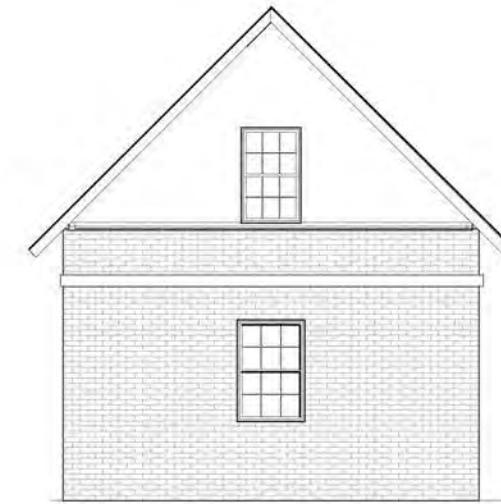

SIDE YARD (SOUTH) ELEVATION



HAZEL ST (NORTH) FACADE



BACKYARD & HAZEL ST FACADE



SIDE YARD AND ALLEY FACADE

GENERAL CONTRACTOR  
**BONCRAFT BUILDERS LLC**  
 705 GRAVES STREET  
 CHARLOTTESVILLE, VA 22902  
 434-987-2549

ARCHITECT  
**GEHRUNG + GRAHAM LLC**  
 energy positive architecture  
 2055 Fall Lane, Charlottesville, VA 22901 | www.gehrunggraham.com  
 PHONE: 434-292-0382 EMAIL: jgraham@gehrung.com

STRUCTURAL ENGINEER  
**CURRY & ASSOCIATES**  
 120 RIVERBLUFF CIRCLE  
 CHARLOTTESVILLE, VA 22902  
 434-361-0180  
 info@curryandassociates.com

OWNER  
**DR. KATHLEEN FREE**  
 734 LOCUST AVE,  
 CHARLOTTESVILLE, VA 22902

PROJECT MANAGER Barbara Calvey barcalvey@gehrung.com 434-292-0382	DRAWN BY bg	REVIEWED BY CCK	PAPER SIZE & SCALE REFERENCE to be printed on 11x17
First Submission Date 7/7/2021/2021	Project ID 1917	File Path C:\Users\jgraham\Documents\20210707_734 Locust Ave\20210707_734 Locust Ave.dwg	
Revision 1 Date 7/16/2021	Revision 2 Date		

7/16/2021	BAR REVIEW SET	REV1: additional pages, see index on cover page A0.1, updated numbering, updated text.
-----------	----------------	--

PROJECT TITLE  
**734 LOCUST AVE,  
 CHARLOTTESVILLE  
 CARRIAGE HOUSE  
 RENOVATION**

SET NAME  
**BAR REVIEW SET**

SHEET TITLE  
**EXISTING EXTERIOR  
 CONDITIONS**

SHEET NUMBER  
**A 1.0**

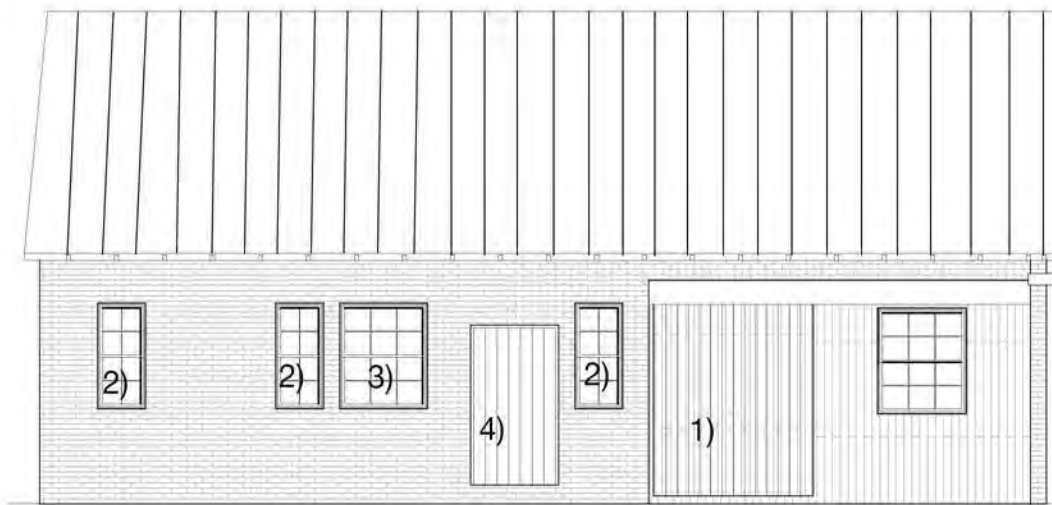

BACKYARD (WEST) ELEVATION, EXISTING

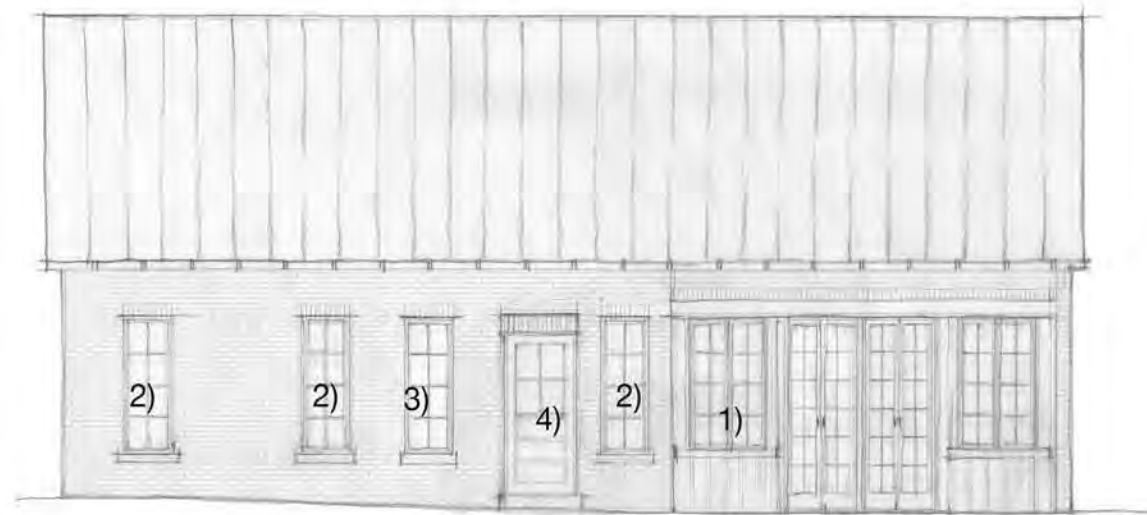

BACKYARD (WEST) ELEVATION, REMODEL

**WORK TO BE PERFORMED**

- 1) STRUCTURE OVER WOOD FRAMED EXTERIOR WALL NEEDS TO BE REINFORCED:
  - STEEL HEADER AND INTERIOR POSTS TO BE INSERTED
  - BRICK KNEE WALL TO BE PARTIALLY DEMOLISHED AND SUBSEQUENTLY REBUILT
  - T1-11 SIDING, DOORS AND VINYL WINDOW TO BE REPLACED WITH ANTIQUE, RESTORED CASEMENT WINDOWS & DOORS
- 2) EXISTING HISTORIC WINDOW OPENINGS TO BE REPAIRED
  - INSERT NEW LINTELS/HEADERS, AS NEEDED
  - RETAIN BRICK OPENING WIDTH
  - LOWER SILL HEIGHT
  - REPLACE VINYL WINDOWS WITH RESTORED ANTIQUE CASEMENT WINDOWS
  - REPAIR FALLEN-IN BRICK OPENINGS WITH SOLDIER COURSE, MATCHING TO EXISTING
- 3) REPLACE NON-HISTORIC WINDOW WITH ANTIQUE, RESTORED CASEMENT, IDENTICAL TO WINDOWS OUTLINED IN 2), OPENING SIZE TO BE REDUCED, FILLED IN WITH MATCHING ANTIQUE BRICKS
- 4) REPLACE EXISTING NON-HISTORIC DOOR WITH GLASS PANEL DOOR FOUND ON SITE.
  - OPENING WIDTH TO BE REDUCED. FILLED IN WITH MATCHING ANTIQUE BRICK

NEW WINDOWS TO BE PELLA ARCHITECT SERIES OR SIMILAR, WOOD OR WOOD-CLAD WITH TRUE OR SIMULATED DIVIDED LIGHTS WITH SPACERS..



DOOR 4)



CASEMENTS 1)



CASEMENTS 2) AND DOORS 1)

<p>GENERAL CONTRACTOR</p> <p><b>BONCRAFT BUILDERS LLC</b> 705 GRAVES STREET CHARLOTTESVILLE, VA 22902 434-987-2549</p>			
<p>ARCHITECT</p> <p><b>GEHRUNG + GRAHAM LLC</b> energy positive architecture 2055 Fox Lane, Charlottesville, VA 22901   www.gehrunggraham.com PH: 434-267-7252 ext. 101   btorres@ggrg.com</p>			
<p>STRUCTURAL ENGINEER</p> <p><b>CURRY &amp; ASSOCIATES</b> 120 RIVERBLUFF CIRCLE CHARLOTTESVILLE, VA 22902 434-361-0180 info@curryandassociates.com</p>			
<p>OWNER</p> <p><b>DR. KATHLEEN FREE</b> 734 LOCUST AVE, CHARLOTTESVILLE, VA 22902</p>			
<p>PROJECT MANAGER: Barbara Gehring barbara@gehrunggraham.com 434-267-2702</p>	<p>DRAWN BY: bg</p>	<p>REVIEWED BY: CCK</p>	<p>PAPER SIZE &amp; SCALE REFERENCE: to be printed on 11x17</p>
<p>First Submission Date: 7/7/2021</p>	<p>Project ID: 1917</p>	<p>File Path: C:\Projects\2021\734 Locust Ave\734 Locust Ave - Bar Review Set.dwg</p>	
<p>Revision 1 Date: 7/16/2021</p>	<p>Revision 2 Date:</p>	<p>REVT: additional pages, see index on cover page A0.1, updated numbering, updated text.</p>	
<p>7/16/2021</p>	<p>BAR REVIEW SET</p>		
<p>PROJECT TITLE</p> <p><b>734 LOCUST AVE, CHARLOTTESVILLE CARRIAGE HOUSE RENOVATION</b></p>			
<p>SET NAME</p> <p><b>BAR REVIEW SET</b></p>			
<p>SHEET TITLE</p> <p><b>BEFORE-AFTER YARD (WEST) ELEVATION</b></p>			
<p>SHEET NUMBER</p> <p><b>A 2.2</b></p>			

GENERAL CONTRACTOR

BONCRAFT BUILDERS LLC  
705 GRAVES STREET  
CHARLOTTESVILLE, VA 22902  
434-987-2549

ARCHITECT

GEHRUNG + GRAHAM LLC  
energy positive architecture  
2055 Foal Lane, Charlottesville, VA 22901 | www.gehrunggraham.com  
PHONE: 434-202-2392 EMAIL: barbara@gppa.us

STRUCTURAL ENGINEER

CURRY & ASSOCIATES  
120 RIVERBLUFF CIRCLE  
CHARLOTTESVILLE, VA 22902  
434-361-0180  
info@curryandassociates.com

OWNER

DR. KATHLEEN FREE  
734 LOCUST AVE,  
CHARLOTTESVILLE, VA 22902

PROJECT MANAGER Barbara Gehring barbara@gehrung.com 434-202-2392	DRAWN BY bg	REVIEWED BY CCK	PAPER SIZE & SCALE REFERENCE to be printed on 11x17
First Submission Date 7/7/2021	Project ID 1917	File Path C:\Users\barbara\Documents\734 Locust Ave\734 Locust Ave.dwg	
Revision 1 Date 7/16/2021	Revision 2 Date		

7/16/2021 BAR REVIEW SET REV1: additional pages, see index on cover page A0.1, updated numbering, updated text.

PROJECT TITLE

734 LOCUST AVE,  
CHARLOTTESVILLE  
CARRIAGE HOUSE  
RENOVATION

SET NAME

BAR REVIEW SET

SHEET TITLE

YARD ELEVATION  
REMODEL

SHEET NUMBER

A 2.3



YARD (WEST) ELEVATION PROPOSED  
SCALE: 1/4" = 1'-0"



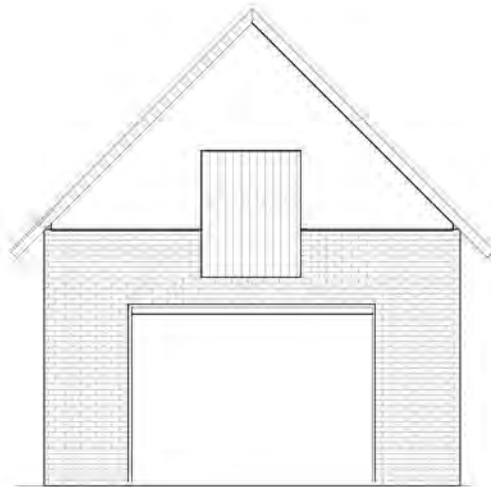

HAZEL STREET (NORTH) ELEVATION, EXISTING

HAZEL ST (NORTH)) ELEVATION, REMODEL

**WORK TO BE PERFORMED**

- 1) REMODEL DOOR OPENING TO HAZEL STREET
  - HEADER NOT STRUCTURALLY SOUND, NEW STRUCTURAL LINTEL TO BE INSERTED
  - BRICK WALL ABOVE NEEDS TO BE PARTIALLY DEMOLISHED AND REBUILT WITH RECLAIMED AND MATCHING ANTIQUE BRICKS
  - VINYL ROLLING GARAGE DOOR TO BE REPLACED WITH FRONT DOOR AND SIDELIGHTS
  - BRICK OPENING WIDTH TO BE REDUCED FROM 10' TO 4' (HISTORIC PHOTOGRAPHS SHOWS 2 DOORS WITH CENTER POST)
  - OPENING HEIGHT TO BE RETAINED
  
- 2) REPLACE HATCH DOOR WITH CASEMENT WINDOWS
  - OPENING WIDTH TO BE RETAINED, OPENING HEIGHT TO BE ENLARGED TO PROVIDE INCREASED DAYLIGHT IN ATTIC
  
- 3) CORRODED AND BROKEN STAMPED METAL SIDING TO BE REPLACED WITH BOARD AND BATTEN (WOOD OR FIBER-CEMENT) SIDING



PHOTOGRAPH JELD-WEN WOOD-CLADD FRONT DOOR

GENERAL CONTRACTOR  <b>BONCRAFT BUILDERS LLC</b> 705 GRAVES STREET CHARLOTTESVILLE, VA 22902 434-987-2549			
ARCHITECT  <b>GEHRUNG + GRAHAM LLC</b> energy positive architecture <small>2025 Fox Lane, Charlottesville, VA 22901   www.gehrunggraham.com</small> <small>PHONE: 434-285-0911   info@gehrung.com</small>			
STRUCTURAL ENGINEER  <b>CURRY &amp; ASSOCIATES</b> 120 RIVERBLUFF CIRCLE CHARLOTTESVILLE, VA 22902 434-361-0180 info@curryandassociates.com			
OWNER  <b>DR. KATHLEEN FREE</b> 734 LOCUST AVE, CHARLOTTESVILLE, VA 22902			
PROJECT MANAGER Barbara Culberg bculberg@gehrung.com 434-285-2392	DESIGNED BY DG	REVIEWED BY CCB	PAPER SIZE & SCALE REFERENCE to be printed on 11x17
First Submission Date 7/7/2021	Project ID 1917	File Path C:\Users\barbara\Documents\1917_Hazeltown_CarriageHouse\1917_Hazeltown_CarriageHouse.dwg 7/16/2021	
Revision 1 Date 7/16/2021	Revision 2 Date		
7/16/2021	BAR REVIEW SET	REV1: additional pages, see index on cover page A0.1, updated numbering, updated text.	
PROJECT TITLE  <b>734 LOCUST AVE,          CHARLOTTESVILLE          CARRIAGE HOUSE          RENOVATION</b>			
SHEET NAME  <b>BAR REVIEW SET</b>			
SHEET TITLE  <b>BEFORE AFTER          HAZEL ST ELEVATION</b>			
SHEET NUMBER  <b>A 2.4</b>			

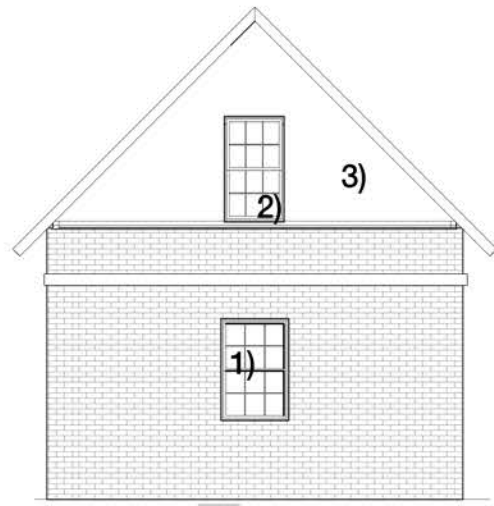

SIDE YARD (SOUTH) ELEVATION, EXISTING

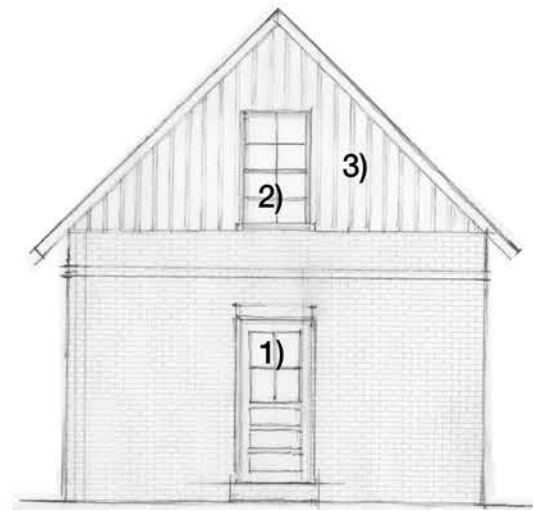

SIDE YARD (SOUTH) ELEVATION, REMODEL

- 1) REPLACE WINDOW ON GROUND FLOOR WITH DOOR (GLAZED PANEL DOOR OR SIMILAR)
  - HEADER, LINTEL AND BRICK OPENING TO BE REPAIRED
  - OPENING WIDTH TO BE RETAINED
- 2) RESTORE EXISTING 2ND FLOOR DOUBLE HUNG WINDOW, AS POSSIBLE, ALTERNATIVELY, REPLACE WITH WOOD OR WOOD-CLAD WINDOW IN KIND
- 3) BROKEN STAMPED METAL SIDING TO BE REPLACED WITH BOARD AND BATTEN WOOD OR FIBER-CEMENT SIDING

GENERAL CONTRACTOR

BONCRAFT BUILDERS LLC  
705 GRAVES STREET  
CHARLOTTESVILLE, VA 22902  
434-987-2549

ARCHITECT

GEHRUNG + GRAHAM LLC  
energy positive architecture  
2055 Foal Lane, Charlottesville, VA 22901 | www.gehrunggraham.com  
PHONE: 434-202-2392 EMAIL: barbara@ggpps.us

STRUCTURAL ENGINEER

CURRY & ASSOCIATES  
120 RIVERBLUFF CIRCLE  
CHARLOTTESVILLE, VA 22902  
434-361-0180  
info@curryandassociates.com

OWNER

DR. KATHLEEN FREE  
734 LOCUST AVE,  
CHARLOTTESVILLE, VA 22902

PROJECT MANAGER Barbara Gehring barbara@ggpps.us 434-202-2392	DRAWN BY bg	REVIEWED BY CCK	PAPER SIZE & SCALE REFERENCE to be printed on 11x17
First Submission Date 7/7/2021	Project ID 1917	File Path C:\Users\barbara\Documents\734Locust\734Locust.dwg	
Revision 1 Date 7/16/2021	Revision 2 Date		

7/16/2021	BAR REVIEW SET	REV1: additional pages, see index on cover page A0.1, updated numbering, updated text.
-----------	----------------	--

PROJECT TITLE

**734 LOCUST AVE,  
CHARLOTTESVILLE  
CARRIAGE HOUSE  
RENOVATION**

SET NAME

**BAR REVIEW SET**

SHEET TITLE

**BEFORE AFTER  
SIDE YARD ELEVATION**

SHEET NUMBER

**A 2.5**

GENERAL CONTRACTOR

BONCRAFT BUILDERS LLC  
705 GRAVES STREET  
CHARLOTTESVILLE, VA 22902  
434-987-2549

ARCHITECT

GEHRUNG + GRAHAM LLC  
energy positive architecture  
2055 Foal Lane, Charlottesville, VA 22901 | www.gehrunggraham.com  
PHONE: 434-202-2392 EMAIL: barbara@gppa.us

STRUCTURAL ENGINEER

CURRY & ASSOCIATES  
120 RIVERBLUFF CIRCLE  
CHARLOTTESVILLE, VA 22902  
434-361-0180  
info@curryandassociates.com

OWNER

DR. KATHLEEN FREE  
734 LOCUST AVE,  
CHARLOTTESVILLE, VA 22902

PROJECT MANAGER Barbara Gehring barbara@gehrunggraham.com 434-202-2392	DRAWN BY bg	REVIEWED BY CCKK	PAPER SIZE & SCALE REFERENCE to be printed on 11x17
First Submission Date 7/7/2021/2021	Project ID 1917	File Path C:\Users\barbara\Documents\734 Locust Ave\734 Locust Ave.dwg	
Revision 1 Date 7/16/2021	Revision 2 Date		

7/16/2021 BAR REVIEW SET REV1: additional pages, see index on cover page A0.1, updated numbering, updated text.

PROJECT TITLE

734 LOCUST AVE,  
CHARLOTTESVILLE  
CARRIAGE HOUSE  
RENOVATION

SET NAME

BAR REVIEW SET

SHEET TITLE

GABLE ELEVATIONS  
REMODEL

SHEET NUMBER

A 2.6



HAZEL STREET (NORTH) ELEVATION PROPOSED  
SCALE: 1/4" = 1'-0"



SIDE YARD (SOUTH) ELEVATION PROPOSED  
SCALE: 1/4" = 1'-0"

GENERAL CONTRACTOR

BONCRAFT BUILDERS LLC  
705 GRAVES STREET  
CHARLOTTESVILLE, VA 22902  
434-987-2549

ARCHITECT

GEHRUNG + GRAHAM LLC  
energy positive architecture  
2055 Foal Lane, Charlottesville, VA 22901 | www.gehrungraham.com  
PHONE: 434-202-2392 EMAIL: barbara@gppa.us

STRUCTURAL ENGINEER

CURRY & ASSOCIATES  
120 RIVERBLUFF CIRCLE  
CHARLOTTESVILLE, VA 22902  
434-361-0180  
info@curryandassociates.com

OWNER

DR. KATHLEEN FREE  
734 LOCUST AVE,  
CHARLOTTESVILLE, VA 22902

PROJECT MANAGER Barbara Gehring barbara@gehrung.com 434-202-2392	DRAWN BY bg	REVIEWED BY CCK	PAPER SIZE & SCALE REFERENCE to be printed on 11x17
First Submission Date 7/7/2021	Project ID 1917	File Path C:\Users\barbara\Documents\734Locust\734Locust.dwg	
Revision 1 Date 7/16/2021	Revision 2 Date		

7/16/2021 BAR REVIEW SET REV1: additional pages, see index on cover page A0.1, updated numbering, updated text.

PROJECT TITLE

734 LOCUST AVE,  
CHARLOTTESVILLE  
CARRIAGE HOUSE  
RENOVATION

SET NAME

BAR REVIEW SET

SHEET TITLE

ALLEY ELEVATION  
REMODEL

SHEET NUMBER

A 2.7

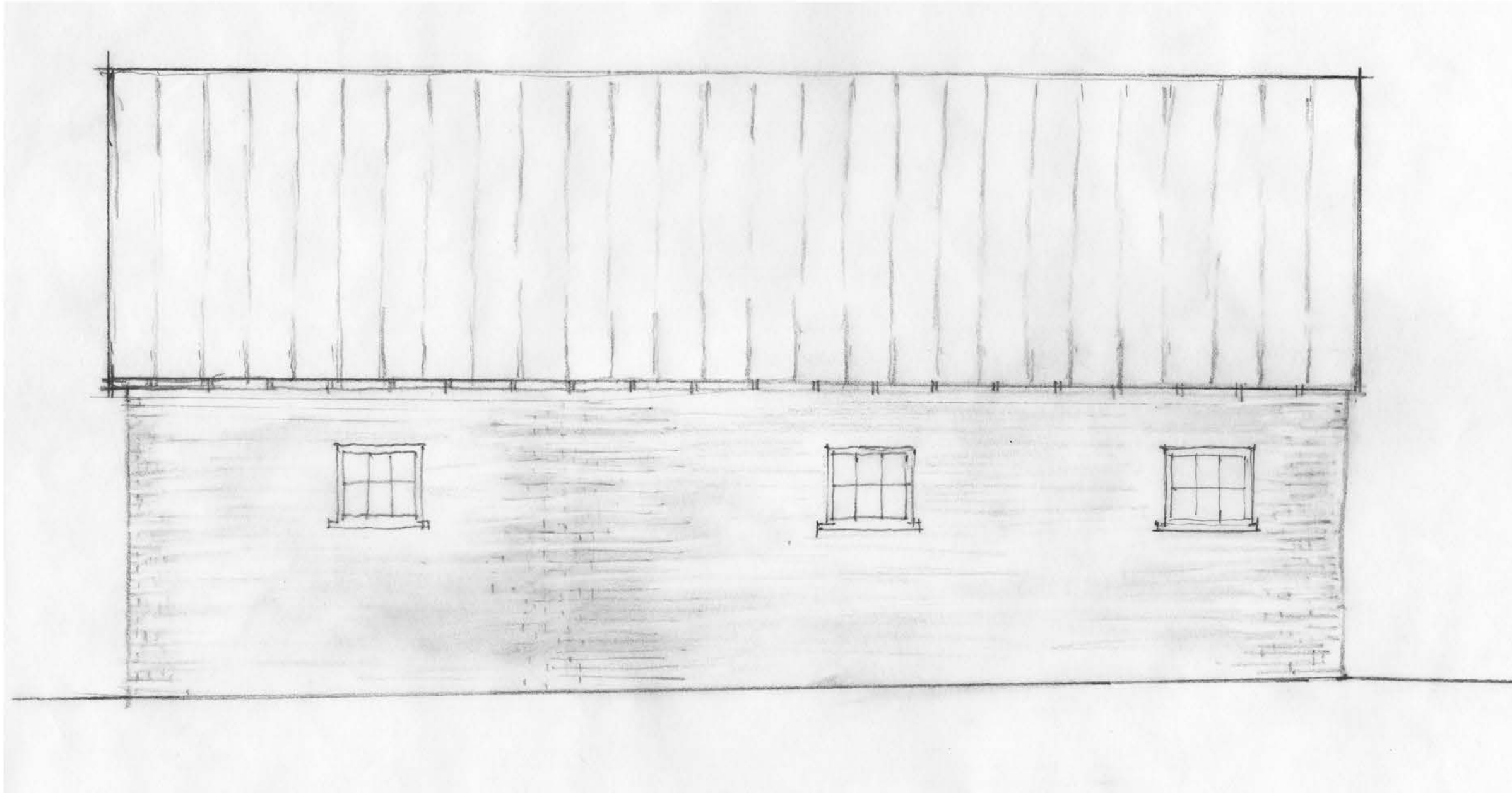

ALLEY (EAST) ELEVATION AS-BUILT & PROPOSED  
SCALE: 1/4" = 1'-0"

ELEVATION TO REMAIN AS-IS. EXISTING WINDOWS TO BE RESTORED.

**Certificate of Appropriateness**

BAR 21-07-03

743 Park Street, TMP 520052000

North Downtown ADC District

Owner: Amita Sudhir and Aaron M. Freilich

Applicant: Zach Snider, Alloy Architecture & Construction

Project: Remove metal siding and repair/replace original wood siding; storm window replacements

Application components (please click each link to go directly to PDF page):

- [Staff Report](#)
- [Historic Survey](#)
- [Application Submittal](#)

**City of Charlottesville  
Board of Architectural Review  
Staff Report  
July 20, 2021**



**Certificate of Appropriateness Application**

BAR 21-07-03

743 Park Street, TMP 520052000

North Downtown ADC District

Owner: Amita Sudhir and Aaron M. Freilich

Applicant: Zach Snider, Alloy Architecture & Construction

Project: Remove metal siding and repair/replace original wood siding; replace storm windows

---



**Background**

Year Built: c1892

District: North Downtown ADC District

Status: Contributing

R.H. Wood House, constructed in the Victorian vernacular style. The City's 1970s survey describes this house as an outstanding example of the Shingle Style popular in the 1880s and 1890s and one of the most distinctive structures on Park Street. (It also refers to the exterior clapboard siding that is now concealed by aluminum siding.)

**Prior BAR Review**

(see the Appendix)

**Application**

- Applicant submittal: Alloy Workshop narrative and photos, dated June 24, 2021 (five pages).

Request CoA to remove the existing aluminum siding and trim to expose original wood below. Then, as needed, repair existing or replace with cement board material. (This work excludes the 2014 addition.) Additionally, the storm windows on the original house are to be removed and replaced.

**Discussion and Recommendations**

Staff recommends approval of the requested CoA, but only after a discussion of the anticipated unknowns and establishing reasonable parameters for addressing them.

The goal of this project is to expose and rehabilitate the original trim and siding on this house. Should the condition of those materials limit or even preclude that goal, the intent is to replicate the existing (install new) to an extent that is reasonably possible. However, the condition and even the dimensional details of the historic siding and trim and to what extent those components even remain cannot be known until the aluminum siding and misc. flashing are removed.

Staff recommends the BAR allow the applicant to move forward with removing the metal and allowing an evaluation of the underlying materials, and with that to apply reasonable conditions that allow the rehabilitation and/or replacement of those materials. For example, that the salvageable wood siding be retained and used to the extent possible. In the event that only a portion of the siding can be salvaged—and in lieu of having walls with a mix of new cement board and salvaged wood siding--the BAR recommends the salvaged material be re-used on complete walls, prioritizing the front elevation. Once the aluminum is removed and the underlying conditions assessed, the applicant will consult with staff about the extent of old and new material to be used and where, with the understanding that staff may request guidance from the BAR. For any new siding, the applicant proposes a cement board product, which the BAR has approved for other applications, with the condition that the smooth side will be exposed, no faux grain.

Should the existing trim not be salvageable, particularly any profiled components, the applicant will consult with staff regarding the new material to be used and to assure that the new matches or is appropriately similar to the existing, relative to dimension and profile. Again, with the understanding that staff may request guidance from the BAR. More specifically, the BAR should discuss whether any replacement materials should replicate the existing (custom material, if necessary) or if it is acceptable to use available materials that have similar dimensions and profiles. For any replacement trim, the applicant proposes a product from Boral ([www.boralamerica.com](http://www.boralamerica.com)), which produces several lines of synthetic materials. (Staff requested that the applicant provide information regarding a specific product.)

The proposed storm windows are not specified, but they will be powder coated (white) aluminum, which is consistent with the guidelines. In approving the CoA, relative to the storm windows the BAR may apply the following conditions (from the design guidelines):

- Storm windows should match the size and shape of the existing windows and the original sash configuration. Special shapes, such as arched top storms, are available.
- Storm windows should not damage or obscure the windows and frames.

### **Suggested Motion**

*Approval:* Having considered the standards set forth within the City Code, including City Design Guidelines for ADC Districts, I move to find that the proposed exterior alterations at 743 Park Street satisfy the BAR's criteria and are compatible with this property and other properties in the Downtown ADC District, and that the BAR approves the application [as submitted.]

or [as submitted, with the following modifications and/or conditions:...]

*Denial:* Having considered the standards set forth within the City Code, including City Design Guidelines for ADC Districts, I move to find that the proposed exterior alterations at 743 Park Street do not satisfy the BAR's criteria and are not compatible with this property and other properties in the Downtown ADC District, and for the following reasons the BAR denies the application ...

## **Criteria, Standards and Guidelines**

### **Review Criteria Generally**

Sec. 34-284(b) of the City Code states that, in considering a particular application the BAR shall approve the application unless it finds:

- (1) That the proposal does not meet specific standards set forth within this division or applicable provisions of the Design Guidelines established by the board pursuant to Sec.34-288(6); and
- (2) The proposal is incompatible with the historic, cultural or architectural character of the district in which the property is located or the protected property that is the subject of the application.

### **Pertinent Standards for Review of Construction and Alterations include:**

- (1) Whether the material, texture, color, height, scale, mass and placement of the proposed addition, modification or construction are visually and architecturally compatible with the site and the applicable design control district;
- (2) The harmony of the proposed change in terms of overall proportion and the size and placement of entrances, windows, awnings, exterior stairs and signs;
- (3) The Secretary of the Interior Standards for Rehabilitation set forth within the Code of Federal Regulations (36 C.F.R. §67.7(b)), as may be relevant;
- (4) The effect of the proposed change on the historic district neighborhood;
- (5) The impact of the proposed change on other protected features on the property, such as gardens, landscaping, fences, walls and walks;
- (6) Whether the proposed method of construction, renovation or restoration could have an adverse impact on the structure or site, or adjacent buildings or structures;
- (7) Any applicable provisions of the City's Design Guidelines.

### **Pertinent Guidelines for Rehabilitation include:**

[http://weblink.charlottesville.org/public/0/edoc/793066/5\\_Chapter%20IV%20Rehabilitation\\_BAR.pdf](http://weblink.charlottesville.org/public/0/edoc/793066/5_Chapter%20IV%20Rehabilitation_BAR.pdf)

### **C. Windows**

- 16) Storm windows should match the size and shape of the existing windows and the original sash configuration. Special shapes, such as arched top storms, are available.
- 17) Storm windows should not damage or obscure the windows and frames.
- 18) Avoid aluminum-colored storm sash. It can be painted an appropriate color if it is first primed with a zinc chromate primer.

### **E. Cornice**

- 1) Keep the cornice well sealed and anchored, and maintain the gutter system and flashing.
- 2) Repair rather than replace the cornice.
- 3) Do not remove elements of the original composition, such as brackets or blocks, without replacing them with new ones of a like design.
- 4) Match materials, decorative details, and profiles of the existing original cornice design when making repairs.
- 5) Do not replace an original cornice with a new one that conveys a different period, style, or theme from that of the building.
- 6) If the cornice is missing, the replacement should be based on physical or documented evidence, or barring that, be compatible with the original building.
- 7) Do not wrap or cover a cornice with vinyl or aluminum; these substitute materials may cover up original details and also may hide underlying moisture problems.



## I. Wood

1. Repair rotted or missing sections rather than replace the entire element.
  - a. Use epoxies to patch, piece, or consolidate parts.
  - b. Match existing materials and details.
2. Replace wood elements only when they are rotted beyond repair.
  - a. Match the original in material and design by substituting materials that convey the same visual appearance or by using surviving material.
  - b. Base the design of reconstructed elements on pictorial or physical evidence from the actual building rather than from similar buildings in the area.
  - c. Complement the existing details, size, scale, and material.
3. Do not substitute vinyl for wood railing and trim. Some composites, including fiberglass reinforced composite, may be found acceptable as a substitute material for a specific application, but must be painted.

## J. Synthetic Siding

1. Avoid applying synthetic siding.
2. Remove synthetic siding and restore original building material, if possible.

## Appendix

### **Prior BAR Reviews**

January 21, 2014 - BAR approved (7-0) the request to demolish an outbuilding and to demolish the early 20th century, rear addition, subject to documentation. BAR accepted (7-0) the applicant's request to defer action on the proposed addition.

February 18, 2014 – BAR approved CoA for proposed addition (7-0-2 with Hogg and Graves abstaining), with the window color to be bronze, and the Hardie color to be submitted to staff for approval.

May 20, 2014 - BAR approved CoA to replace existing slate roof with standing-seam metal. BAR accepted (7-0) the applicant's request to defer.

July 15, 2014 – BAR approved CoA to replace existing slate roof with standing-seam metal, with turret roof to have flat seams.

# LANDMARK



# SURVEY

## IDENTIFICATION

Street Address: 743 Park Street  
 Map and Parcel: 52-52  
 Census Track & Block: 3-519  
 Present Owner: R. B. Hall & Barbara H. Hamner  
 Address: 743 Park Street  
 Present Use: Residence  
 Original Owner: R. H. Wood  
 Original Use: Residence

## BASE DATA

Historic Name: R. H. Wood House  
 Date/Period: cir. 1892  
 Style: Victorian Vernacular  
 Height to Cornice:  
 Height in Stories: 2 1/2  
 Present Zoning: R-1  
 Land Area (sq.ft.): 111 x 313  
 Assessed Value (land + imp.): 4500 + 16,080 = 20,580

## ARCHITECTURAL DESCRIPTION

The R. H. Wood House is one of the most architecturally distinctive structures on Park Street. It is an outstanding example of the Shingle Style popularized by H. H. Richardson and McKim, Meade, and White in the 1880's and 1890's. It is characterized by a rambling form, picturesque silhouette, and use of natural materials. The Wood House is a combination of clapboard and field stone. Its varied silhouette is created by contrasting the frame octagonal two story tower set into the sloping slate roof on the southern front of the house with the semi-circular fieldstone and wood tower on the north of the house. The facade is further enriched with a gabled Victorian veranda. The sides and rear of the house resemble a New England saltbox with overhanging floors and a shed roof form. This is the only example of a Shingle Style house in the historic district. It is doubtful that the exterior clapboarding was originally white; rather a more natural color.

## HISTORICAL DESCRIPTION

The lot upon which this home was built was originally part of the Hedges estate. Mrs. R. H. Wood (Isabel) was the daughter of C. H. Hedges, and the lot was given to her and her husband by her father about 1890. The home was built shortly thereafter. R. H. Wood died in 1928 and was followed by his wife in 1939. The house then passed to their 6 children who sold it to E. C. and Alma Wingfield in 1955 (DB 116-433). The property changed hands three times before the present owners purchased it beginning in 1961.

## GRAPHICS



## CONDITIONS

## SOURCES



# Board of Architectural Review (BAR) Certificate of Appropriateness

Please Return To: City of Charlottesville  
Department of Neighborhood Development Services  
P.O. Box 911, City Hall  
Charlottesville, Virginia 22902  
Telephone (434) 970-3130

Staff: [wernerjb@charlottesville.gov](mailto:wernerjb@charlottesville.gov)

Please submit ~~ten (10) hard copies~~ and one (1) digital copy of application form and all attachments.  
Please include application fee as follows: New construction project \$375; Demolition of a contributing structure \$375;  
Appeal of BAR decision \$125; Additions and other projects requiring BAR approval \$125; Administrative approval \$100.  
Make checks payable to the City of Charlottesville.  
The BAR meets the third Tuesday of the month.  
Deadline for submittals is Tuesday 3 weeks prior to next BAR meeting by 3:30 p.m.

Owner Name Amita Freilich and Aaron M Applicant Name Zach Snider/Alloy  
Project Name/Description Siding replacement Parcel Number 520052000  
Project Property Address 743 Park Street

### Applicant Information

Address: 1109 Rose Hill Dr, \_\_\_\_\_  
Charlottesville, VA 22903 \_\_\_\_\_  
Email: zach@alloyworkshop.com \_\_\_\_\_  
Phone: (W) 434-882-1968 \_\_\_\_\_

### Property Owner Information (if not applicant)

Address: 743 Park Street \_\_\_\_\_  
Charlottesville, VA 22902 \_\_\_\_\_  
Email: \_\_\_\_\_  
Phone: (W) \_\_\_\_\_ (C) \_\_\_\_\_  
-

Do you intend to apply for Federal or State Tax Credits  
for this project? no

### Signature of Applicant

I hereby attest that the information I have provided is, to the best of my knowledge, correct.

Zach Snider 6/25/2021  
Signature Date

Print Name Date

### Property Owner Permission (if not applicant)

I have read this application and hereby give my consent to its submission.

[Signature] 6/24/21  
Signature Date

Aaron Freilich 6/24/21  
Print Name Date

Description of Proposed Work (attach separate narrative if necessary):  
Removal of aluminum siding and restoration of the original existing wood siding and trim

List All Attachments (see reverse side for submittal requirements):  
\_\_\_\_\_  
\_\_\_\_\_

### **For Office Use Only**

Received by: \_\_\_\_\_

Fee paid: \_\_\_\_\_ Cash/Ck. # \_\_\_\_\_

Date Received: \_\_\_\_\_

Revised 2016

Approved/Disapproved by: \_\_\_\_\_

Date: \_\_\_\_\_

Conditions of approval: \_\_\_\_\_



24 June 2021  
Alloy Architecture & Construction LLC  
1109 Rose Hill Drive  
Charlottesville Va 22903

Board of Architectural Review  
City of Charlottesville NDS  
P.O. Box 911, City Hall  
Charlottesville VA 22902

#### Explanation of Proposed Work.

The intent is to remove the existing Aluminum siding and trim. Depending on the condition of the existing we will repair the existing or replace with new cement board siding. No repair work will be done on the 2014 addition.

If existing wood siding under aluminum is deteriorated to a point that it can not be repaired, we will replace all of the siding and trim with new cement board siding, and Boral trim. New siding and trim will match original wood siding and trim to the extent possible with currently available materials.

All storm windows on the original house will be replaced with new similar aluminum white powder coated storm windows.





Add new Ogee Style gutter

Repaint existing

Remove aluminum and repair existing wood siding and trim

## ARCHITECTURE + CONSTRUCTION

1109 Rose Hill Drive · Charlottesville, Virginia 22903 · 434-977-8733 · [alloyworkshop.com](http://alloyworkshop.com)





Expose and evaluate existing trim details and materials. Restore and repaint to the extent possible.

Repaint addition

Replace all existing storm windows

Repaint existing shingle details

**ARCHITECTURE + CONSTRUCTION**

1109 Rose Hill Drive · Charlottesville, Virginia 22903 · 434-977-8733 · [alloyworkshop.com](http://alloyworkshop.com)





Expose and evaluate existing trim details and materials. Restore and repaint to the extent possible.

Replace all existing storm windows

**ARCHITECTURE + CONSTRUCTION**

1109 Rose Hill Drive · Charlottesville, Virginia 22903 · 434-977-8733 · [alloyworkshop.com](http://alloyworkshop.com)





Expose and evaluate existing trim details and materials. Restore and repaint to the extent possible.

Replace all existing storm windows

**ARCHITECTURE + CONSTRUCTION**

1109 Rose Hill Drive · Charlottesville, Virginia 22903 · 434-977-8733 · [alloyworkshop.com](http://alloyworkshop.com)





## **Certificate of Appropriateness**

BAR 21-07-05

350 Park Street, TMP 530109000 and 530108000

North Downtown ADC District

Owner: City of Charlottesville and County of Albemarle

Applicant: Eric Amtmann, Dalglish-Gilpin-Paxton Architects [on behalf of Albemarle County]

Project: New courthouse building (at Levy Building)

Application components (please click each link to go directly to PDF page):

- [Staff Report](#)
- [Historic Survey](#)
- [Application Submittal](#)

**City of Charlottesville  
Board of Architectural Review  
Staff Report  
July 20, 2021**



**Certificate of Appropriateness Application**

BAR 21-07-05

350 Park Street, TMP 530109000 and 530108000

North Downtown ADC District

Owner: City of Charlottesville and County of Albemarle

Applicant: Eric Amtmann, Dalgliesh-Gilpin-Paxton Architects [on behalf of Albemarle County]

Project: New courthouse building (at Levy Building)



**Background**

350 Park Street

*Year Built:* Levy Building 1852, Annex c1980

*District:* North Downtown ADC District

*Status:* Contributing

0 Park Street

*Year Built:* N/A, parking lot

*District:* North Downtown ADC District

*Status:* N/A

The Levy Building is Greek Revival, constructed with brick laid in American bond with a Flemish bond variant. Three stories with a hipped roof, three-bay front, heavy entablature supported by monumental stuccoed pilasters on brick pedestals, crosette architraves, and brick water table.

**Prior BAR Reviews** (See Appendix for all)

October 20, 2020 – Pre-application discussion re: planned City-County Courts Complex, including necessary selective demolition of the Levy Building’s hyphen and annex. No action taken.

December 15, 2020 – BAR approved CoA for selective demolition of the Levy Building hyphen and east annex. (See Appendix for approved motion.)

**Application**

- Applicant submitted: Fentress Architects drawing and presentation *Albemarle County & Charlottesville City General District Courts Complex*, dated Jun 29, 2021 (40 pages).

CoA request for construction of addition to the Levy Building and new construction related to the new City-County Courts Complex.

## **Discussion**

While this is a formal CoA request, the applicant has acknowledged that this meeting—and, possibly, subsequent meetings—will be treated as an intermediate review and that no formal BAR action will be taken. However, by consensus the BAR may express an opinion about the project as presented. (For example, the BAR may take a non-binding vote to express support, opposition, or even questions and concerns regarding the project’s likelihood for an approved CoA. These will not represent approval or even endorsement of the CoA, but will represent the BAR’s opinion on the project, relative to preparing the project for final submittal. While such votes carry no legal bearing and are not binding, BAR members are expected to express their opinions—both individually and collectively--in good faith as a project advances towards an approved CoA.)

This is an iterative process and these discussions should be thorough and productive. The goal is to establish what is necessary for a final submittal that provides the information necessary for the BAR to evaluate the project and to then approve or deny the requested CoA.

In response to any questions from the applicant and/or for any recommendations to the applicant, the BAR should rely on the germane sections of the ADC District Design Guidelines and related review criteria. While elements of other chapters may be relevant, staff recommends that the BAR refer to the criteria in Chapter II--*Site Design and Elements*, Chapter III--*New Construction and Additions*, and Chapter VI – *Public Design and Improvements*.

Of particular assistance for this discussion are the criteria in Chapter III:

- Setback, including landscaping and site improvements
- Spacing
- Massing and Footprint
- Height and Width
- Scale
- Roof
- Orientation
- Windows and Doors
- Street-Level Design
- Foundation and Cornice
- Materials and Textures
- Paint [Color palette]
- Details and Decoration, including lighting and signage

Also, the criteria under *Public Buildings and Structures*, in Chapter VI

- Public buildings should follow design guidelines for new construction.
- New structures, including bridges, should reflect contemporary design principles.

## **Suggested Motions**

Staff recommends no formal action, except to defer this matter. (With an applicant’s request for deferral, there is no calendar requirement for when the application returns to the BAR. In the absence of an applicant requested deferral and the BAR defers it, the application must be presented at the next meeting.)

## **Criteria, Standards, and Guidelines**

### **Review Criteria Generally**

Sec. 34-284(b) of the City Code states that, in considering a particular application the BAR shall approve the application unless it finds:

- (1) That the proposal does not meet specific standards set forth within this division or applicable provisions of the Design Guidelines established by the board pursuant to Sec.34-288(6); and
- (2) The proposal is incompatible with the historic, cultural or architectural character of the district in which the property is located or the protected property that is the subject of the application.

**Pertinent Standards for Review of Construction and Alterations include:**

- (1) Whether the material, texture, color, height, scale, mass and placement of the proposed addition, modification or construction are visually and architecturally compatible with the site and the applicable design control district;
- (2) The harmony of the proposed change in terms of overall proportion and the size and placement of entrances, windows, awnings, exterior stairs and signs;
- (3) The Secretary of the Interior Standards for Rehabilitation set forth within the Code of Federal Regulations (36 C.F.R. §67.7(b)), as may be relevant;
- (4) The effect of the proposed change on the historic district neighborhood;
- (5) The impact of the proposed change on other protected features on the property, such as gardens, landscaping, fences, walls and walks;
- (6) Whether the proposed method of construction, renovation or restoration could have an adverse impact on the structure or site, or adjacent buildings or structures;
- (7) Any applicable provisions of the City’s Design Guidelines.

**Pertinent ADC District Design Guidelines**

Links to the guidelines

[I: Introduction \(Part 1\)](#)

[II: Introduction \(Part 2\)](#)

[III: Site Design and Elements](#)

[IV: New Construction and Additions](#)

[V: Rehabilitation](#)

[VI: Signs, Awnings, Vending, and Cafes](#)

[VII: Public Improvements](#)

[VIII: Moving and Demolition](#)

[IX: Index](#)

Chapter II – Site Design and Elements

A. Introduction

The relationship between a historic building and its site, landscape features, outbuildings, and other elements within the property boundary all contribute to a historic district’s overall image. Site features should be considered an important part of any project to be reviewed by the Board of Architectural Review.

There is much variety in site design and elements between and within the various historic districts in Charlottesville. The commercial areas of the downtown mall, West Main Street Corridor and the Corner, generally have few site features since the buildings usually cover much of the lot and have very limited setbacks. The early nineteenth century rowhouses near the courthouse are similar to commercial lot coverage with the exception that some may have a very small front yard with limited foundation or ground cover plantings.

Many of the nineteenth century dwellings in the North Downtown area and along parts of Ridge and Wertland streets also have limited setbacks and are spaced closely together. In these cases there are small front yards composed of grass or ground cover and often containing large canopy trees. The

edges of these areas often are planted with low shrubs or flower beds, and the houses are surrounded by foundation plantings. Iron fences, hedges or low stone walls may separate the homeowner's property from the public sidewalk.

In other parts of the North Downtown area, particularly along Park Street, many of the dwellings are sited on larger lots and are placed further back on the lot. In these cases the front yard is a large lawn defined by border plantings and usually a low stone retaining wall or iron fence. Some have larger boxwood hedges and rows of box defining the entrance walkway. Large canopy trees, smaller ornamental trees and flower beds are additional elements often found within these spaces.

The resulting character of many of the residential streets in the historic districts is one of lush plantings and mature shade trees. While there may be much variety within the house types and styles along a particular street, the landscape character ties together the setting and plays an important role in defining the distinctiveness of the districts.

When making changes to a property within one of the historic districts, the entire site should be studied to better understand its original design and its context within its sub-area. When planning changes to a site in a historic district, create a new plan that reflects the site traditions of the area and that fits the scale of the lot. Consider using different types and scales of plantings that will create scale, define edges and enclose outdoor spaces of the site. The following sections provide more specific guidance.

The elements of urban landscapes, parks, and other open spaces in public ownership, including sidewalks, streets, plantings, street furniture, and street lighting also contribute to the character of the district and are discussed in Chapter 6: Public Improvements.

#### B. Plantings

- 1) Encourage the maintenance and planting of large trees on private property along the streetfronts, which contribute to the "avenue" effect.
- 2) Generally, use trees and plants that are compatible with the existing plantings in the neighborhood.
- 3) Use trees and plants that are indigenous to the area.
- 4) Retain existing trees and plants that help define the character of the district, especially street trees and hedges.
- 5) Replace diseased or dead plants with like or similar species if appropriate.
- 6) When constructing new buildings, identify and take care to protect significant existing trees and other plantings.
- 7) Choose ground cover plantings that are compatible with adjacent sites, existing site conditions, and the character of the building.
- 8) Select mulching and edging materials carefully and do not use plastic edgings, lava, crushed rock, unnaturally colored mulch or other historically unsuitable materials.

#### C. Walls and Fences

- 1) Maintain existing materials such as stone walls, hedges, wooden picket fences, and wrought-iron fences.
- 2) When a portion of a fence needs replacing, salvage original parts for a prominent location.
- 3) Match old fencing in material, height, and detail.
- 4) If it is not possible to match old fencing, use a simplified design of similar materials and height.
- 5) For new fences, use materials that relate to materials in the neighborhood.
- 6) Take design cues from nearby historic fences and walls.
- 7) Chain-link fencing, split rail fences, and vinyl plastic fences should not be used.

- 8) Traditional concrete block walls may be appropriate.
- 9) Modular block wall systems or modular concrete block retaining walls are strongly discouraged but may be appropriate in areas not visible from the public right-of-way.
- 10) If street-front fences or walls are necessary or desirable, they should not exceed four (4) feet in height from the sidewalk or public right-of-way and should use traditional materials and design.
- 11) Residential privacy fences may be appropriate in side or rear yards where not visible from the primary street.
- 12) Fences should not exceed six (6) feet in height in the side and rear yards.
- 13) Fence structures should face the inside of the fenced property.
- 14) Relate commercial privacy fences to the materials of the building. If the commercial property adjoins a residential neighborhood, use a brick or painted wood fence or heavily planted screen as a buffer.
- 15) Avoid the installation of new fences or walls if possible in areas where there are no fences or walls and yards are open.
- 16) Retaining walls should respect the scale, materials and context of the site and adjacent properties.
- 17) Respect the existing conditions of the majority of the lots on the street in planning new construction or a rehabilitation of an existing site.

#### D. Lighting

- 1) In residential areas, use fixtures that are understated and compatible with the residential quality of the surrounding area and the building while providing subdued illumination.
- 2) Choose light levels that provide for adequate safety yet do not overly emphasize the site or building. Often, existing porch lights are sufficient.
- 3) In commercial areas, avoid lights that create a glare. High intensity commercial lighting fixtures must provide full cutoff.
- 4) Do not use numerous “crime” lights or bright floodlights to illuminate a building or site when surrounding lighting is subdued.
- 5) In the downtown and along West Main Street, consider special lighting of key landmarks and facades to provide a focal point in evening hours.
- 6) Encourage merchants to leave their display window lights on in the evening to provide extra illumination at the sidewalk level.
- 7) Consider motion-activated lighting for security.

#### E. Walkways and Driveways

- 1) Use appropriate traditional paving materials like brick, stone, and scored concrete.
- 2) Concrete pavers are appropriate in new construction, and may be appropriate in site renovations, depending on the context of adjacent building materials, and continuity with the surrounding site and district.
- 3) Gravel or stone dust may be appropriate, but must be contained.
- 4) Stamped concrete and stamped asphalt are not appropriate paving materials.
- 5) Limit asphalt use to driveways and parking areas.
- 6) Place driveways through the front yard only when no rear access to parking is available.
- 7) Do not demolish historic structures to provide areas for parking.
- 8) Add separate pedestrian pathways within larger parking lots, and provide crosswalks at vehicular lanes within a site.

#### F. Parking Areas and Lots

- 1) If new parking areas are necessary, construct them so that they reinforce the street wall of buildings and the grid system of rectangular blocks in commercial areas.

- 2) Locate parking lots behind buildings.
- 3) Screen parking lots from streets, sidewalks, and neighboring sites through the use of walls, trees, and plantings of a height and type appropriate to reduce the visual impact year-round.
- 4) Avoid creating parking areas in the front yards of historic building sites.
- 5) Avoid excessive curb cuts to gain entry to parking areas.
- 6) Avoid large expanses of asphalt.
- 7) On large lots, provide interior plantings and pedestrian walkways.
- 8) Provide screening from adjacent land uses as needed.
- 9) Install adequate lighting in parking areas to provide security in evening hours.
- 10) Select lighting fixtures that are appropriate to a historic setting.

#### H. Utilities and Other Site Appurtenances

1. Plan the location of overhead wires, utility poles and meters, electrical panels, antennae, trash containers, and exterior mechanical units where they are least likely to detract from the character of the site.
2. Screen utilities and other site elements with fences, walls, or plantings.
3. Encourage the installation of utility services underground.
4. Antennae and communication dishes should be placed in inconspicuous rooftop locations, not in a front yard.
5. Screen all rooftop mechanical equipment with a wall of material harmonious with the building or structure.

### Chapter III – New Construction and Additions

#### A. Introduction

The following guidelines offer general recommendations on the design for all new buildings and additions in Charlottesville's historic districts. The guidelines are flexible enough to both respect the historic past and to embrace the future. The intent of these guidelines is not to be overly specific or to dictate certain designs to owners and designers. The intent is also not to encourage copying or mimicking particular historic styles. These guidelines are intended to provide a general design framework for new construction. Designers can take cues from the traditional architecture of the area, and have the freedom to design appropriate new architecture for Charlottesville's historic districts. These criteria are all important when considering whether proposed new buildings are appropriate and compatible; however, the degree of importance of each criterion varies within each area as conditions vary.

For instance, setback and spacing between buildings may be more important than roof forms or materials since there is more variety of the last two criteria on most residential streets. All criteria need not be met in every example of new construction although all criteria should be taken into consideration in the design process. When studying the character of a district, examine the forms of historic contributing buildings and avoid taking design cues from non-contributing structures.

There may be the opportunity for more flexibility in designing new buildings or making an addition depending on the level of historic integrity of a particular area. Some parts of the historic districts retain a high degree of their original historic character. In these areas care should be taken to ensure that the new design does not visually overpower its historic neighboring buildings. In other areas where there are more non-contributing structures or more commercial utilitarian buildings, new designs could be more contemporary and the Board of Architectural Review (BAR) may be more flexible in applying these guidelines. Thus, the overall context of historic integrity of an area needs to

be understood and considered on an individual basis and what may be appropriate in some areas may not be appropriate in others.

According to the Secretary of the Interior's Standards for Rehabilitation:

- New additions, exterior alterations, or related new construction shall not destroy historic materials that characterize the property. The new work shall be differentiated from the old and shall be compatible with the massing, size, scale, and architectural features to protect the historic integrity of the property and its environment.
- New additions and adjacent or related new construction shall be undertaken in such a manner that, if removed in the future, the essential form and integrity of the historic property and its environment would be unimpaired.

## 1. Sustainability

Sustainability means meeting the needs of the present without compromising the ability of future generations to meet their own needs. Green building means building practices that use energy, water, and other resources wisely. The City of Charlottesville and the Board of Architectural Review support the principles of green building and sustainable design in order to create a community that is healthy, livable, and affordable:

- Preservation is the most sustainable choice. Adaptive reuse of a historic building or living in a pre-owned home reduces consumption of land and materials for new construction, and may reduce housing costs.
- Durable building materials such as brick, wood, cementitious siding, and metal roofs are economical and more compatible with the character of the community.
- Mixed-use development provides an alternative to sprawl that allows residents to live within walking distance of activities, thereby reducing time spent in the car.
- Infill development is an efficient use of land that can provide diversity in housing sizes and types, and can revitalize neighborhoods.
- Options for walking, bicycling, and transit promote healthy living and reduce dependence on automobiles and energy use.
- Designing buildings for the local climate helps conserve energy.
- Locally obtained building materials, rapidly renewable or recycled materials, non-toxic materials and finishes, and wood certified by the Forest Stewardship Council provide sustainable choices.
- Alternative construction techniques, such as structural insulated panels (SIPS), are energy efficient.
- Low impact development methods (porous pavement, rain gardens, vegetated buffers, green roofs) retain storm water on site and protect street water quality by filtering runoff.
- Use of rating systems such as LEED, Energy Star, and EarthCraft House are encouraged.

Sustainability and preservation are complementary concepts, and both goals should be pursued.

Nothing in these guidelines should be construed to discourage green building or sustainable design. If such a design is found to conflict with a specific guideline, the BAR shall work with the applicant to devise a creative design solution that meets the applicant's goals for sustainability, and that is compatible with the character of the district and the property.

## 2. Flexibility

The following guidelines offer general recommendations on the design for all new buildings and additions in Charlottesville's historic districts. The guidelines are flexible enough to both respect the historic past and to embrace the future. The intent of these guidelines is not to be overly specific or to dictate certain designs to owners and designers. The intent is also not to encourage copying or



mimicking particular historic styles. These guidelines are intended to provide a general design framework for new construction. Designers can take cues from the traditional architecture of the area and have the freedom to design appropriate new architecture for Charlottesville's historic districts.

### 3. Building Types within the Historic Districts

When designing new buildings in the historic districts, one needs to recognize that while there is an overall distinctive district character, there is, nevertheless, a great variety of historic building types, styles, and scales throughout the districts and sub-areas that are described in Chapter 1: Introduction. Likewise, there are several types of new construction that might be constructed within the districts the design parameters of these new buildings will differ depending on the following types:

d. Institutional: Government buildings, churches, schools, and libraries are all structures that represent a unique aspect of community life and frequently have special requirements that relate to their distinct uses. For these reasons, these buildings usually are freestanding and their scale and architectural arrangements may be of a different nature than their residential and historic neighbors, but their materials should blend with the character of the districts.

#### e. Multi-lot

Often new commercial, office, or multiuse buildings will be constructed on sites much larger than the traditionally sized lots 25 to 40 feet wide. Many sites for such structures are located on West Main Street and in the 14th and 15th Street area of Venable Neighborhood. These assembled parcels can translate into new structures whose scale and mass may overwhelm neighboring existing structures. Therefore, while this building type may need to respond to the various building conditions of the site, it also should employ design techniques to reduce its visual presence. These could include varying facade wall planes, differing materials, stepped-back upper levels, and irregular massing.

### B. Setback

- 1) Construct new commercial buildings with a minimal or no setback in order to reinforce the traditional street wall.
- 2) Use a minimal setback if the desire is to create a strong street wall or setback consistent with the surrounding area.
- 3) Modify setback as necessary for sub-areas that do not have well-defined street walls.
- 4) Avoid deep setbacks or open corner plazas on corner buildings in the downtown in order to maintain the traditional grid of the commercial district.
- 5) In the West Main Street corridor, construct new buildings with a minimal (up to 15 feet according to the zoning ordinance) or no setback in order to reinforce the street wall. If the site adjoins historic buildings, consider a setback consistent with these buildings.
- 6) On corners of the West Main Street corridor, avoid deep setbacks or open corner plazas unless the design contributes to the pedestrian experience or improves the transition to an adjacent residential area.
- 7) New buildings, particularly in the West Main Street corridor, should relate to any neighborhoods adjoining them. Buffer areas should be considered to include any screening and landscaping requirements of the zoning ordinance.
- 8) At transitional sites between two distinctive areas of setback, for instance between new commercial and historic commercial, consider using setbacks in the new construction that reinforce and relate to setbacks of the historic buildings.

- 9) For new governmental or institutional buildings, either reinforce the street wall through a minimal setback, or use a deep setback within a landscaped area to emphasize the civic function of the structure.
- 10) Keep residential setbacks within 20 percent of the setbacks of a majority of neighborhood dwellings.

#### C. Spacing

- 1) Maintain existing consistency of spacing in the area. New residences should be spaced within 20 percent of the average spacing between houses on the block.
- 2) Commercial and office buildings in the areas that have a well-defined street wall should have minimal spacing between them.
- 3) In areas that do not have consistent spacing, consider limiting or creating a more uniform spacing in order to establish an overall rhythm.
- 4) Multi-lot buildings should be designed using techniques to incorporate and respect the existing spacing on a residential street.

#### D. Massing and Footprint

- 1) New commercial infill buildings' footprints will be limited by the size of the existing lot in the downtown or along the West Main Street corridor. Their massing in most cases should be simple rectangles like neighboring buildings.
- 2) New infill construction in residential sub-areas should relate in footprint and massing to the majority of surrounding historic dwellings.
- 3) Neighborhood transitional buildings should have small building footprints similar to nearby dwellings.
  - a. If the footprint is larger, their massing should be reduced to relate to the smaller-scaled forms of residential structures.
  - b. Techniques to reduce massing could include stepping back upper levels, adding residential roof and porch forms, and using sympathetic materials.
- 4) Institutional and multi-lot buildings by their nature will have large footprints, particularly along the West Main Street corridor and in the 14<sup>th</sup> and 15<sup>th</sup> Street area of the Venable neighborhood.
  - a. The massing of such a large scale structure should not overpower the traditional scale of the majority of nearby buildings in the district in which it is located.
  - b. Techniques could include varying the surface planes of the buildings, stepping back the buildings as the structure increases in height, and breaking up the roof line with different elements to create smaller compositions.

#### E. Height and Width

- 1) Respect the directional expression of the majority of surrounding buildings. In commercial areas, respect the expression of any adjacent historic buildings, which generally will have a more vertical expression.
- 2) Attempt to keep the height and width of new buildings within a maximum of 200 percent of the prevailing height and width in the surrounding sub-area.
- 3) In commercial areas at street front, the height should be within 130 percent of the prevailing average of both sides of the block. Along West Main Street, heights should relate to any adjacent contributing buildings. Additional stories should be stepped back so that the additional height is not readily visible from the street.
- 4) When the primary façade of a new building in a commercial area, such as downtown, West Main Street, or the Corner, is wider than the surrounding historic buildings or the traditional lot size, consider modulating it with bays or varying planes.

- 5) Reinforce the human scale of the historic districts by including elements such as porches, entrances, storefronts, and decorative features depending on the character of the particular sub-area.

#### F. Scale

- 1) Provide features on new construction that reinforce the scale and character of the surrounding area, whether human or monumental. Include elements such as storefronts, vertical and horizontal divisions, upper story windows, and decorative features.
- 2) As an exception, new institutional or governmental buildings may be more appropriate on a monumental scale depending on their function and their site conditions.

#### G. Roof

##### 1) Roof Forms and Pitches

- a. The roof design of new downtown or West Main Street commercial infill buildings generally should be flat or sloped behind a parapet wall.
- b. Neighborhood transitional buildings should use roof forms that relate to the neighboring residential forms instead of the flat or sloping commercial form.
- c. Institutional buildings that are freestanding may have a gable or hipped roof with variations.
- d. Large-scale, multi-lot buildings should have a varied roof line to break up the mass of the design using gable and/or hipped forms.
- e. Shallow pitched roofs and flat roofs may be appropriate in historic residential areas on a contemporary designed building.
- f. Do not use mansard-type roofs on commercial buildings; they were not used historically in Charlottesville's downtown area, nor are they appropriate on West Main Street.

##### 2) Roof Materials: Common roof materials in the historic districts include metal, slate, and composition shingles.

- a. For new construction in the historic districts, use traditional roofing materials such as standing-seam metal or slate.
- b. In some cases, shingles that mimic the appearance of slate may be acceptable.
- c. Pre-painted standing-seam metal roof material is permitted, but commercial-looking ridge caps or ridge vents are not appropriate on residential structures.
- d. Avoid using thick wood cedar shakes if using wood shingles; instead, use more historically appropriate wood shingles that are thinner and have a smoother finish.
- e. If using composition asphalt shingles, do not use light colors. Consider using neutral-colored or darker, plain or textured-type shingles.
- f. The width of the pan and the seam height on a standing-seam metal roof should be consistent with the size of pan and seam height usually found on a building of a similar period.

##### 3) Rooftop Screening

- a. If roof-mounted mechanical equipment is used, it should be screened from public view on all sides.
- b. The screening material and design should be consistent with the design, textures, materials, and colors of the building.
- c. The screening should not appear as an afterthought or addition to the building.

#### H. Orientation

- 1) New commercial construction should orient its façade in the same direction as adjacent historic buildings, that is, to the street.
- 2) Front elevations oriented to side streets or to the interior of lots should be discouraged.

## I. Windows and Doors

- 1) The rhythm, patterns, and ratio of solids (walls) and voids (windows and doors) of new buildings should relate to and be compatible with adjacent historic facades.
  - a. The majority of existing buildings in Charlottesville's historic districts have a higher proportion of wall area than void area except at the storefront level.
  - b. In the West Main Street corridor in particular, new buildings should reinforce this traditional proportion.
- 2) The size and proportion, or the ratio of width to height, of window and door openings on new buildings' primary facades should be similar and compatible with those on surrounding historic facades.
  - a. The proportions of the upper floor windows of most of Charlottesville's historic buildings are more vertical than horizontal.
  - b. Glass storefronts would generally have more horizontal proportions than upper floor openings.
- 3) Traditionally designed openings generally are recessed on masonry buildings and have a raised surround on frame buildings. New construction should follow these methods in the historic districts as opposed to designing openings that are flush with the rest of the wall.
- 4) Many entrances of Charlottesville's historic buildings have special features such as transoms, sidelights, and decorative elements framing the openings. Consideration should be given to incorporating such elements in new construction.
- 5) Darkly tinted mirrored glass is not an appropriate material for windows in new buildings within the historic districts.
- 6) If small-paned windows are used, they should have true divided lights or simulated divided lights with permanently affixed interior and exterior muntin bars and integral spacer bars between the panes of glass.
- 7) Avoid designing false windows in new construction.
- 8) Appropriate material for new windows depends upon the context of the building within a historic district, and the design of the proposed building. Sustainable materials such as wood, aluminum-clad wood, solid fiberglass, and metal windows are preferred for new construction. Vinyl windows are discouraged.
- 9) Glass shall be clear. Opaque spandrel glass or translucent glass may be approved by the BAR for specific applications.

## K. Street-Level Design

- 1) Street level facades of all building types, whether commercial, office, or institutional, should not have blank walls; they should provide visual interest to the passing pedestrian.
- 2) When designing new storefronts or elements for storefronts, conform to the general configuration of traditional storefronts depending on the context of the sub-area. New structures do offer the opportunity for more contemporary storefront designs.
- 3) Keep the ground level facades(s) of new retail commercial buildings at least eighty percent transparent up to a level of ten feet.
- 4) Include doors in all storefronts to reinforce street level vitality.
- 5) Articulate the bays of institutional or office buildings to provide visual interest.
- 6) Institutional buildings, such as city halls, libraries, and post offices, generally do not have storefronts, but their street levels should provide visual interest and display space or first floor windows should be integrated into the design.
- 7) Office buildings should provide windows or other visual interest at street level.
- 8) Neighborhood transitional buildings in general should not have transparent first floors, and the design and size of their façade openings should relate more to neighboring residential structures.

- 9) Along West Main Street, secondary (rear) facades should also include features to relate appropriately to any adjacent residential areas.
- 10) Any parking structures facing on important streets or on pedestrian routes must have storefronts, display windows, or other forms of visual relief on the first floors of these elevations.
- 11) A parking garage vehicular entrance/exit opening should be diminished in scale, and located off to the side to the degree possible.

#### L. Foundation and Cornice

- 1) Distinguish the foundation from the rest of the structure through the use of different materials, patterns, or textures.
- 2) Respect the height, contrast of materials, and textures of foundations on surrounding historic buildings.
- 3) If used, cornices should be in proportion to the rest of the building.
- 4) Wood or metal cornices are preferred. The use of fypon may be appropriate where the location is not immediately adjacent to pedestrians.

#### M. Materials and Textures

- 1) The selection of materials and textures for a new building should be compatible with and complementary to neighboring buildings.
- 2) In order to strengthen the traditional image of the residential areas of the historic districts, brick, stucco, and wood siding are the most appropriate materials for new buildings.
- 3) In commercial/office areas, brick is generally the most appropriate material for new structures. "Thin set" brick is not permitted. Stone is more commonly used for site walls than buildings.
- 4) Large-scale, multi-lot buildings, whose primary facades have been divided into different bays and planes to relate to existing neighboring buildings, can have varied materials, shades, and textures.
- 5) Synthetic siding and trim, including, vinyl and aluminum, are not historic cladding materials in the historic districts, and their use should be avoided.
- 6) Cementitious siding, such as HardiPlank boards and panels, are appropriate.
- 7) Concrete or metal panels may be appropriate.
- 8) Metal storefronts in clear or bronze are appropriate.
- 9) The use of Exterior Insulation and Finish Systems (EIFS) is discouraged but may be approved on items such as gables where it cannot be seen or damaged. It requires careful design of the location of control joints.
- 10) The use of fiberglass-reinforced plastic is discouraged. If used, it must be painted.
- 11) All exterior trim woodwork, decking and flooring must be painted, or may be stained solid if not visible from public right-of-way.

#### N. Paint

- 1) The selection and use of colors for a new building should be coordinated and compatible with adjacent buildings, not intrusive.
- 2) In Charlottesville's historic districts, various traditional shaded of brick red, white, yellow, tan, green, or gray are appropriate. For more information on colors traditionally used on historic structures and the placement of color on a building, see Chapter 4: Rehabilitation.
- 3) Do not paint unpainted masonry surfaces.
- 4) It is proper to paint individual details different colors.
- 5) More lively color schemes may be appropriate in certain sub-areas dependent on the context of the sub-areas and the design of the building.

#### O. Details and Decoration

- 1) Building detail and ornamentation should be consistent with and related to the architecture of the surrounding context and district.
- 2) The mass of larger buildings may be reduced using articulated design details.
- 3) Pedestrian scale may be reinforced with details.

#### P. Additions

Many of the smaller commercial and other business buildings may be enlarged as development pressure increases in downtown Charlottesville and along West Main Street. These existing structures may be increased in size by constructing new additions on the rear or side or in some cases by carefully adding on extra levels above the current roof. The design of new additions on all elevations that are prominently visible should follow the guidelines for new construction as described earlier in this section. Several other considerations that are specific to new additions in the historic districts are listed below:

- 1) Function and Size
  - a. Attempt to accommodate needed functions within the existing structure without building an addition.
  - b. Limit the size of the addition so that it does not visually overpower the existing building.
- 2) Location
  - a. Attempt to locate the addition on rear or side elevations that are not visible from the street.
  - b. If additional floors are constructed on top of a building, set the addition back from the main façade so that its visual impact is minimized.
  - c. If the addition is located on a primary elevation facing the street or if a rear addition faces a street, parking area, or an important pedestrian route, the façade of the addition should be treated under the new construction guidelines.
- 3) Design
  - a. New additions should not destroy historic materials that characterize the property.
  - b. The new work should be differentiated from the old and should be compatible with the massing, size, scale, and architectural features to protect the historic integrity of the property and its environment.
- 4) Replication of Style
  - a. A new addition should not be an exact copy of the design of the existing historic building. The design of new additions can be compatible with and respectful of existing buildings without being a mimicry of their original design.
  - b. If the new addition appears to be part of the existing building, the integrity of the original historic design is compromised and the viewer is confused over what is historic and what is new.
- 5) Materials and Features
  - a. Use materials, windows, doors, architectural detailing, roofs, and colors that are compatible with historic buildings in the district.
- 6) Attachment to Existing Building
  - a. Wherever possible, new additions or alterations to existing buildings should be done in such a manner that, if such additions or alterations were to be removed in the future, the essential form and integrity of the buildings would be unimpaired.
  - b. The new design should not use the same wall plane, roof line, or cornice line of the existing structure.

## Chapter VI – Public Design and Improvements

### A. Introduction

Public spaces define the spatial organization of the City, forming the basis for social, cultural, and economic interaction. The Downtown Pedestrian Mall is the centerpiece of the community. Charlottesville's historic parks, trails, boulevards, cemeteries, playgrounds, and other open spaces help balance the desired urban density and promote healthy living and quality of life. Public spaces accommodate multiple functions and provide social venues. The historic uses and organization of public spaces represent a timeline of cultural practices and values of the community. Significant features should be identified and respected when changes are proposed. New public spaces and improvements should reflect contemporary design principles and values.

Charlottesville has a rich history of public improvements, which include public buildings, bridges, streetscape landscaping and lighting, street furniture, monuments, public art, fountains, and signage. Many of these improvements have been made within the historic districts, and there will be the opportunity to create additional such amenities in future years. All changes or improvements require BAR review and approval, and should be compatible with the general architectural features and character of an area or district. Repairs and maintenance should match original materials and design, and should be accomplished in a historically appropriate manner.

All public improvements should reflect the quality and attention to detail and craftsmanship of the overall historic districts' character.

#### B. Plazas, Parks & Open Spaces

1. Maintain existing spaces and important site features for continued public use consistent with the original design intent,
2. Maintain significant elements in a historic landscape: grave markers, structures, landforms, landscaping, circulation patterns, boundaries, and site walls.
3. Design new spaces to reinforce streetscape and pedestrian goals for the district. These areas offer the opportunity to provide visual focal points and public gathering spaces for the districts.
4. New landscaping should be historically and regionally appropriate, indigenous when possible, and scaled for the proposed location and intended use.
5. Exterior furniture and site accessories should be compatible with the overall character of the park or open space.
6. Repairs and maintenance work should match original materials and design, and should be accomplished in a historically appropriate manner.
7. Avoid demolishing historic buildings to create open spaces and parks.

#### C. Public Buildings and Structures

1. Public buildings should follow design guidelines for new construction.
2. New structures, including bridges, should reflect contemporary design principles.

#### D. Streets, Walks, & Curbs

1. Retain historic paving or curbing.
2. If any historic paving or curbing is uncovered in future public projects, consider reusing it or parts of it in the new project.
3. Make street paving consistent throughout districts.
4. When widening existing streets provide sidewalks, street trees, and other elements that maintain the street wall and emphasize the human scale.
5. Limit paved areas to streets, driveways and pedestrian areas.
6. Consider using some type of distinctive crosswalks at key intersections or crossings.
7. Avoid faux techniques or appearances in materials, such as stamped asphalt or concrete.

8. When sidewalks must be repaired, match adjacent materials in design, color, texture, and tooling.
9. Avoid variation in sidewalk and curb materials.
10. When sidewalks need replacement, use a paving unit, such as brick or concrete with a tooled or saw cut joint that relates to the scale of the districts.
11. Avoid excessive curb cuts for vehicular access across pedestrian ways.
12. Where curb cuts are necessary, they should be consistent with other curb cuts in the area
13. Do not block sidewalks with street furniture elements.
14. Remove obsolete signs and poles.

#### E. Street Trees & Plantings

1. Maintain existing plantings in public rights of way.
2. Replace damaged or missing street trees with appropriate species. New street trees should be planted in appropriate locations. Consult the City-approved plant list.
3. Install plantings in areas like medians, divider strips, and traffic islands.
4. Locate planters so that they do not block sidewalks.

#### F. Lighting

1. In pedestrian areas, use smaller-scaled light fixtures that do not create a glare.
2. Light fixtures can vary according to district or sub-area and can be in traditional or contemporary styles.
3. Provide adequate lighting at critical areas of pedestrian/vehicular conflict, such as parking lots, alleys, and crosswalks.
4. Limit the number of styles of light fixtures and light sources used in each district except in cases of varying sub-areas or distinctive areas, such as bridges.
5. Light color and intensity should be consistent throughout a general area or subarea of a
6. historic district. Use similar lamping (bulb type) and/or wattage to maintain a consistent quality of light.
7. Provide street lighting fixtures with flat lenses that are shielded and directed down to the site in order to reduce glare and prevent uplighting.

#### I. Public Signs

1. Maintain the coordinated design for a citywide gateway, directional, and informational public sign system.
2. Add a distinctive street sign system for historic districts.
3. Continue to install plaques or signs commemorating significant events, buildings, and individuals in the districts.
4. Avoid placing sign posts in locations where they can interfere with the opening of vehicle doors.
5. Preserve existing historic plaques located in the district.
6. New plaques should be discreetly located and should not obscure architectural elements.

#### K. Parking Facilities

1. Ensure that the design of any new parking structure follows the design guidelines in *Chapter 3* for new multi-lot buildings and street-level design.
2. The street-level design of parking garage facilities should engage pedestrians through the use of storefronts, display windows or other visual features.
3. Avoid demolishing historic buildings to construct new parking facilities.
4. Locate vehicular exits and entrances to minimize their impact on the primary street on which they are located.
5. Parking at the ground level should not be visible from the street.



6. Reduce the scale of the openings by providing separate entrances and exits.
7. Consider the impact of interior and roof lighting.

## **APPENDIX**

### **Prior BAR Reviews**

350 Park Street

February 2003 – Prelim discussion. Temporary sally port and ADA ramp.

March 2003 - Prelim discussion. Permanent ADA ramp.

December 15, 2020 – BAR approved CoA for selective demolition of the Levy Building hyphen and east annex

Having considered the standards set forth within the City Code, including City Design Guidelines for Demolitions, I move to find that the proposed demolition satisfies the BAR's criteria and is compatible with this property and other properties in the North Downtown ADC District, and that the BAR approves the application as submitted, with the following conditions:

- that the east wall of the Levy Building is substantially protected from damage;
- that the BAR recommends archaeological work within the footprint of the proposed demolition area of the hyphen and annex;
- that the BAR encourages and supports archaeological planning as part of the schematic design development for the larger project site;
- that the demolition includes the concrete steps (formerly to a house) along High Street.  
(Zehmer, Lewis second. Motion passed 8-0.)

# LANDMARK



# SURVEY

## IDENTIFICATION

Street Address: 350 Park Street  
Map and Parcel: 53-109  
Census Tract & Block: 1-103  
Present Owner: Town Hall-Levy Opera House Found.,  
Address: Inc.  
Present Use:  
Original Owner: Charlottesville Town Hall Co.  
Original Use: Town Hall

## BASE DATA

Historic Name: The Levy Opera House  
Date/Period: 1851-2  
Style: Greek Revival  
Height to Cornice: 48  
Height in Stories: 3  
Present Zoning: B-1  
Land Area (sq.ft.): 56 x 112  
Assessed Value (land + imp.): 12,300 + 13,890 = 26,190

## ARCHITECTURAL DESCRIPTION

The Levy Opera House was the first building in Charlottesville to be designed with pilasters as the dominant architectural feature of the facade. The influence of this device was great. The Hughes House (c. 1853), Lyons Court (1858) and the Abell-Gleason House (1859) are a few examples of the "Pilastered Style" fashioned after the Levy Opera House. The pilasters of the Opera House are stuccoed and painted to make them outstanding and to create a portico effect. The four pilasters support a Tuscan entablature and a hipped roof which replaced the original Classical pediment. The Flemish bond brickwork is among the latest examples in the city. As a town hall, the town hall had a level floor, a stage with two curtains (one with advertising), fly decks, and benches for seats.

## HISTORICAL DESCRIPTION

On July 9, 1851, the Trustees of the Charlottesville Town Hall Company, headed by Valentine W. Southall, purchased the lot from Samuel Leitch for \$750 "for the purpose of building a town hall". In December, 1852, a notice was placed in the local paper by H. Benson that the newly completed town hall would be available to rent for lectures, concerts, and thespian productions. The building was sold in 1887 and opened in March, 1888, as an opera house. One year later Jefferson Monroe Levy of Monticello gained title to the property. He sold it in 1914 to E. G. Haden who turned the building into apartments. Deed references: ACDB 50-143, City DB 2-32, 27-46, 34-302, 37-218, 73-158, 116-341, 337-5, 337-574.



## CONDITIONS

Poor

## SOURCES

City/County Records  
Alexander, Recollections, p.37.  
Margaret F. Clark



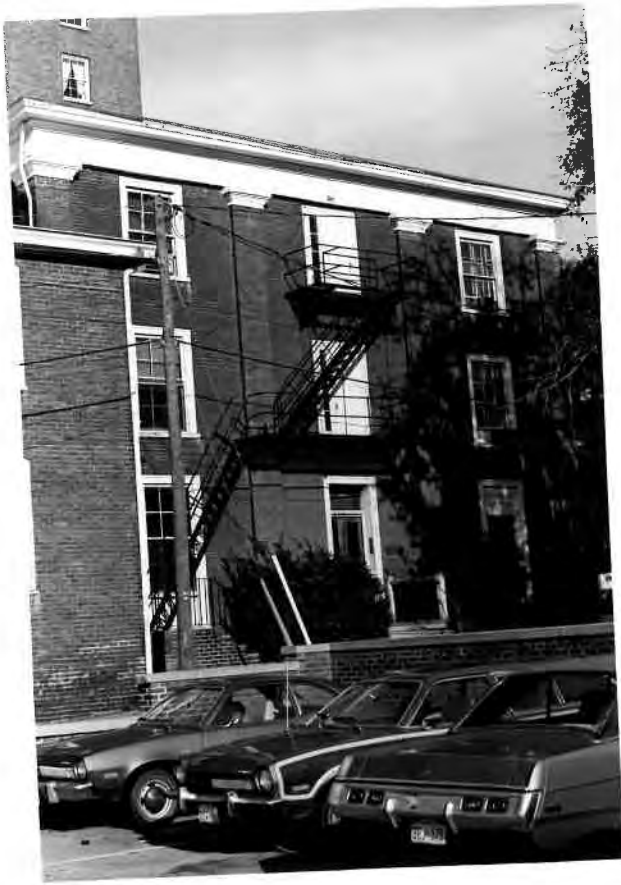



# Board of Architectural Review (BAR) Certificate of Appropriateness

Please Return To: City of Charlottesville  
Department of Neighborhood Development Services  
P.O. Box 911, City Hall  
Charlottesville, Virginia 22902  
Telephone (434) 970-3130

Please submit ~~ten (10) hard copies~~ and one (1) digital copy of application form and all attachments.  
Please include application fee as follows: New construction project \$375; Demolition of a contributing structure \$375;  
Appeal of BAR decision \$125; Additions and other projects requiring BAR approval \$125; Administrative approval \$100.  
Make checks payable to the City of Charlottesville. No fee: City/County-owned property  
The BAR meets the third Tuesday of the month.  
Deadline for submittals is Tuesday 3 weeks prior to next BAR meeting by 3:30 p.m.

Owner Name	City of Charlottesville / County of Albemarle	Applicant Name	Eric Amtmann (DGP Architects)
Project Name/Description	Albemarle County & Charlottesville City General District Courts Complex	Parcel Number	530109000, 530108000
Project Property Address	350 Park Street, 0 Park Street		

### Applicant Information

Address: DGP Architects  
206 Fifth Street NE, Charlottesville, VA 22902  
 Email: eamtmann@dgparchitects.com  
 Phone: (W) (434) 977-4480 (C) (434) 882-1767

### Property Owner Information (if not applicant)

Address: City of Charlottesville / County of Albemarle  
PO Box 911, Charlottesville, VA 22902  
 Email: \_\_\_\_\_  
 Phone: (W) \_\_\_\_\_ (C) \_\_\_\_\_

Do you intend to apply for Federal or State Tax Credits for this project? N/A

### Signature of Applicant

I hereby attest that the information I have provided is, to the best of my knowledge, correct.

*Eric Amtmann* 2021.06.29  
 Signature Date  
Eric Amtmann 2021.06.29  
 Print Name Date

### Property Owner Permission (if not applicant)

I have read this application and hereby give my consent to its submission.

*Blake Abplanalp* 2021.06.29  
 Signature Date  
Blake Abplanalp 2021.06.29  
 Print Name Date

**Description of Proposed Work (attach separate narrative if necessary):** Construction of new General District Courts facility, renovations to the Levy Building for the County Commonwealth's Attorney, and associated sitework and landscaping. The applicant will introduce the project intent and design to the BAR for discussion and feedback, then request a deferral with no BAR action requested at this meeting.

### **List All Attachments (see reverse side for submittal requirements):**

Albemarle County & Charlottesville City General District Courts Complex BAR Review, 40 pages, dated 2021.06.29

<b>For Office Use Only</b>	Approved/Disapproved by: _____
Received by: _____	Date: _____
Fee paid: _____ Cash/Ck. # _____	Conditions of approval: _____
Date Received: _____	_____
<i>Revised 2016</i>	

# Albemarle County & Charlottesville City General District Courts Complex

City of Charlottesville  
Board of Architectural Review

June 29, 2021



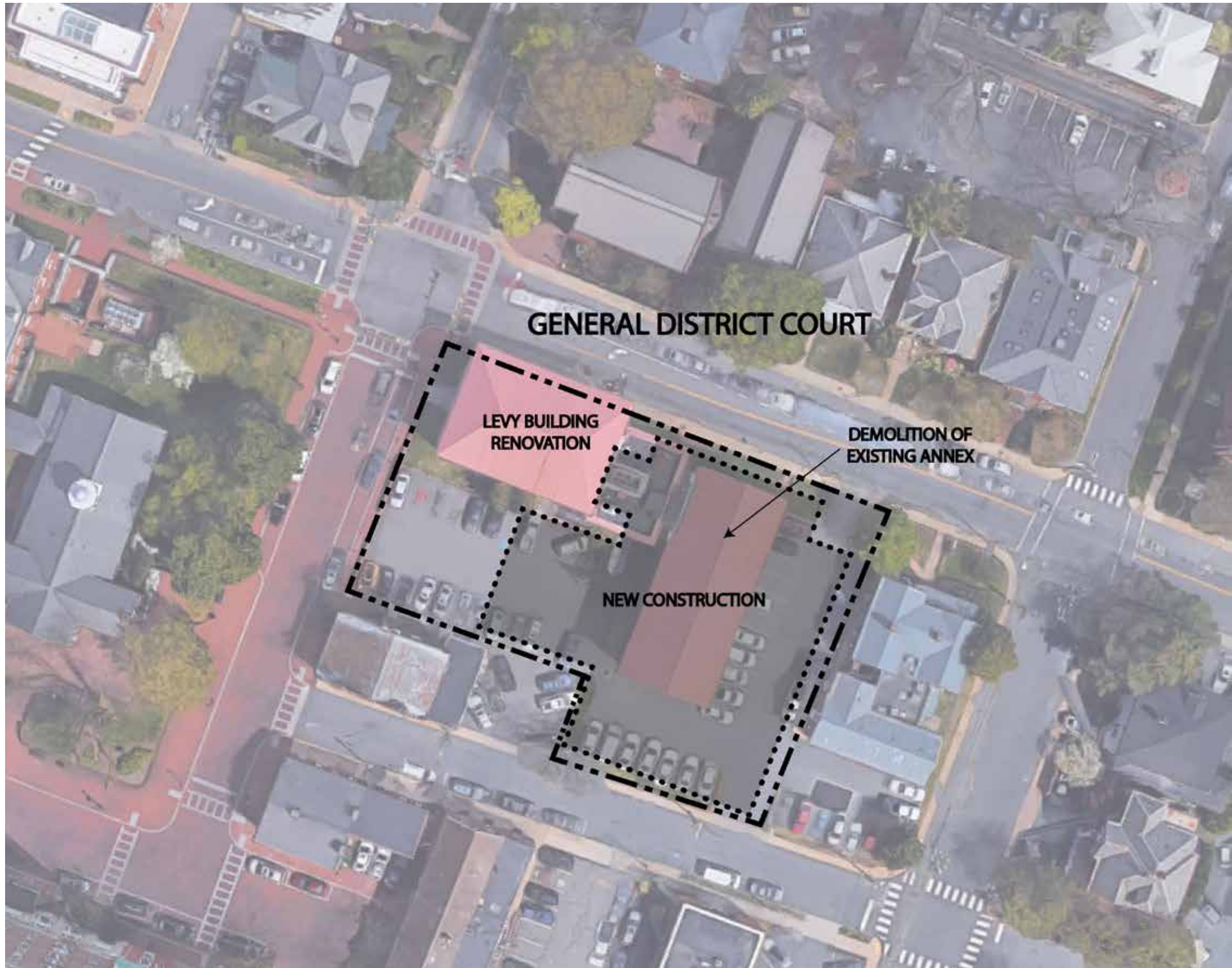

# HISTORY & CONTEXT





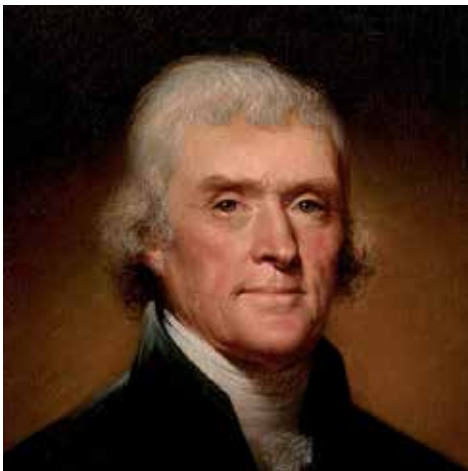

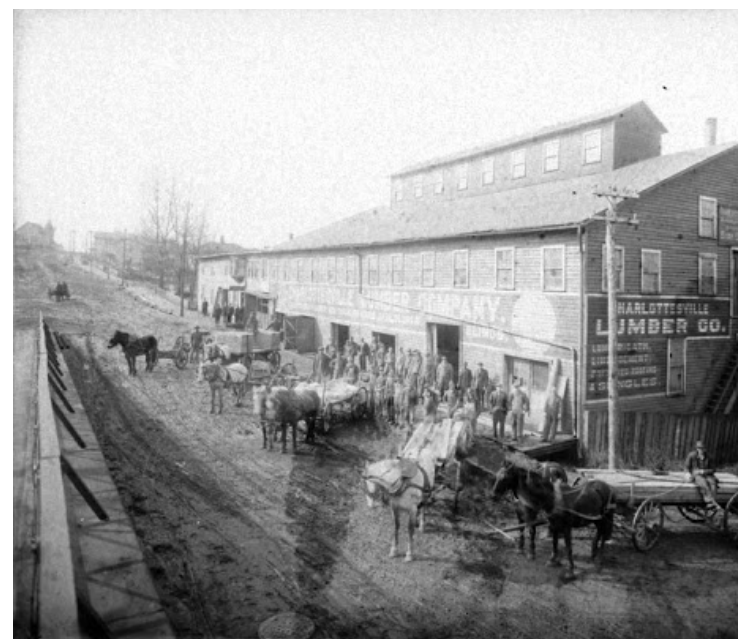
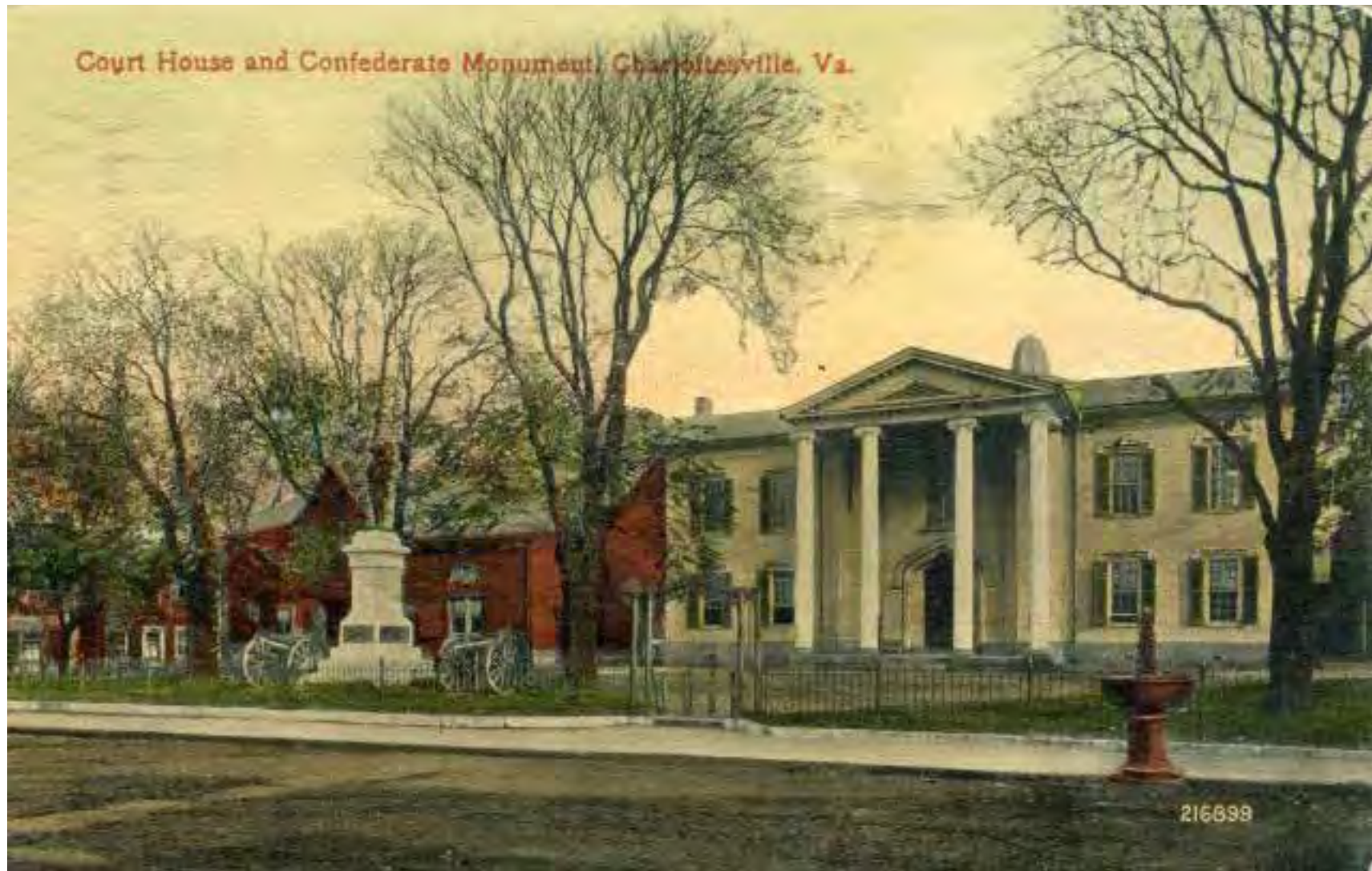



# SITE CONTEXT





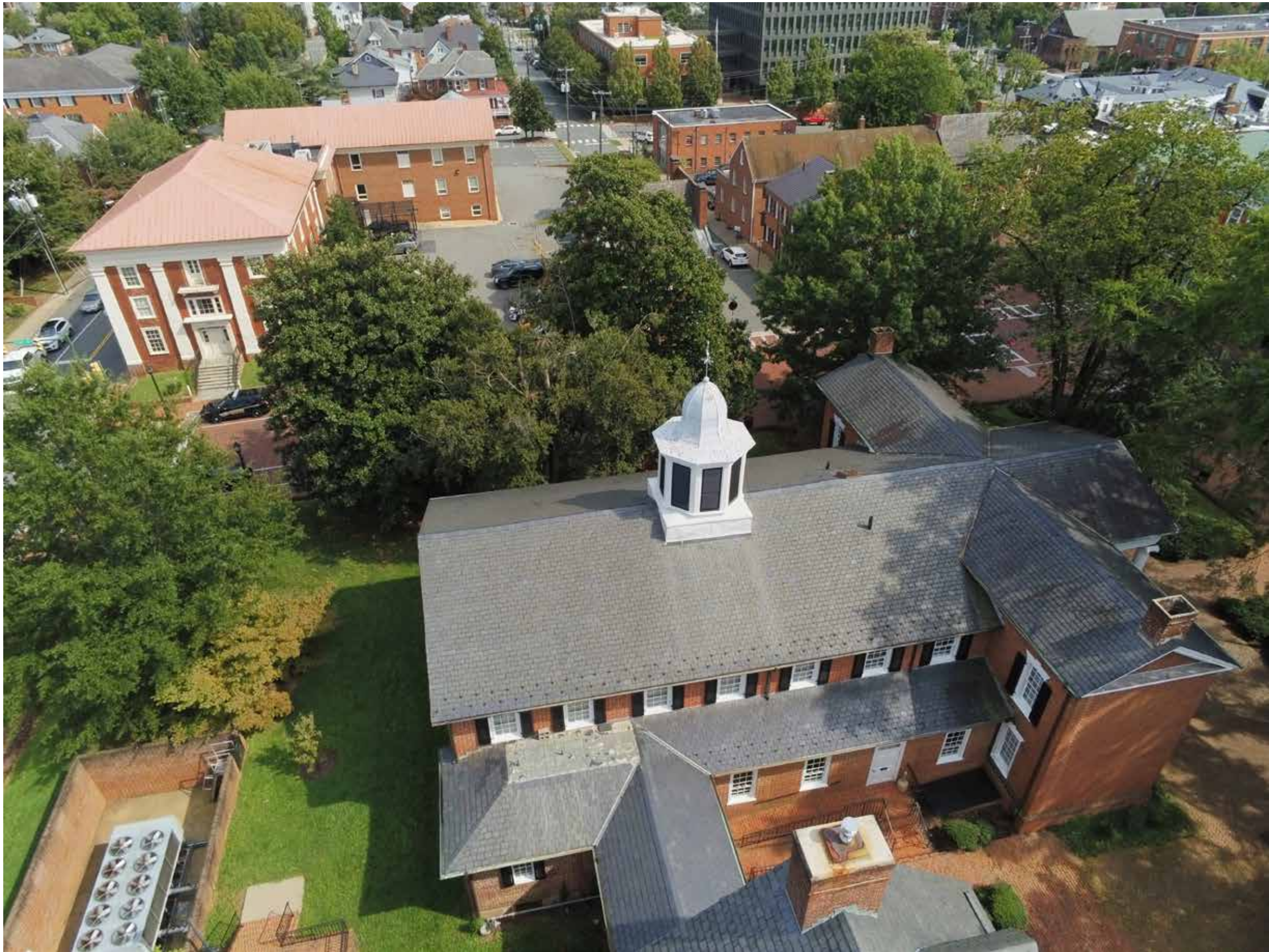



**1935 CIRCUIT COURT BUILDING ANNEX**



**1803 HISTORIC CIRCUIT COURT BUILDING**



**1851 LEVY BUILDING**









# SITE ANALYSIS





**URBAN EDGE**



**VIEWS TO SITE**

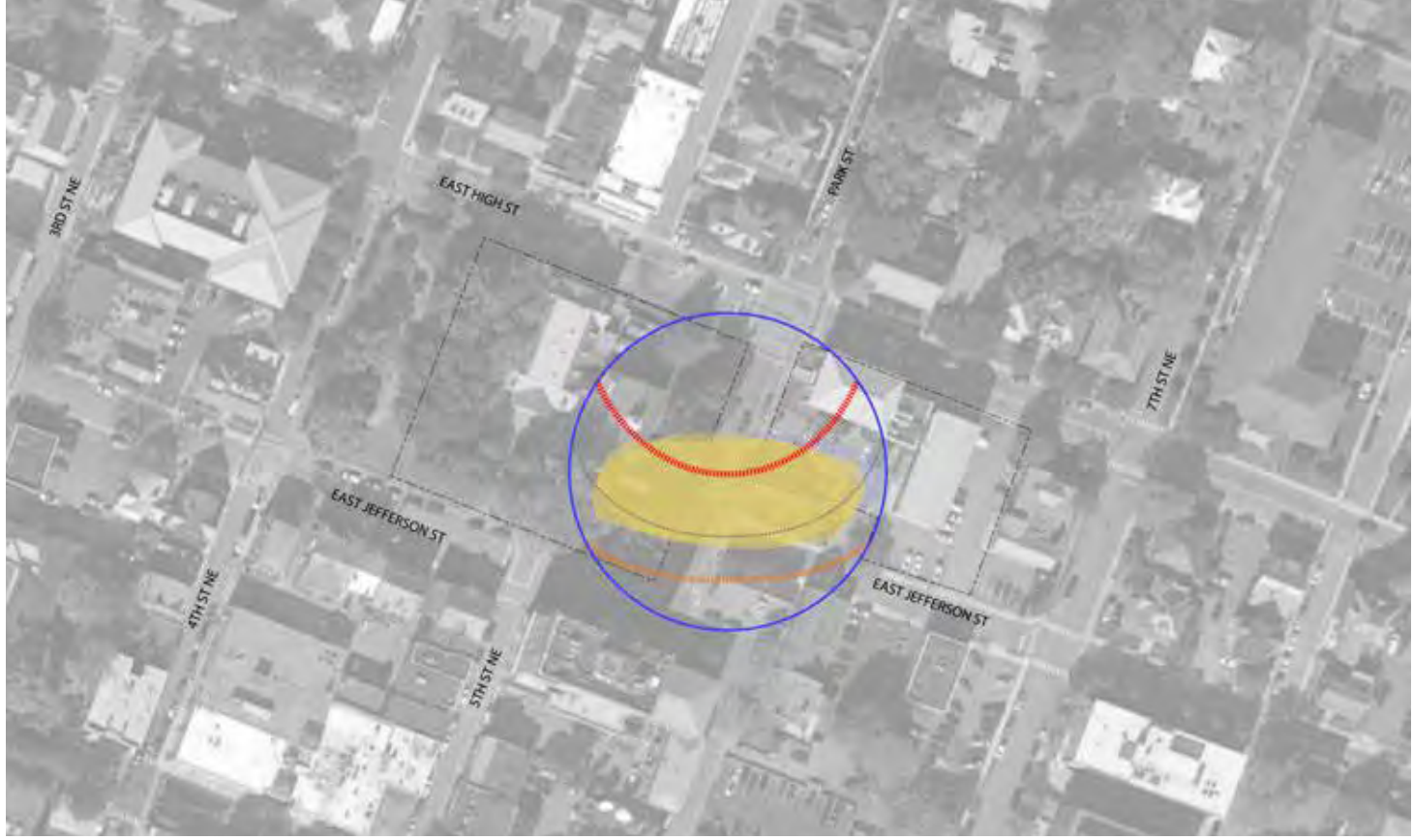

**SOLAR ORIENTATION**



**SITE TOPOGRAPHY**



# EAST SITE- BUILDING DESIGN



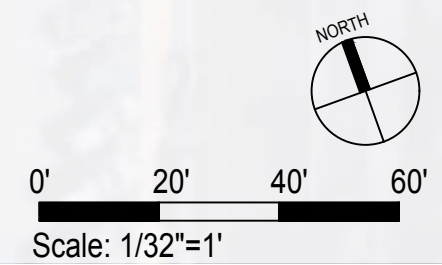
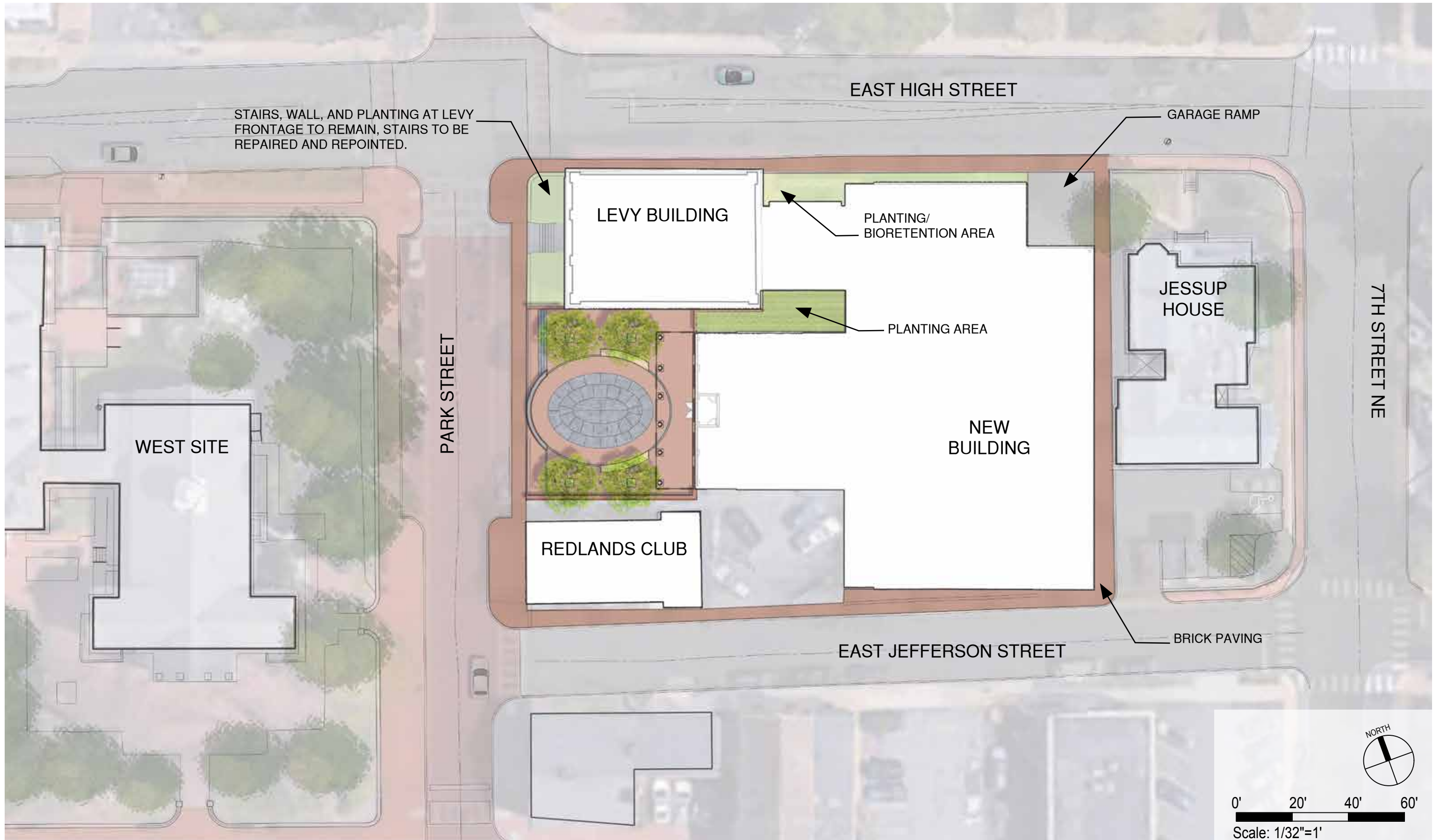

EAST HIGH STREET

PARK STREET

7TH ST NE

LEVY BUILDING

GARAGE RAMP BELOW

JESSUP HOUSE

REDLANDS CLUB

PARKING AREA MODIFIED (BY OTHERS)

E. JEFFERSON STREET



PLAN

TRUE

0 10 20



FENTRESS ARCHITECTS

FIRST FLOOR  
EAST SITE

June 29, 2021  
Albemarle County & Charlottesville City  
General District Courts Complex  
Charlottesville, VA

EAST HIGH STREET

PARK STREET

7TH ST NE

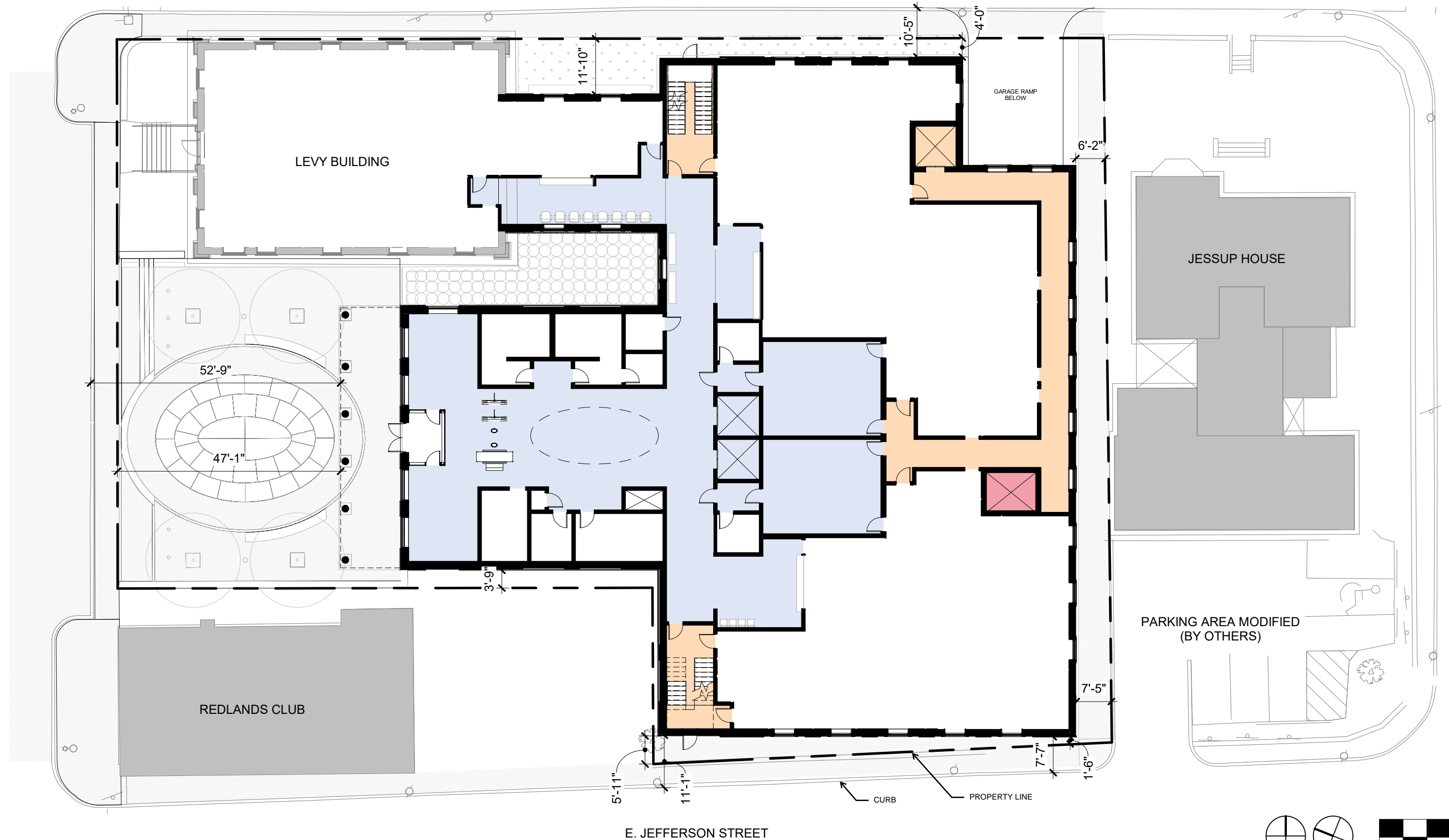

E. JEFFERSON STREET

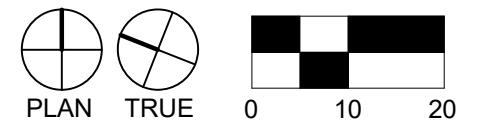

**FENTRESS** ARCHITECTS

**FIRST FLOOR (UPDATED)**  
EAST SITE

July 20, 2021  
Albemarle County & Charlottesville City  
General District Courts Complex  
Charlottesville, VA

EAST HIGH STREET

PARK STREET

7TH ST NE

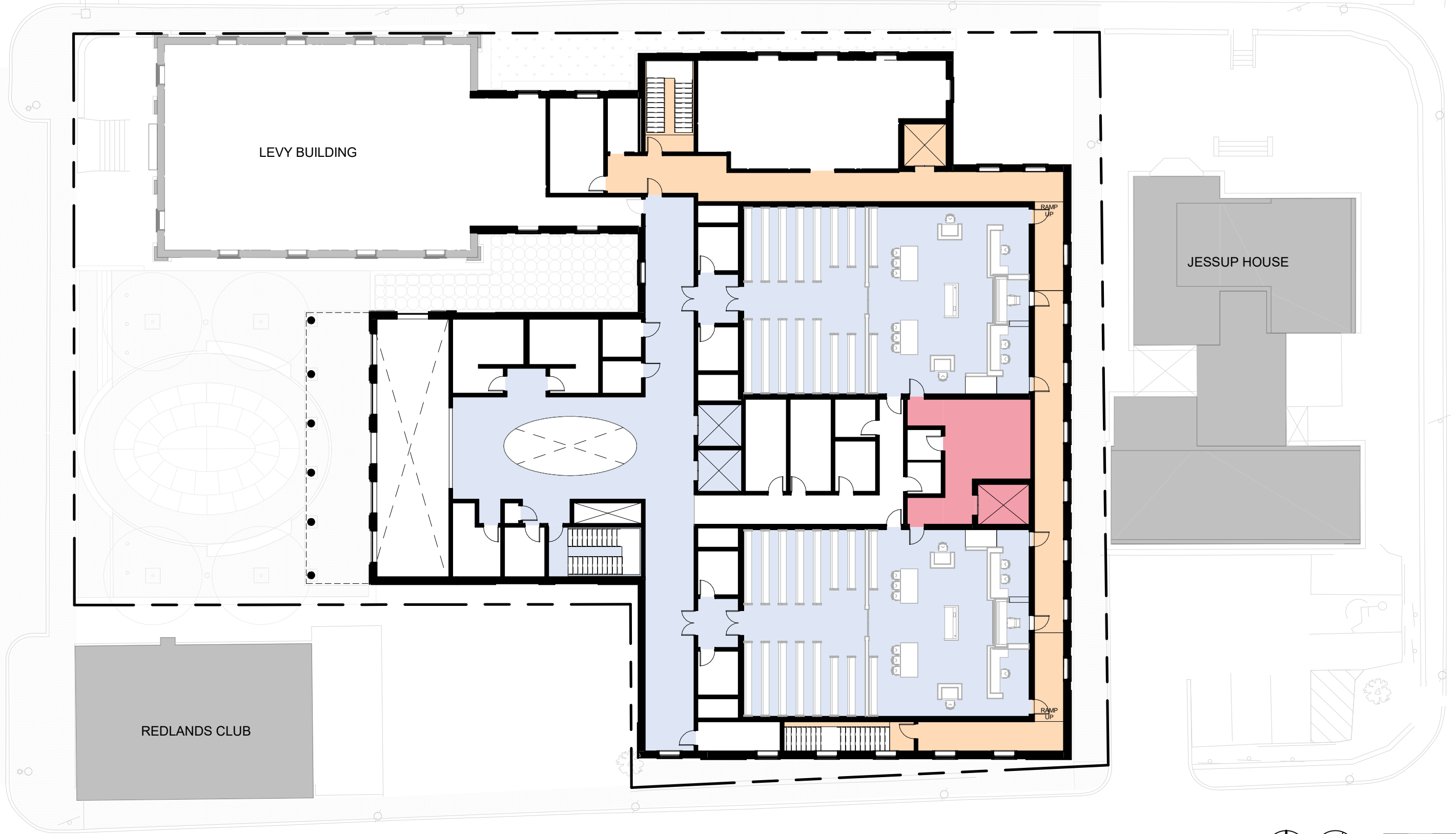

LEVY BUILDING

JESSUP HOUSE

REDLANDS CLUB

RAMP UP

RAMP UP

E. JEFFERSON STREET

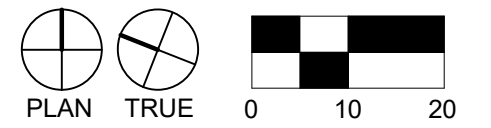

**FENTRESS** | ARCHITECTS

**SECOND FLOOR**  
EAST SITE

June 29, 2021  
Albemarle County & Charlottesville City  
General District Courts Complex  
Charlottesville, VA



EAST HIGH STREET

PARK STREET

LEVY BUILDING

JESSUP HOUSE

7TH ST NE

REDLANDS CLUB

E. JEFFERSON STREET

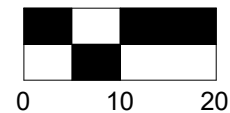
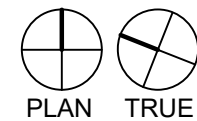

FENTRESS ARCHITECTS

SECOND FLOOR (UPDATED)  
EAST SITE

July 20, 2021  
Albemarle County & Charlottesville City  
General District Courts Complex  
Charlottesville, VA

EAST HIGH STREET

PARK STREET

7TH ST NE

LEVY BUILDING

JESSUP HOUSE

REDLANDS CLUB

MECHANICAL PENTHOUSE  
SCREEN WALL

E. JEFFERSON STREET

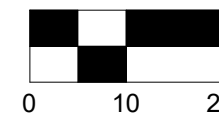
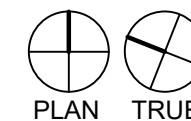

**FENTRESS** | ARCHITECTS

**ROOF**  
EAST SITE

June 29, 2021  
Albemarle County & Charlottesville City  
General District Courts Complex  
Charlottesville, VA



**THE ROTUNDA - CHARLOTTESVILLE, VA**



**STATE CAPITOL - RICHMOND, VA**



**US COURTHOUSE - HUNTSVILLE, AL**



**CARRE D'ART - NIMES, FRANCE**



**US COURTHOUSE - SPRINGFIELD, MA**



**US COURTHOUSE - BAKERSFIELD, CA**



**FENTRESS** | ARCHITECTS

**PORTICO ARCHITECTURE**  
EAST SITE

June 29, 2021  
Albemarle County & Charlottesville City  
General District Courts Complex  
Charlottesville, VA





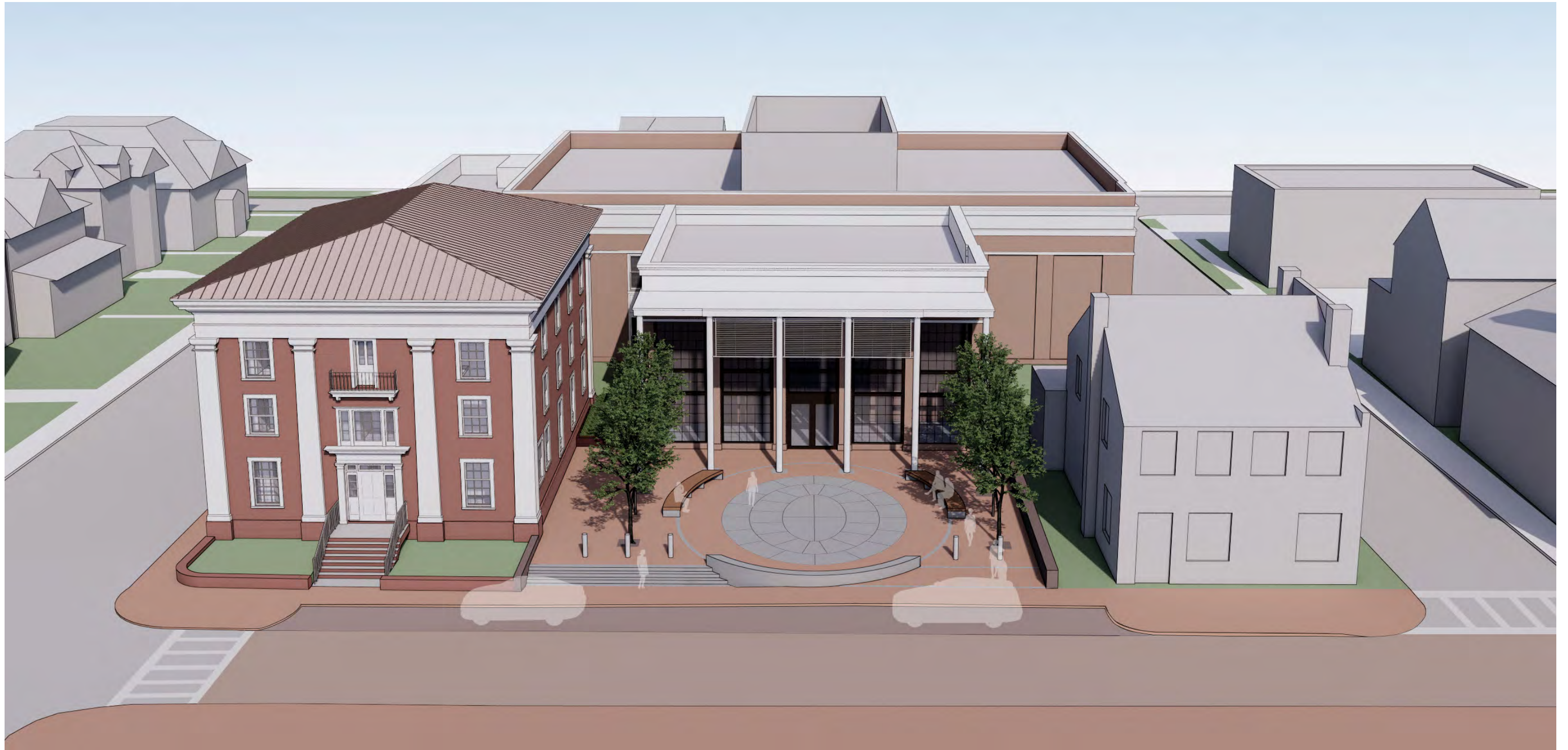

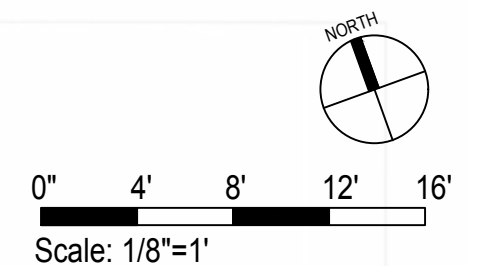
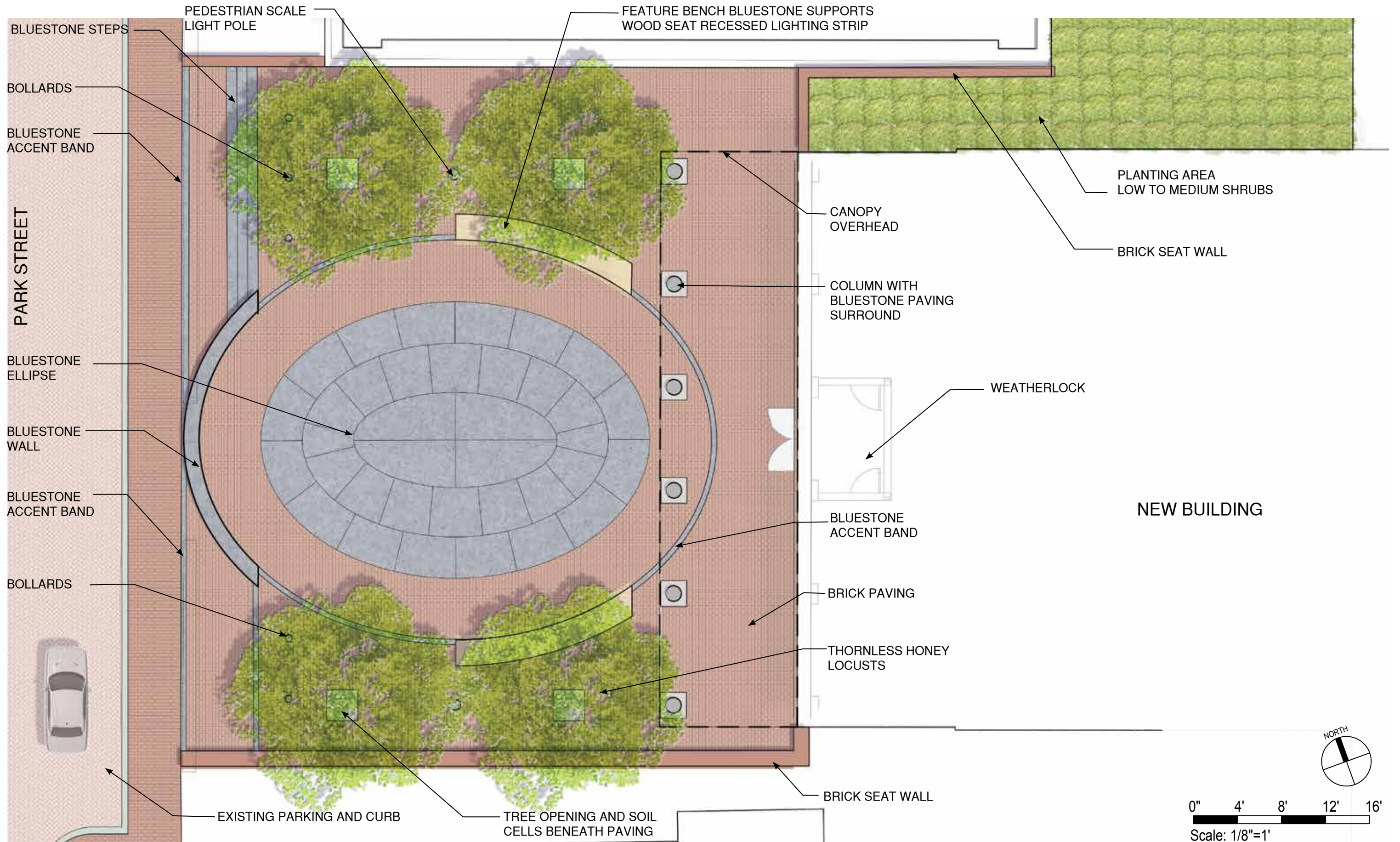

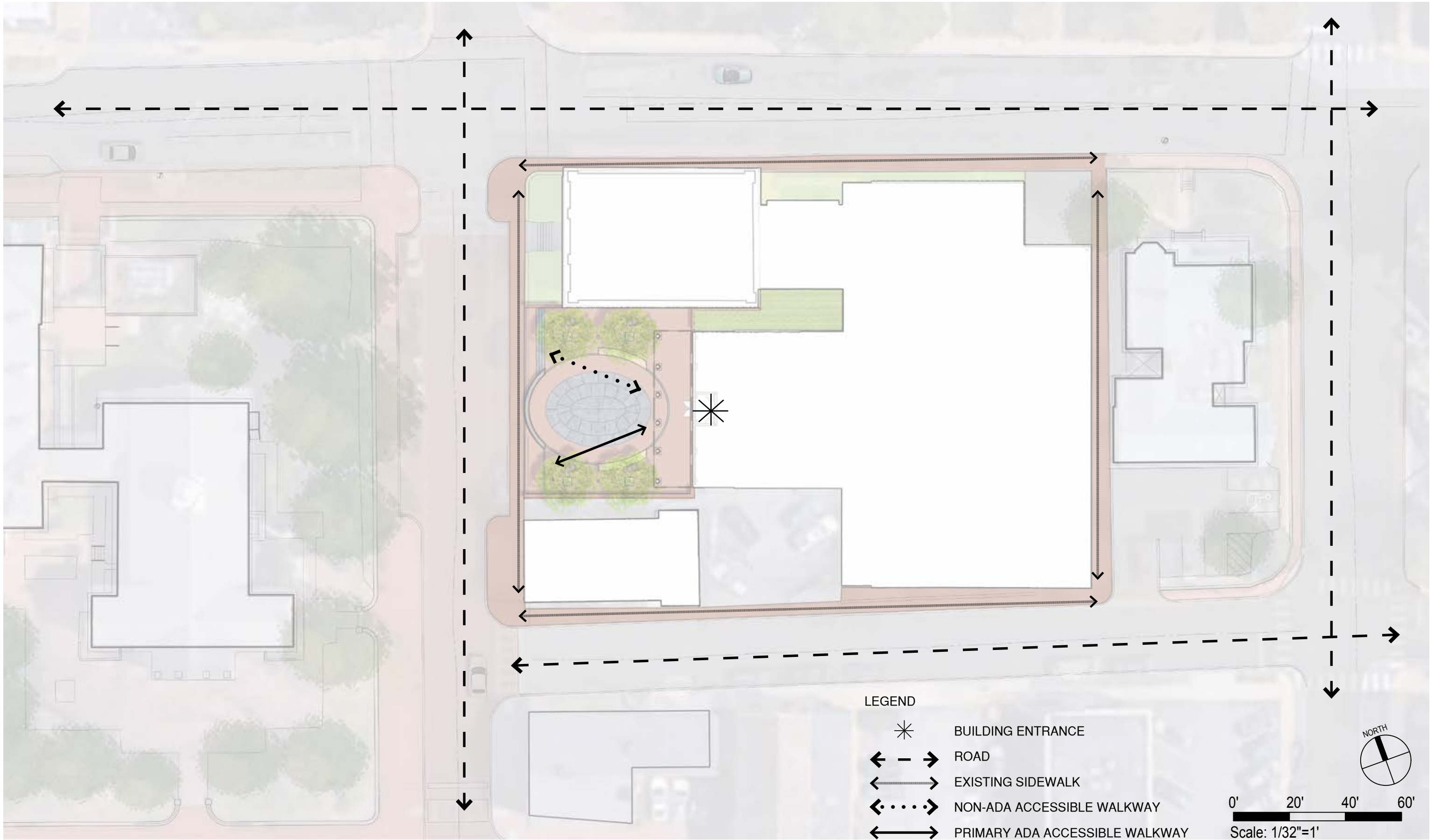

LEGEND



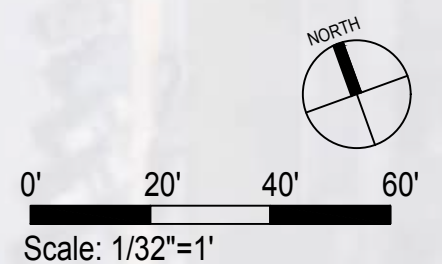

- ✱ BUILDING ENTRANCE
- ← - - - - -> ROAD
- ↔ EXISTING SIDEWALK
- ⋯ NON-ADA ACCESSIBLE WALKWAY
- ↔ PRIMARY ADA ACCESSIBLE WALKWAY

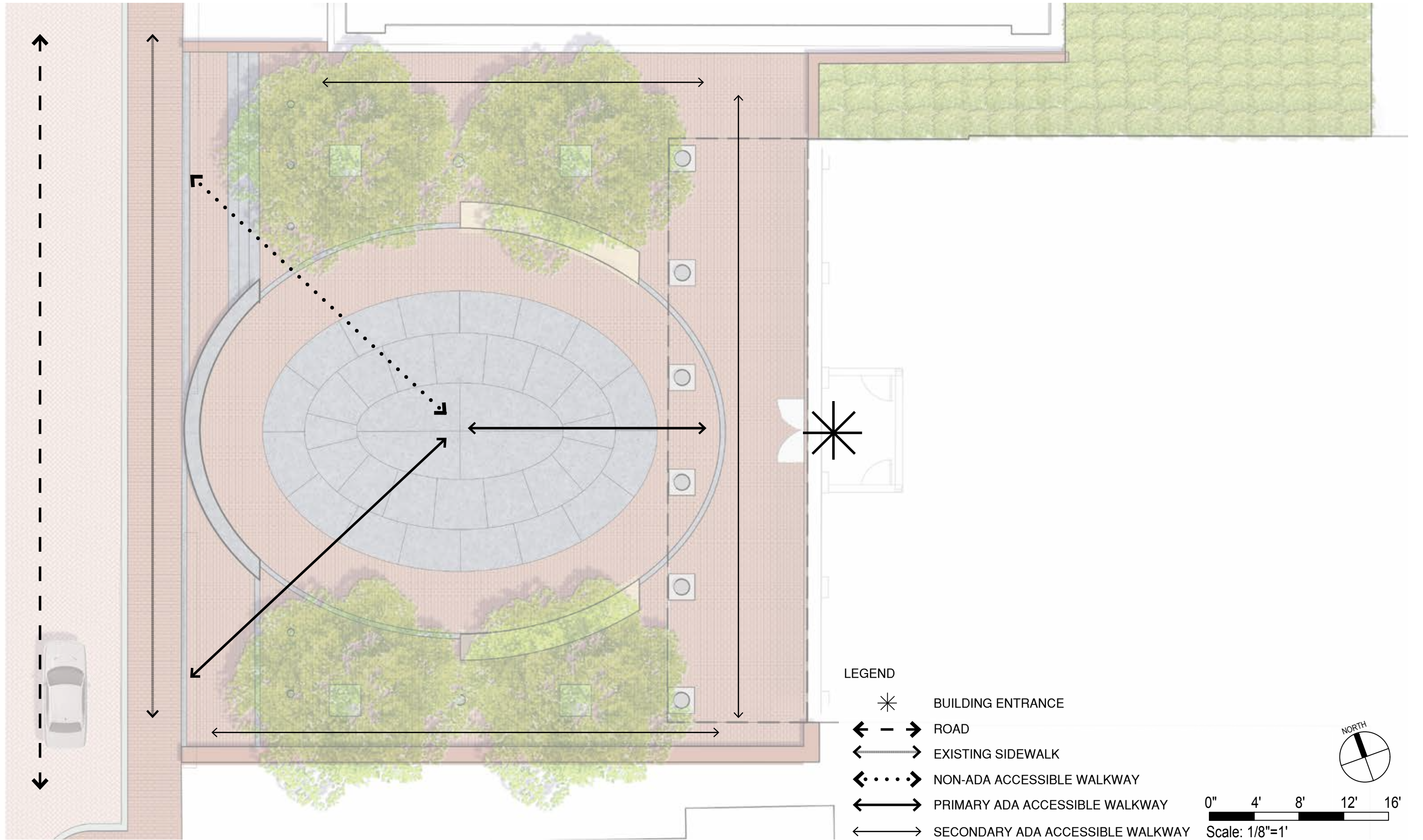



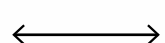

LEGEND

-  BUILDING ENTRANCE
-  ROAD
-  EXISTING SIDEWALK
-  NON-ADA ACCESSIBLE WALKWAY
-  PRIMARY ADA ACCESSIBLE WALKWAY
-  SECONDARY ADA ACCESSIBLE WALKWAY

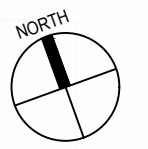
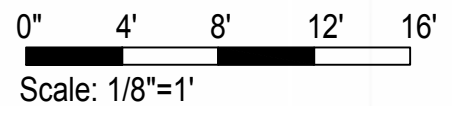

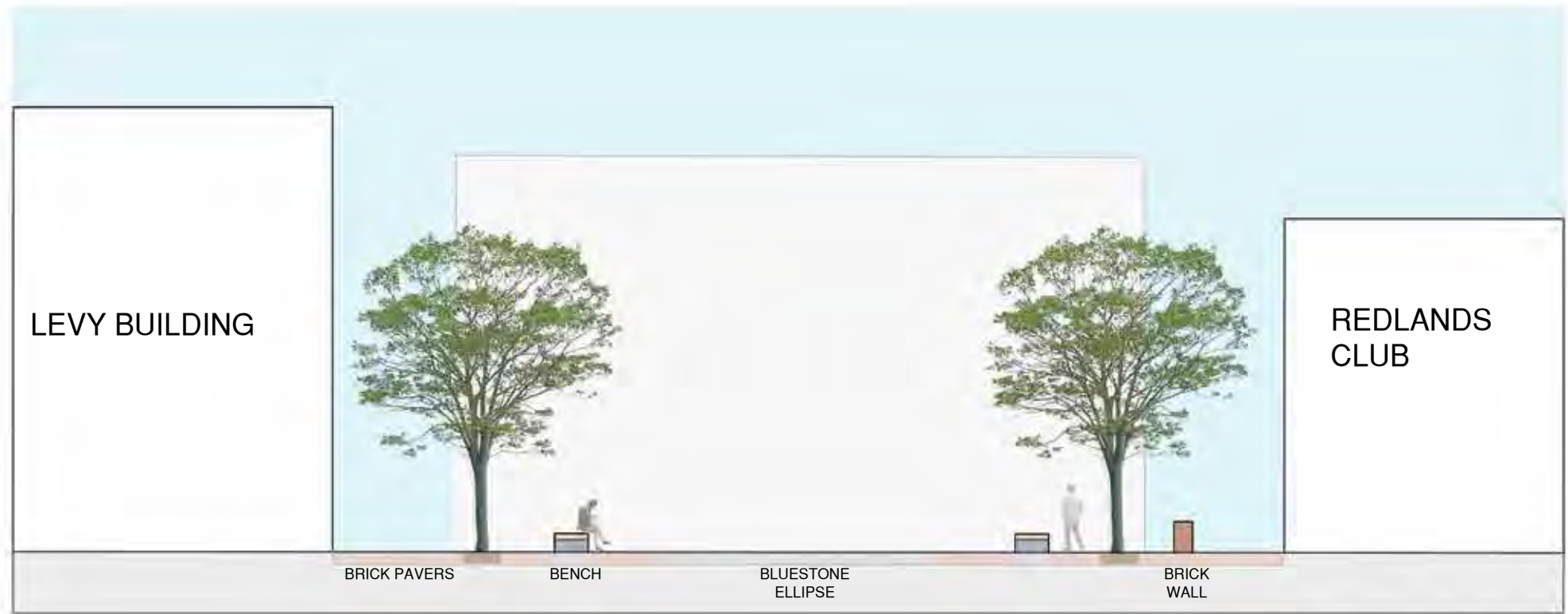

PLAZA SECTION: NORTH-SOUTH A-A'

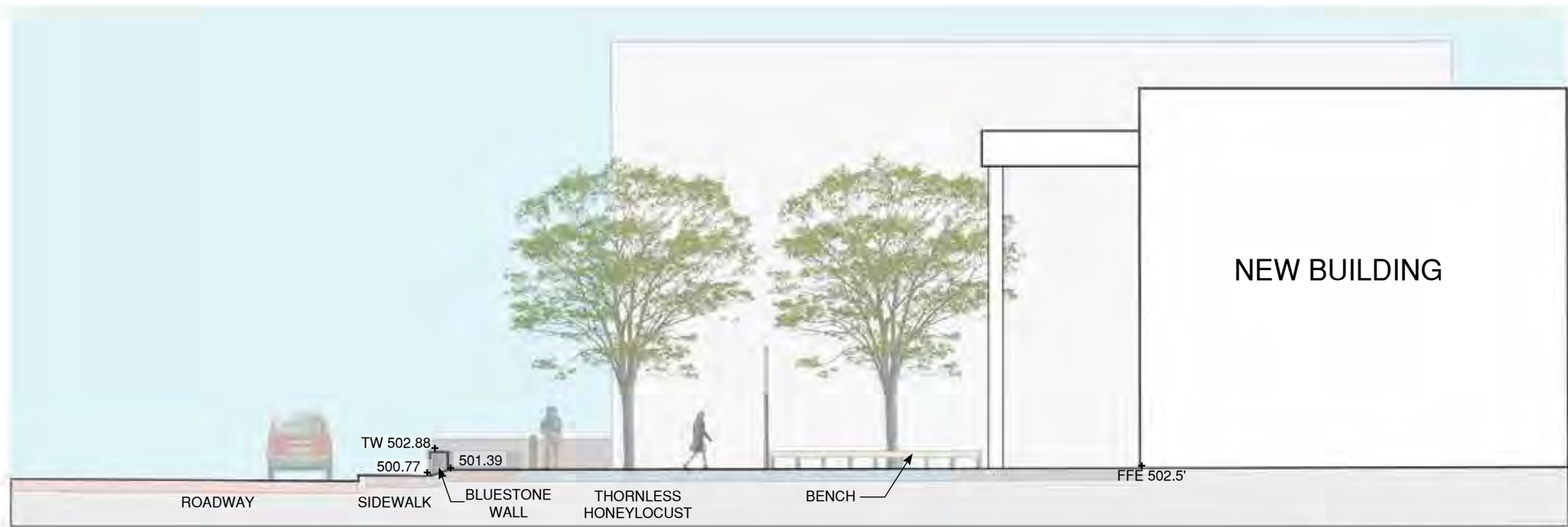
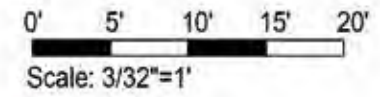

PLAZA SECTION: WEST-EAST B-B'

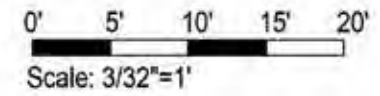

















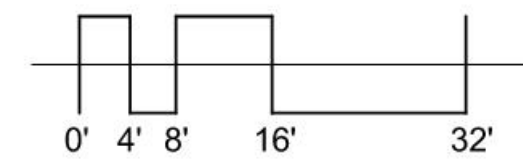





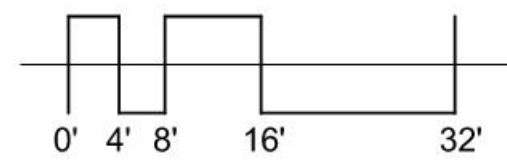
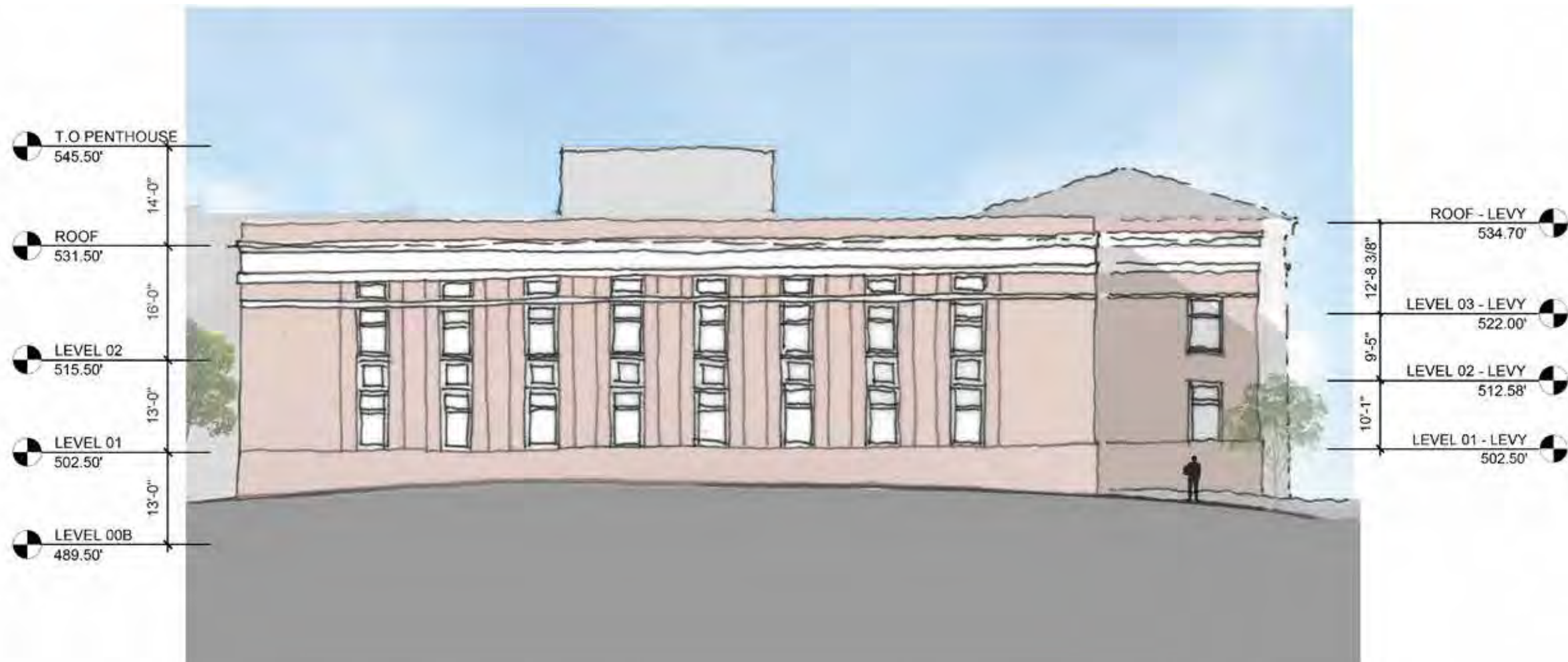

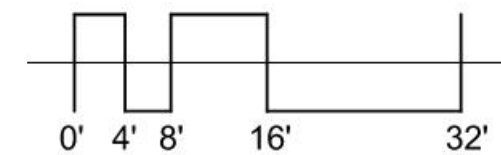









**LIMESTONE**



**BLUESTONE**

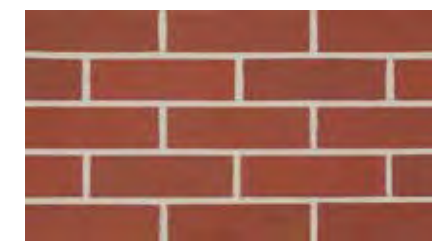

**Commodore Smooth**



**Medium Red Smooth**



**Modular 503-505**



**Colony Red Range**

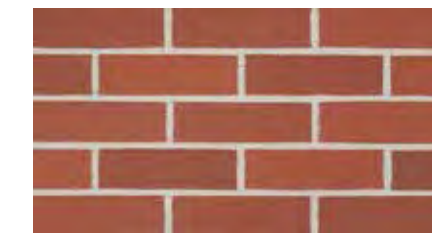

**Rubigo Red Smooth**



**Light Red Smooth**

**BRICK- EXTRUDED**



**BRONZE WINDOW FRAME**



**CONTEMPORARY LIGHT FIXTURE**



**CONTEMPORARY UNLIT BOLLARD**

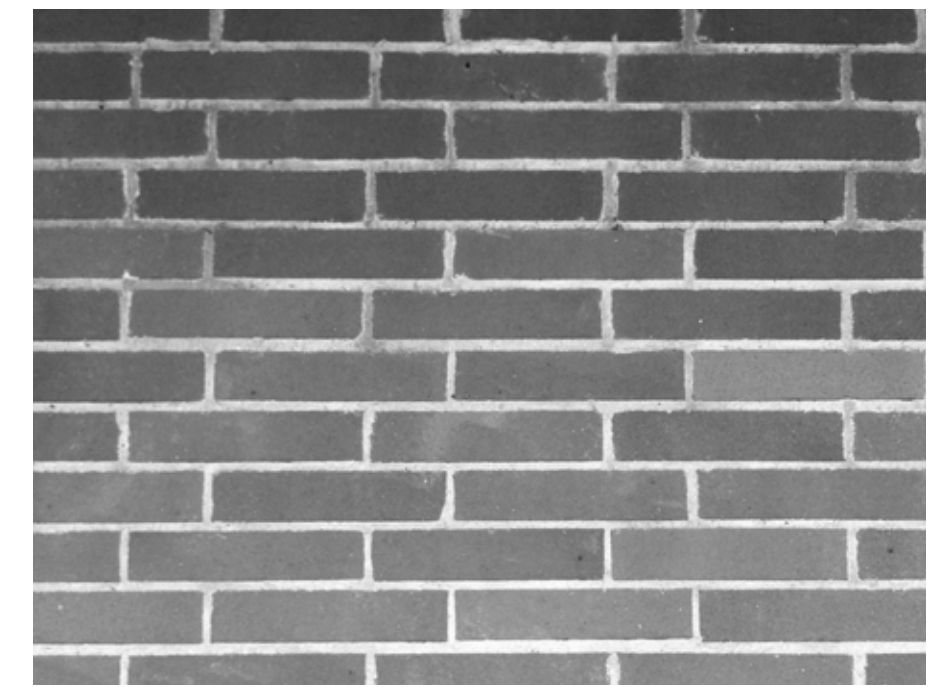

**NORMAN BRICK WITH 1/3 RUNNING BOND PATTERN**



**LIMESTONE**

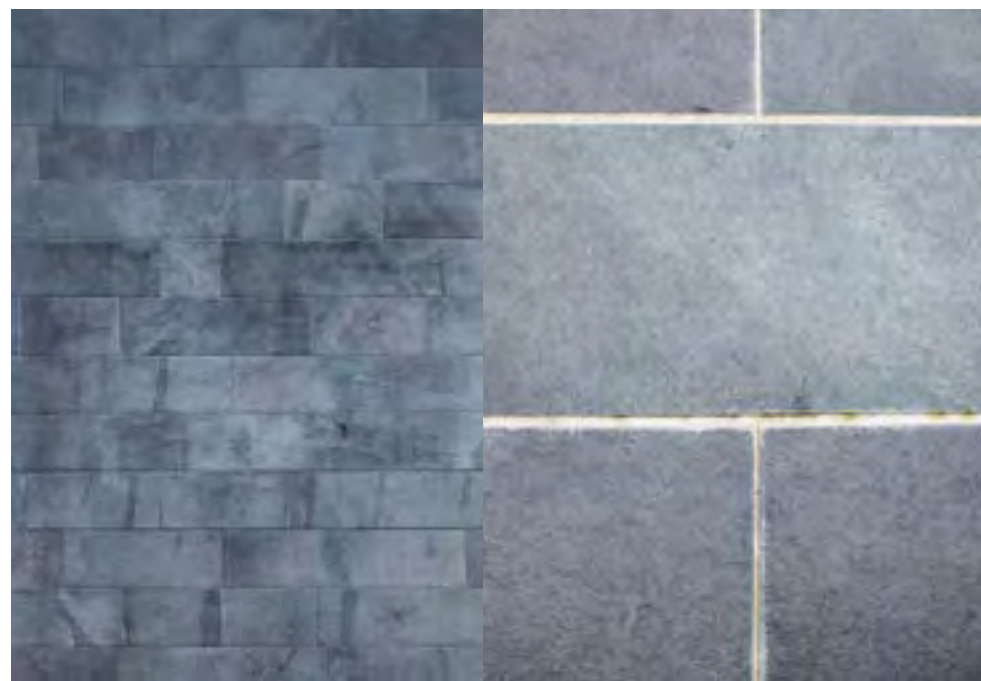

**BLUESTONE**



**BRICK- EXTRUDED**



**BRONZE WINDOW FRAME**



**CONTEMPORARY  
LIGHT FIXTURE**



**CONTEMPORARY  
UNLIT BOLLARD**

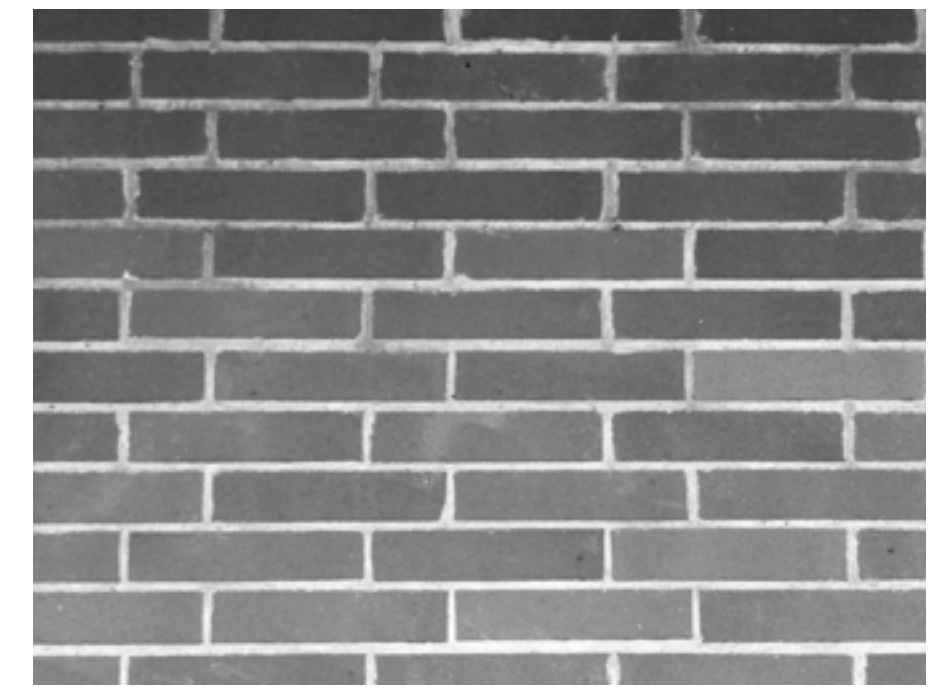

**NORMAN BRICK WITH  
1/3 RUNNING BOND PATTERN**





WOOD TOPPED BLUESTONE BENCH



UNDERLIT BENCH

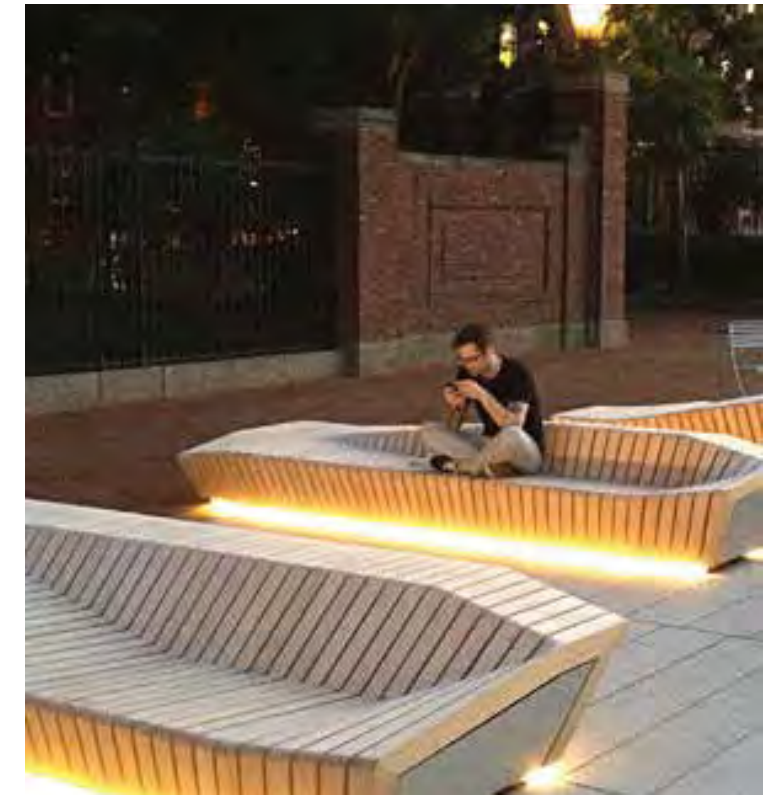

BLUESTONE PAVING



BLUESTONE PAVING AT COLUMN

BAR 16-11-01  
401 Cherry Avenue, TMP 290150000  
Owner: Gateway Terrace Partners, LLC  
Representative: Doug Stafford, Griffin-Stafford Hospitality  
Project: Repairs to stucco

Application components (please click each link to go directly to PDF page):

- [Staff Report](#)
- [2016 Staff Report for William Taylor Plaza CoA](#)
- [Conditions Photos](#)
- [Documentation and Specs](#)

**City of Charlottesville  
Board of Architectural Review  
Staff Summary  
July 20, 2021**



**Discussion of proposed stucco repairs**

William Taylor Plaza – Phase I

(Currently the Fairfield Inn & Suites by Marriott Charlottesville Downtown/University Area)  
401 Cherry Avenue



**Background**

In December 2015, the BAR approved the final CoA for Phase I of the William Taylor Plaza. (See the attached March 2016 staff report for a summary of the BAR’s actions.) That project, a proposed hotel, was completed in 2018. The project/hotel was sold in 2018 and again in 2019. Currently it is operated as The Fairfield Inn & Suites by Marriott, owned by Gateway Terrace Partners, LLC of Charlotte, NC, and managed by Griffin-Stafford Hospitality of Charlotte, NC.

**In early 2020, staff was contacted by Doug Stafford (Griffin-Stafford Hospitality) regarding delaminating and otherwise failing stucco on the building and requested guidance on how to proceed with repairs, such that the work would be acceptable to the BAR.** After some initial correspondence, the *circumstances of 2020* prevailed, and the matter placed on hold.

In March 2021, discussions with Mr. Stafford resumed and he presented a repair option, which staff circulated to the BAR. The following summarizing the BAR’s comments and questions, which I shared with Mr. Stafford:

- Have they established where the moisture is coming from?
  - What exactly is the existing condition?
  - They refer to a vapor barrier. That does not appear to be indicated in the drawing.
  - What is the spec for that vapor barrier? Is it a vapor retarder (i.e. is somewhat permeable) or is it in fact a vapor barrier (i.e. impermeable)?
  - Is there a drainage plane associated with the vapor barrier?
- Request the manufacturer’s specs & drawings for the proposed system – details as drawn are too generic.

In following up on the above with, it was agreed that the best path forward would be to present this BAR directly.

## Discussion

The areas to be repaired are all stucco walls shown on the elevations on sheets A-200 and A-201-- see the key in the lower, righthand corner. (Note: the clouded area on these sheets are not relevant. They are from modifications made in 2017, and not related to the stucco repair.)

Photographs show the existing conditions.

The proposed repairs will apply a Parex EIFS system over the existing hard coat stucco. The primary details are shown on sheet A-455, which references to the existing hard coat stucco system (Decoplast Decowall FRS) and details how the Parex EIFS system will be installed (the water resistive and air barrier coating installed over the existing stucco). A-455 also illustrates the details at the various components—door and window trim and sills, roof parapet, etc.

### Also provided for reference:

- Information on the existing Decoplast Decowall FRS system. This includes the warranty document from the original developer (affirming that the Decowall FRS was used), and four spec sheets showing how the Decowall FRS is installed, including a water resistive barrier.
- Spec sheets for installing the Parex EIFS. (As noted in the spec sheets and Sheet A-455, the EIFS system will be drainable).

Aside from the material and methods proposed for the repairs, the repairs will result in a slight reveal at the perimeter of the existing windows, doors, and vents. As built, the stucco is flush with these components—see the images below. This modification is detailed on Sheet A-455. This new detail will be consistent on the building—and, in fact, be similar to the reveal condition at the brick wall segments. Staff suggests this is an acceptable detail modification.



The roof coping—at the stucco sections and where they intersect with the other finishes—will be modified to accommodate the additional layer of stucco.

At the interior corners where stucco abuts either brick or siding, appropriate expansion joints and materials will be used to waterproof those locations.

The existing horizontal and vertical joints in the stucco will be replicated with the new surface; however, the new material will cover the existing joints, with the new joints only in that new layer of stucco, and not extending into the old.

The Design Guidelines *recommend* against the use of EIFS; however, its use has been approved for recent projects. (1532–1536 Virginia Avenue, for example.) The BAR should discuss if the proposed Parex EIFS system is acceptable and, if necessary, request additional information about it.

### **Suggested Action**

This is a discussion only, with the owners and property manager seeking BAR guidance on repairing the existing stucco. This is not a CoA request and no formal action is required. The BAR may express that guidance by consensus, straw poll or even by motion and vote; however, such action will not constitute a CoA, nor modify a prior CoA, as defined by the City Code under *Historical Preservation and Architectural Design Control Overlay Districts*.

Staff suggests that the proposed repairs, if acceptable to the BAR, fall generally within *routine repair and maintenance*, which does not require a CoA and provides some flexibility for repairs that do not significantly alter a structure. Given the age and contemporary design of this building, staff suggest the resulting physical changes are minor, consistent with the design guidelines, and can be allowed without formal action. (For example, the BAR did not require formal approval for the modified LED lighting at The Standard.)

However, if the BAR feels a formal approval is necessary, staff can work with the owners and property manager to prepare a CoA application and submittal; however, staff recommends that the BAR first indicate they are amenable to the proposed repairs and offer clear guidance on any additional information that should be provided.

### **Criteria, Standards, and Guidelines**

Note: This is not a CoA request; however, guidance from the BAR must still be consistent with the review standards and design guidelines applicable to any project within an ADC District.

### **Review Criteria Generally**

Sec. 34-284(b) of the City Code states that, in considering a particular application the BAR shall approve the application unless it finds:

- 1) That the proposal does not meet specific standards set forth within this division or applicable provisions of the Design Guidelines established by the board pursuant to Sec. 34-288(6); and
- 2) The proposal is incompatible with the historic, cultural or architectural character of the district in which the property is located or the protected property that is the subject of the application.

### **Pertinent Standards for Review of Construction and Alterations include:**

- 1) Whether the material, texture, color, height, scale, mass and placement of the proposed addition, modification or construction are visually and architecturally compatible with the site and the applicable design control district;
- 2) The harmony of the proposed change in terms of overall proportion and the size and placement of entrances, windows, awnings, exterior stairs and signs;
- 3) The Secretary of the Interior Standards for Rehabilitation set forth within the Code of Federal Regulations (36 C.F.R. §67.7(b)), as may be relevant;
- 4) The effect of the proposed change on the historic district neighborhood;

- 5) The impact of the proposed change on other protected features on the property, such as gardens, landscaping, fences, walls and walks;
- 6) Whether the proposed method of construction, renovation or restoration could have an adverse impact on the structure or site, or adjacent buildings or structures;
- 7) Any applicable provisions of the City's Design Guidelines.

### **Pertinent Design Guidelines for New Construction**

Note: While this is an existing building, the guidelines Rehabilitation are not applicable to this condition, nor helpful under the circumstances.

#### **L. Foundation and Cornice**

1. Distinguish the foundation from the rest of the structure through the use of different materials, patterns, or textures.
2. Respect the height, contrast of materials, and textures of foundations on surrounding historic buildings.
3. If used, cornices should be in proportion to the rest of the building.
4. Wood or metal cornices are preferred. The use of fypon may be appropriate where the location is not immediately adjacent to pedestrians.

#### **M. Materials & Textures**

1. The selection of materials and textures for a new building should be compatible with and complementary to neighboring buildings.
2. In order to strengthen the traditional image of the residential areas of the historic districts, brick, stucco, and wood siding are the most appropriate materials for new buildings.
3. In commercial/office areas, brick is generally the most appropriate material for new structures. "Thin set" brick is not permitted. Stone is more commonly used for site walls than buildings.
4. Large-scale, multi-lot buildings, whose primary facades have been divided into different bays and planes to relate to existing neighboring buildings, can have varied materials, shades, and textures.
5. Synthetic siding and trim, including, vinyl and aluminum, are not historic cladding materials in the historic districts, and their use should be avoided.
6. Cementitious siding, such as HardiPlank boards and panels, are appropriate.
7. Concrete or metal panels may be appropriate.
8. Metal storefronts in clear or bronze are appropriate.
9. The use of Exterior Insulation and Finish Systems (EIFS) is discouraged but may be approved on items such as gables where it cannot be seen or damaged. It requires careful design of the location of control joints.
10. The use of fiberglass-reinforced plastic is discouraged. If used, it must be painted.
11. All exterior trim woodwork, decking and flooring must be painted, or may be stained solid if not visible from public right-of-way.



**City of Charlottesville**  
**Board of Architectural Review**  
**Staff Report**  
**April 19, 2016**  
(excerpts for July 20, 2021 discussion)



**Certificate of Appropriateness Application**

BAR 15-08-04

NW Corner of Ridge St. and Cherry Ave.

Tax Parcel 290145000-147000, 290149000-151000, 290157000

Charlie Armstrong, Owner/ Cherry Avenue Investments LLC, Applicant

Proposed new construction of a Marriot Hotel on the NW corner intersection of Cherry Avenue and Ridge Street – plaza facade design

---

**Background**

All the parcels fronting on Ridge Street are located within the Ridge Street ADC district. The parcels fronting on Cherry Avenue are not in a design control district. However, the recently approved Planned Unit Development included a requirement that “The entire William Taylor Plaza Planned Unit Development (PUD), all phases, shall be subject to the Board of Architectural Review (BAR) as it applies all pertinent design standards and guidelines to this project in keeping with the Ridge Street Architectural Design Control (ADC) District.”

May 18, 2004 – On the same parcels but different applicant: Preliminary Discussion with the BAR on “Cherry Ridge Commons,” William Atwood, architect.

July 20, 2004 – Preliminary discussion with the BAR on “Cherry Ridge Commons,” William Atwood, architect.

-----  
October 6, 2008 - City Council agreed to convey two parcels of City-owned land to the developer.

January 20, 2009 – Preliminary discussion with BAR and current applicant.

July 21, 2009 Preliminary – Preliminary discussion with the BAR. The Chair requested that staff summarize the BAR’s discussion.

September 9, 2009 – The Planning Commission recommended approval of the PUD with proffers. The proffers will be revised prior to City Council’s consideration. Please note that the landscaped pedestrian median that is shown on the plan in Ridge Street is not required by the proffers.

September 15, 2009 - The BAR accepted (5-0-1 with Adams recusing) applicant’s deferral. The application was not properly before the BAR since the rezoning is still pending.

November 2, 2009 – City Council approved the rezoning to Planned Unit Development (PUD) with proffers.

November 17, 2009 - The BAR approved the application (6-1-1 with Brennan against and Adams recused) in concept, with the stipulation that detailed architectural designs, building

materials, colors, and detailed site/landscaping design shall come back to the BAR for approval, also the BAR voiced strong support for a landscaped median on Ridge Street.

-----  
July 20, 2015 – City Council approved amendments to the 2009 William Taylor Plaza PUD.

August 19, 2015 – The BAR had a preliminary discussion.

Consensus was the proposal was too suburban; lacked pedestrian engagement along Ridge and Cherry; lacked inviting design at plaza/ important intersection corner and at rear retaining wall; lacked quality building materials; the design of the Ridge Street entrance was incompatible; and the building needs to relate in massing and scale to context of neighborhood and surrounding buildings in historic district.

September 14, 2015 – The BAR held a work session on a revised design. Consensus was the design was moving in a better direction; need larger spatial break at Cherry Avenue entrance; modulate fenestration; resolve corner space to engage Ridge Street; need a good landscape design; re-design the rear retaining wall; large, shared vehicle entrance on Ridge is problematic; historicist design less important than quality materials, details, and construction.

October 20, 2015- Schwarz moved to find that the proposed new construction, including massing, and general site layout generally satisfies the BAR’s criteria and is compatible with this property and other properties in the Ridge Street ADC district, and that the BAR approves only the massing and general site layout, with the following modifications: that the applicant look at the lobby entryway and the corner at Ridge and Cherry, and continue to explore color. Mohr seconded. (8-0).

November 17, 2015- Miller moved to find that the proposed new construction satisfies the BAR’s criteria and is compatible with this property and other properties in the Ridge Street ADC district, and that the BAR approves (6-0) the proposed new building [including building materials] with the following items and details to come back to the BAR for approval:

- Ridge Street corner [including glass canopies] and plaza;
- Further site plan and planting plan development;
- Exploration of a livelier color at the Cherry edge and entry [Cherry Avenue pedestrian entrance and lower garage entry]
- Exterior lighting plan and signage.

Additional work was recommended on the rear retaining wall, such as more terracing or landscaping.

December 15, 2015 - Miller moved to find that the BAR approves the proposed new building and site design details as submitted with the following modifications:

- eliminate the sidewalk colored pavers and floating seat wall from the plaza;
- change Redbuds on plaza back to Red Maples;
- raise the canopy on the plaza side, and continue to refine, submitting any changes via email;
- institute lighting controls;
- replace upright shrubs on retaining walls with leafing or draping ones; and
- replace the Japanese Beauty Berry with the American Beauty Berry.

Seconded by Schwartz. Motion passes (8-0). [ Final elevations, site plan and landscape plan drawings with the requested changes to be submitted in digital form for circulation to the BAR.]

March 15, 2016 – The BAR affirmed that all the remaining conditions of approval had been satisfied except two: The corner plaza brick façade and the related signage.

### **Application**

Background: The current owner is requesting a certificate of appropriateness for Phase One of a new mixed-use Planned Unit Development on the corner of Ridge Street and Cherry Avenue. The proposed project will be built on a total of 2.9 acres.

The BAR previously received a correct and updated copy of the PUD approval from July 20, 2015, “Approved Plan.” That packet includes the ordinance, amended proffers, and drawings such as Existing Conditions, Land Use Plan, Phasing Plan, and Matrix of permitted Use Types.

Two phases are proposed, the 2.4 acre Cherry Avenue Phase (Phase One) and the 0.4 acre Ridge Street Phase (Phase Two). Since the developer is choosing to develop the Cherry Avenue Phase first, the plan stipulates that existing trees in the Ridge Street phase shall remain undisturbed until site plan approval has been granted for the Ridge Street phase, except invasive species may be removed.

Phase One includes a proposed hotel, retail space, parking, and the arboretum area. No residential units are proposed in Phase One. Phase Two may be residential or mixed use.

The new hotel is designed with 4 levels, with 2 levels of parking under the building. On the main level there is a rear drive-up entrance with a *porte cochere* that provides access to a lobby, and a pedestrian entrance from Cherry Avenue that leads into a corridor to the same lobby. On the second level at the Ridge Street end there is a commercial space and a secondary entrance to hotel, both accessed from a small plaza on Ridge Street. There is also a meeting room that has only an interior access. The third and fourth levels are all guest rooms.

There are two levels of parking under the building. The lower level has a vehicular entrance on the west side, visible from Cherry Avenue, and a bike room with outside bike racks at the SW corner of the building. The second level has a vehicular entrance on the north (rear) side, and a pedestrian entrance from Cherry Avenue.

- In addition to the garage parking, there is a surface parking lot below the level of the future Ridge Street buildings. The proffers state that a minimum of 60% of the total project parking will be accommodated in structured parking under the buildings. Parked cars will not be visible from Ridge Street.
- The arboretum must occupy at least 25% of the site, with public access during daylight hours.
- The Phase Two area must provide an effective buffer from the surface parking lot.

The building re-design shows three layers with different materials.

- Layer 1: Brick running bond, Cushwa Redland (corbl every other course below water table) Storefronts and windows are Milk White aluminum.

- Layer 2: Fine texture stucco in Sherwin Williams Anonymous or Camelback. Storefronts and windows are Night Hawk Gray.
- Layer 3: Hardie fiber cement clapboard (smooth face with bead) in color Cobblestone. Windows are color Sea Wolf Gray.

#### Other elements

- Precast stone water tables, lintels – Arctic White (smooth)
- Perforated decorative metal panels on garage openings – Grecian pattern, color- Milk White
- Porous concrete pavers- Umbriano style, color Winter Marvel
- PTAC exterior grilles – linear louvres, color to match window frame
- Marquee canopy/porte cochere cladding - beige
- Cherry Avenue areaway railings – agate gray with stainless steel cable
- Retaining wall guardrail – matte black aluminum
- Picket fence and vehicle guardrail – dark walnut stain
- Segmental retaining wall system – AB Fieldstone Europa – Abbey blend
- Light fixtures – matte black
- Awnings – Sunbrella Sapphire (stripe)

#### Current application:

The building design has been approved by the BAR *except* for the unresolved condition: “raise the canopy on the plaza side, and continue to refine.” The BAR has not been able to come to consensus via email, so staff suggested to the applicant that they submit a wrapped balcony version per Mohr’s suggestion, then the BAR could discuss both options at the April 19 BAR meeting and decide on one or the other.

Mohr suggested extending the balconies around the corner to the first row of windows. Some members preferred to have balconies only on the Ridge Street façade.

#### **Criteria, Standards and Guidelines**

(Note: Same as current BAR staff reports.)

#### **Pertinent Design Guidelines for New Construction**

(Note: Guidelines related to the July 20, 2021 discussion only.)

##### L. FOUNDATION and CORNICE

1. Distinguish the foundation from the rest of the structure through the use of different materials, patterns, or textures.
2. Respect the height, contrast of materials, and textures of foundations on surrounding historic buildings.
3. If used, cornices should be in proportion to the rest of the building.
4. Wood or metal cornices are preferred. The use of fypon may be appropriate where the location is not immediately adjacent to pedestrians.

##### M. MATERIALS & TEXTURES

1. The selection of materials and textures for a new building should be compatible with and complementary to neighboring buildings.
2. In order to strengthen the traditional image of the residential areas of the historic districts, brick, stucco, and wood siding are the most appropriate materials for new buildings.

3. In commercial/office areas, brick is generally the most appropriate material for new structures. “Thin set” brick is not permitted. Stone is more commonly used for site walls than buildings.
4. Large-scale, multi-lot buildings, whose primary facades have been divided into different bays and planes to relate to existing neighboring buildings, can have varied materials, shades, and textures.
5. Synthetic siding and trim, including, vinyl and aluminum, are not historic cladding materials in the historic districts, and their use should be avoided.
6. Cementitious siding, such as HardiPlank boards and panels, are appropriate.
7. Concrete or metal panels may be appropriate.
8. Metal storefronts in clear or bronze are appropriate.
9. The use of Exterior Insulation and Finish Systems (EIFS) is discouraged but may be approved on items such as gables where it cannot be seen or damaged. It requires careful design of the location of control joints.
10. The use of fiberglass-reinforced plastic is discouraged. If used, it must be painted.
11. All exterior trim woodwork, decking and flooring must be painted, or may be stained solid if not visible from public right-of-way.

### **Discussion and Recommendations**

The BAR should focus their review on this site as a major gateway to the City, in addition to the neighborhood context, and whether the design meets the pertinent design guidelines and is compatible with the Ridge Street ADC historic district.

Regarding the signage, permitted signage on Ridge Street is limited to 12 sq feet, since it is in the Ridge Street ADC district. The two signs proposed on Cherry Avenue would meet the maximum 100 square foot aggregate area on that street. The applicant had originally proposed a projecting sign, but the sign ordinance allows only 3’-6’ for projecting sign, so that was not acceptable to them. Staff then suggested a monument sign of maximum 24 sq feet, which was selected. The porte cochere sign at the rear is not counted because it cannot be seen from the public road.

Therefore, the only remaining condition is the resolution of the Ridge Street façade building design.

The BAR was not in agreement on the idea of wrapping balconies around to Ridge Street. Everyone did seem to agree that the balcony brackets were oversized. The BAR needs to resolve this issue, understanding that the remainder of the building and site design have already received approval from the BAR.

### **Suggested Motion**

Having considered the standards set forth within the City Code, including City Design Guidelines for New Construction, I move to find that the proposed Ridge Street plaza façade design satisfies the BAR’s criteria and is compatible with this property and other properties in the Ridge Street ADC district, and that the BAR approves the building details of option ---as submitted (or with the following modifications...).















**1** SOUTHWEST ELEVATION  
SCALE: 3/32" = 1'-0"

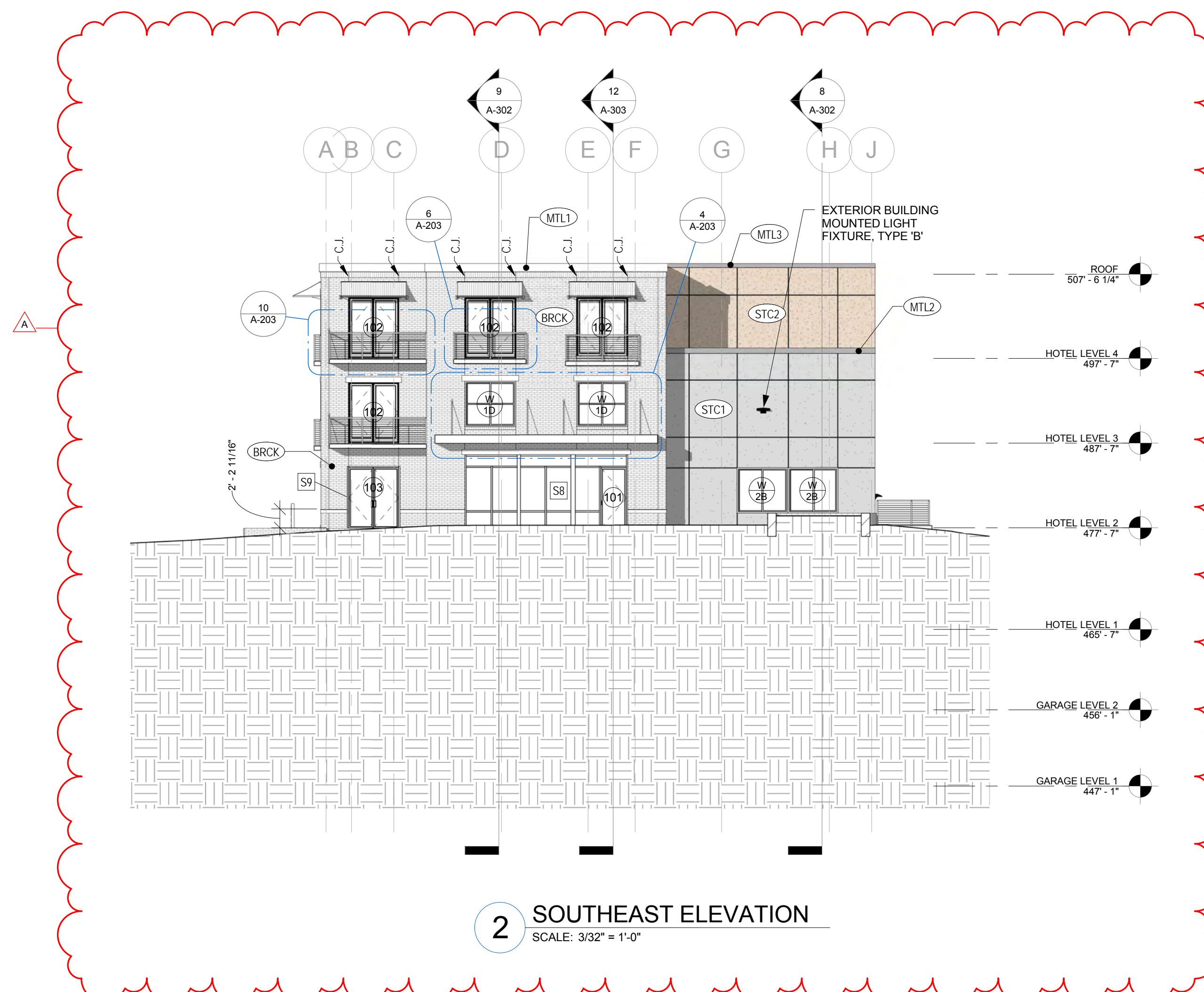

**2** SOUTHEAST ELEVATION  
SCALE: 3/32" = 1'-0"

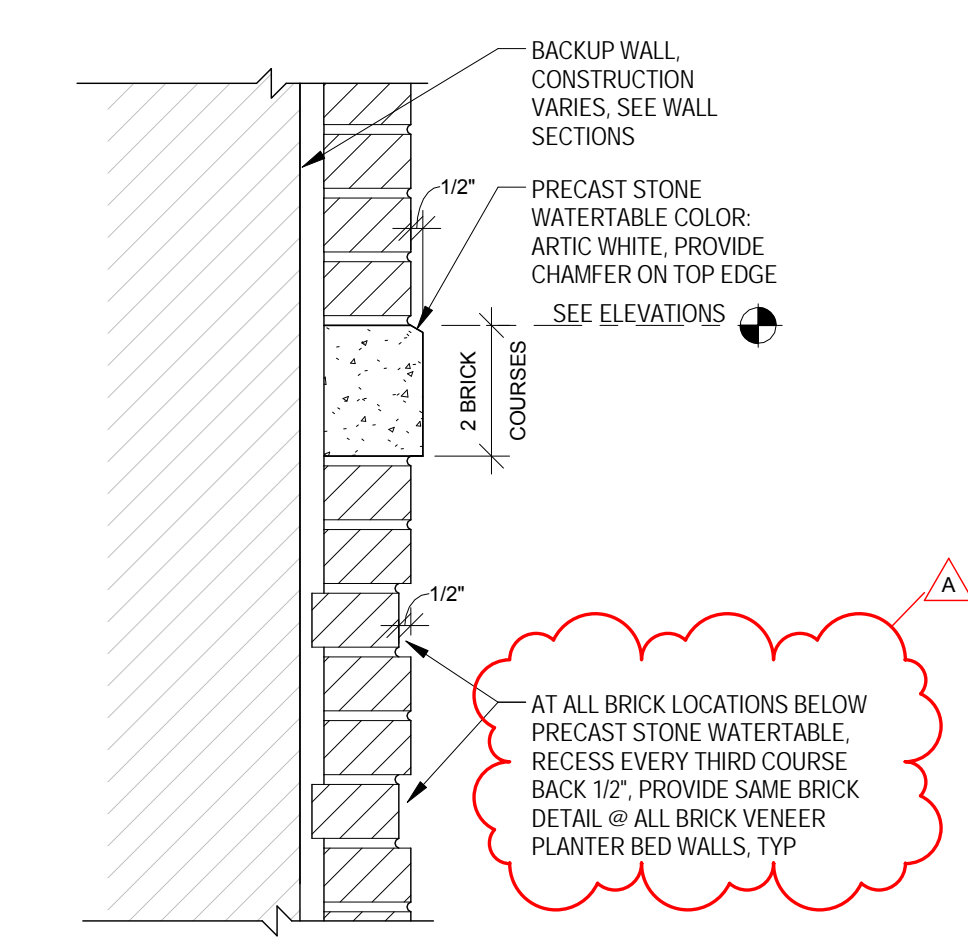

**3** PRECAST STONE WATERTABLE  
SCALE: 1 1/2" = 1'-0"

EXTERIOR FINISH KEY	
(STC1)	STUCCO - COLOR SW 7046 ANONYMOUS
(STC2)	STUCCO - COLOR SW 6122 CAMELBACK
(STC3)	STUCCO - COLOR SW 6349 PENNYWISE
(BRCK)	CUSHWA BRICK - COLOR #103 GEORGIAN
(CLBD)	CLAPBOARD - COLOR COBBLESTONE
(MTL1)	METAL - COLOR MILK WHITE (MATCH)
(MTL2)	METAL - COLOR NIGHT HAWK GRAY (MATCH)
(MTL3)	METAL - COLOR SEA WOLF (MATCH)

**BCA ARCHITECTS & ENGINEERS**  
 ARCHITECTS  
 ENGINEERS

BUILDING ELEVATIONS  
 MARRIOTT FAIRFIELD INN & SUITES  
 WILLIAM TAYLOR PLAZA PUD (PH 1)  
 CORNER OF RIDGE STREET AND CHERRY AVENUE  
 CITY OF CHARLOTTESVILLE, VIRGINIA

REVISIONS  
 A 06/20/17

THE CONTRACTOR SHALL FIELD VERIFY ALL DIMENSIONS AT THE SITE & NOTIFY THE ENGINEER IN WRITING OF ANY DISCREPANCIES.  
 Drawn By: TJW  
 Checked By: ATG  
 Scale: As indicated  
 Date: 11/14/2016  
 File No: 2015-016  
 Sheet No: **A-200**  
 FOR CONSTRUCTION

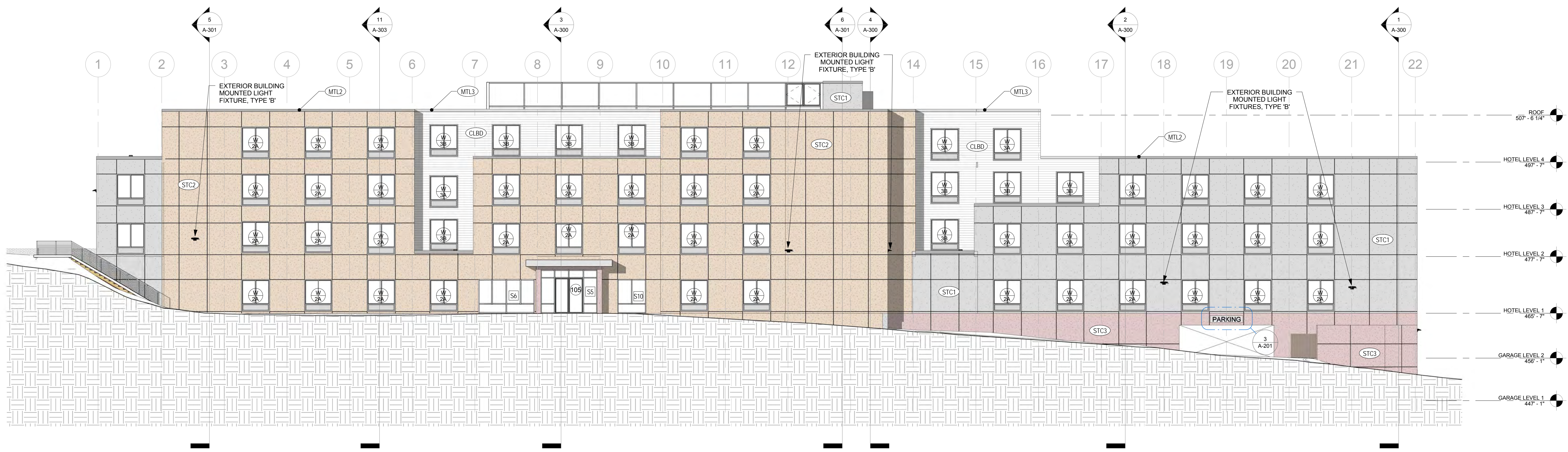

**1** NORTHEAST ELEVATION  
SCALE: 3/32" = 1'-0"

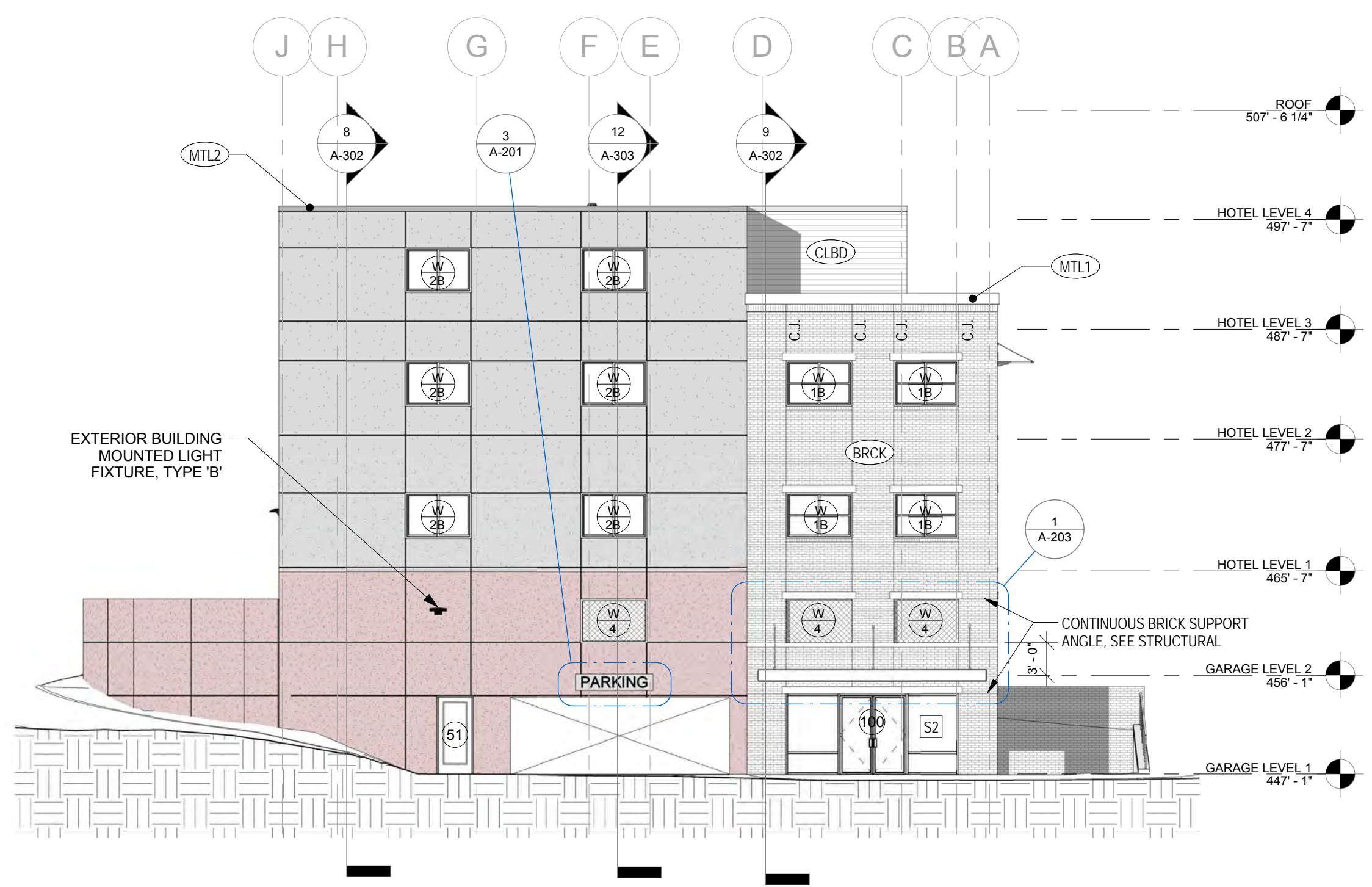

**2** NORTHWEST ELEVATION  
SCALE: 3/32" = 1'-0"

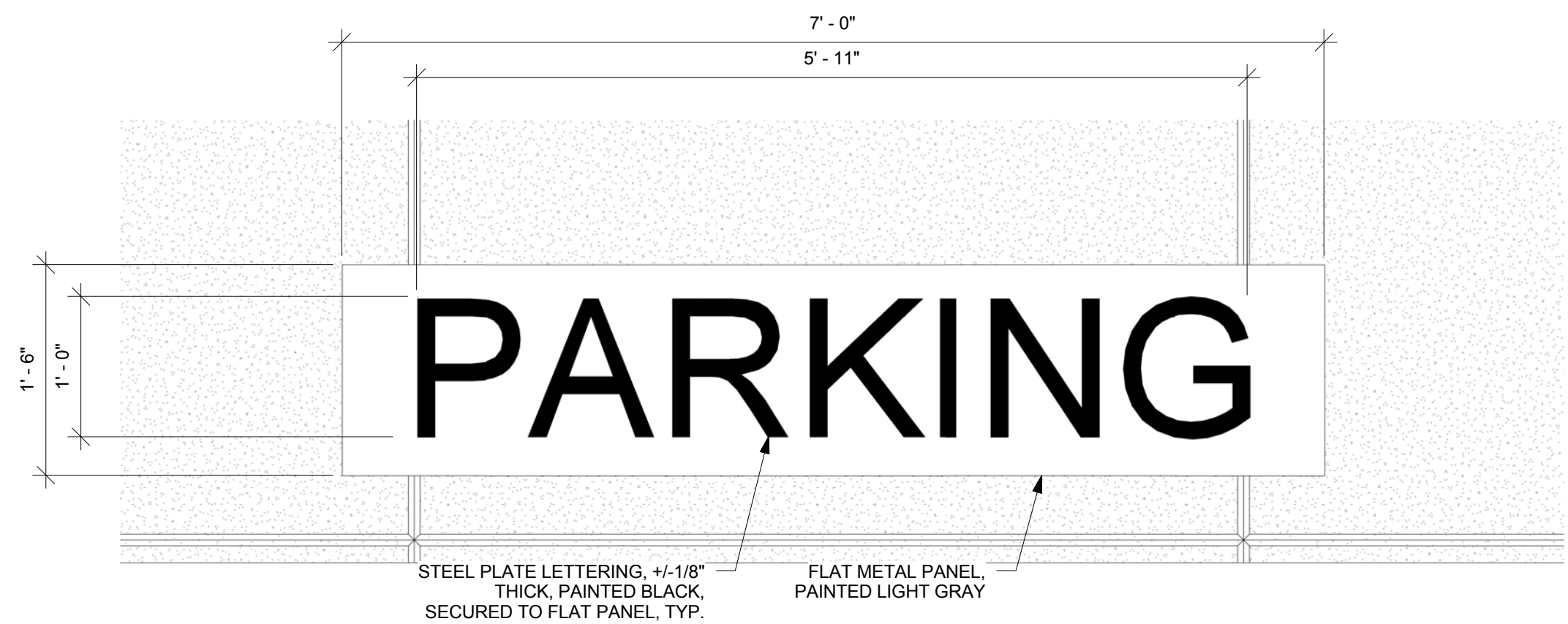

**3** PARKING GARAGE SIGNAGE  
SCALE: 1" = 1'-0"

EXTERIOR FINISH KEY	
(STC1)	STUCCO - COLOR SW 7046 ANONYMOUS
(STC2)	STUCCO - COLOR SW 6122 CAMELBACK
(STC3)	STUCCO - COLOR SW 6349 PENNYWISE
(BRCK)	CUSHWA BRICK - COLOR #103 GEORGIAN
(CLBD)	CLAPBOARD - COLOR COBBLESTONE
(MTL1)	METAL - COLOR MILK WHITE (MATCH)
(MTL2)	METAL - COLOR NIGHT HAWK GRAY (MATCH)
(MTL3)	METAL - COLOR SEA WOLF (MATCH)

**BCA ARCHITECTS & ENGINEERS**  
 COPYRIGHT 2016, BCA ARCHITECTS & ENGINEERS. ALL RIGHTS RESERVED. REUSE OF THESE DOCUMENTS WITHOUT THE EXPRESS WRITTEN PERMISSION OF BCA ARCHITECTS & ENGINEERS IS PROHIBITED.

**BCA**  
 ARCHITECTS  
 ENGINEERS

**BUILDING ELEVATIONS**  
 MARRIOTT FAIRFIELD INN & SUITES  
 WILLIAM TAYLOR PLAZA PUD (PH 1)  
 CORNER OF RIDGE STREET AND CHERRY AVENUE  
 CITY OF CHARLOTTESVILLE, VIRGINIA

REVISIONS  
 A 06/20/17

THE CONTRACTOR SHALL FIELD VERIFY ALL DIMENSIONS AT THE SITE & NOTIFY THE ENGINEER IN WRITING OF ANY DISCREPANCIES.

Drawn By ATG	Checked By ATG
Scale As indicated	Date 11/14/2016
File No 2015-016	
Sheet No. <b>A-201</b>	
FOR CONSTRUCTION	

**GENERAL NOTES:**  
PLEASE SEE SUPPLEMENTAL PACKAGE FOR INFORMATION REGARDING THE PAREX OPTIMUM WATERMASTER CI EIFS SYSTEM INSTALLATION AND DETAILS.  
ALL EXHAUST VENTS / LOUVERS TO BE REMOVED AND RE-ATTACHED ONCE NEW EIFS SYSTEM IS INSTALLED - THUS PREVENTING ANY CRACKING OR OTHER DAMAGE - TYP.

**NOTE:**  
EXISTING HARD COAT STUCCO TO REMAIN. REPAIR AS REQUIRED TO ADEQUATELY INSTALL NEW EIFS SYSTEM PER MANUFACTURERS WRITTEN INSTRUCTIONS.  
EXISTING WALL CONSTRUCTION / STOREFRONT / DOORS TO REMAIN UNDISTURBED - TYP.

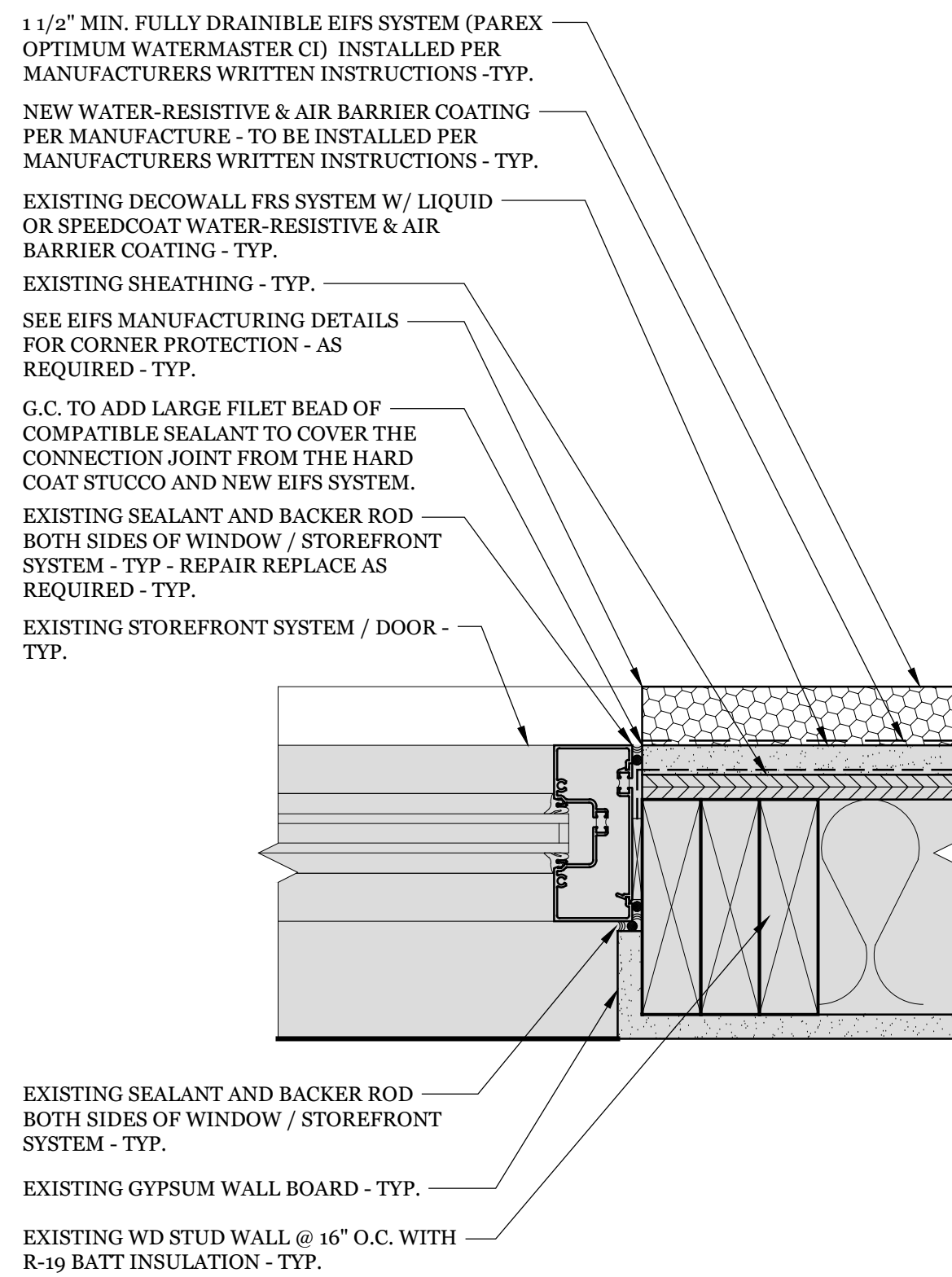

**6** Plan Detail @ Window / Storefront Jamb  
3" = 1'-0"

**NOTE:**  
EXISTING HARD COAT STUCCO TO REMAIN. REPAIR AS REQUIRED TO ADEQUATELY INSTALL NEW EIFS SYSTEM PER MANUFACTURERS WRITTEN INSTRUCTIONS.  
EXISTING WALL CONSTRUCTION / STOREFRONT / DOORS TO REMAIN UNDISTURBED - TYP.

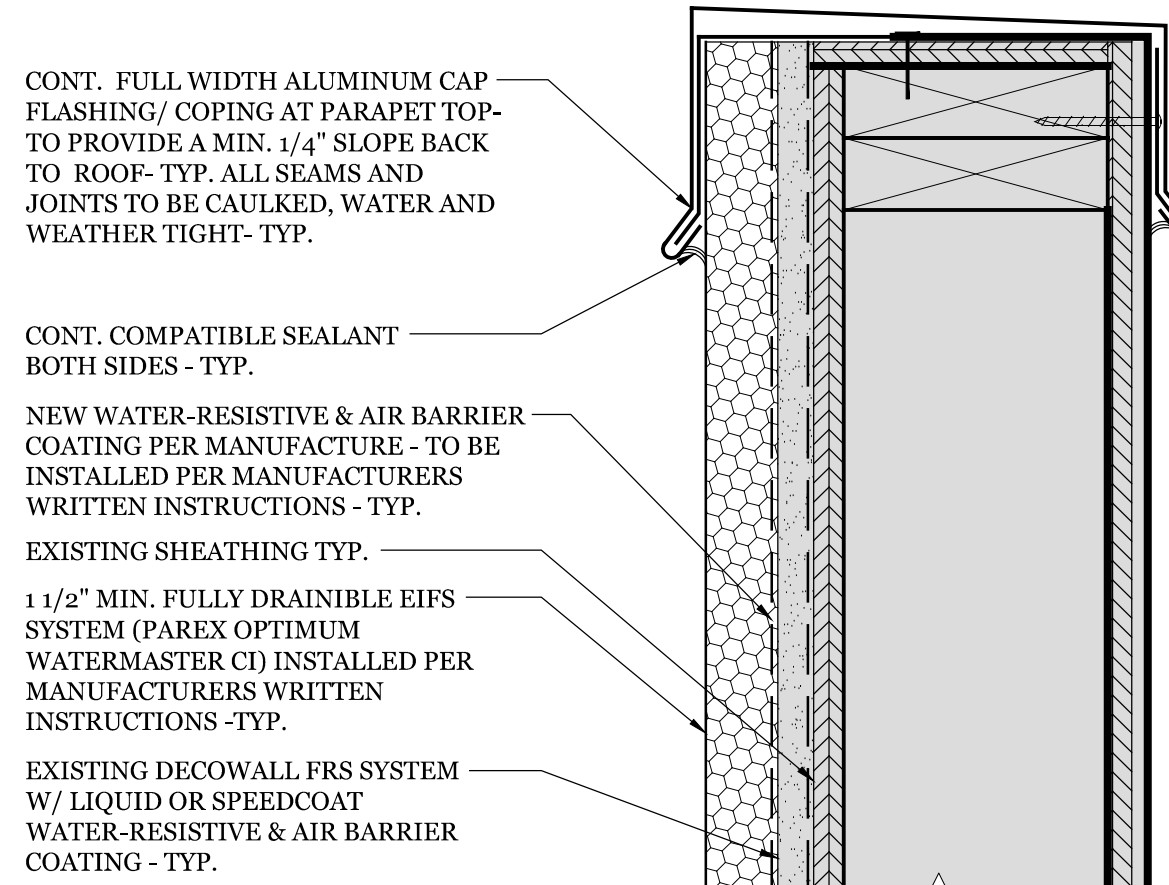

**4** Section Detail @ Parapet  
3" = 1'-0"

**NOTE:**  
EXISTING HARD COAT STUCCO TO REMAIN. REPAIR AS REQUIRED TO ADEQUATELY INSTALL NEW EIFS SYSTEM PER MANUFACTURERS WRITTEN INSTRUCTIONS.  
EXISTING WALL CONSTRUCTION / STOREFRONT / DOORS TO REMAIN UNDISTURBED - TYP.

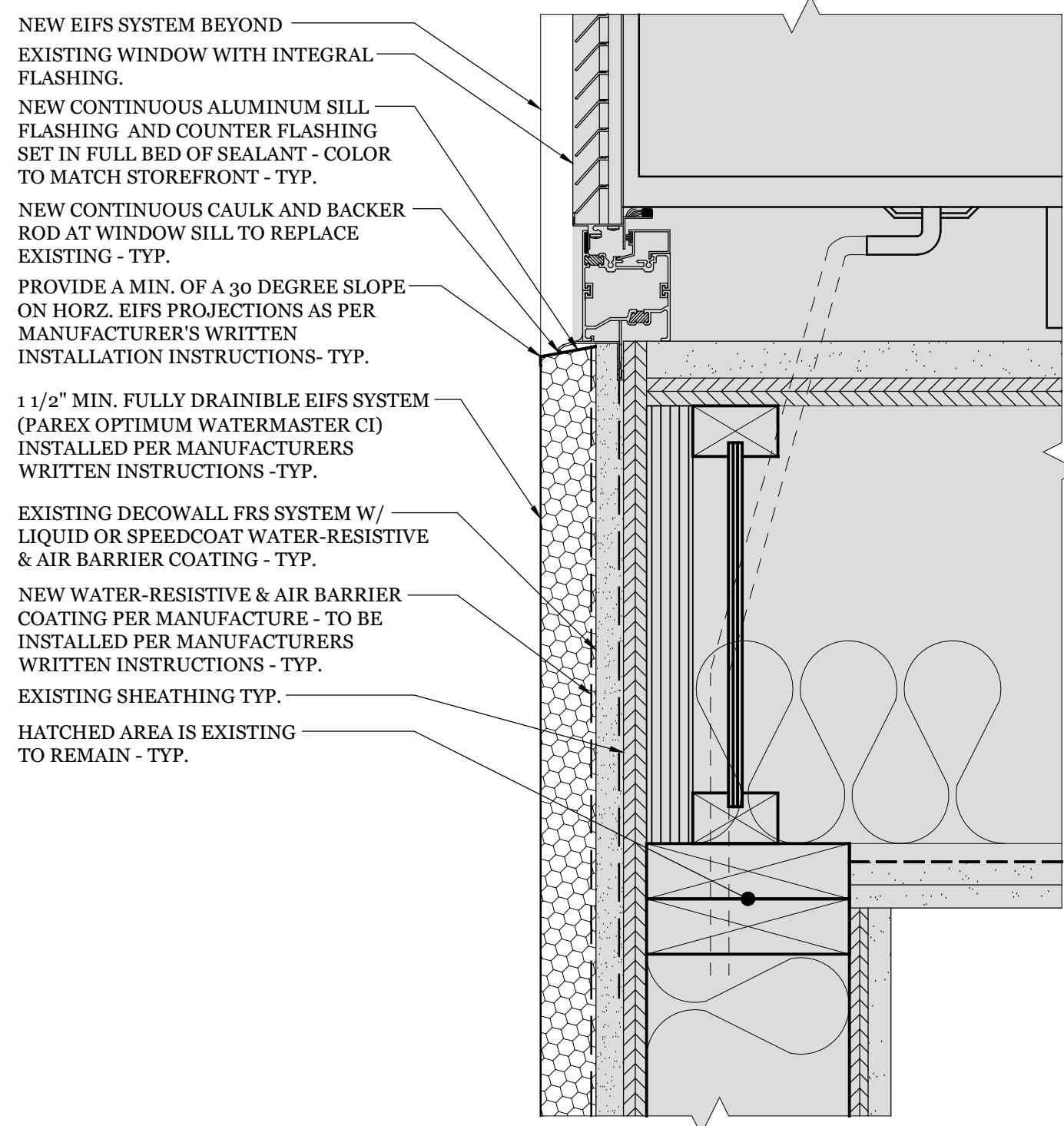

**2** Section Detail @ Window Sill  
3" = 1'-0"

**NOTE:**  
EXISTING HARD COAT STUCCO TO REMAIN. REPAIR AS REQUIRED TO ADEQUATELY INSTALL NEW EIFS SYSTEM PER MANUFACTURERS WRITTEN INSTRUCTIONS.  
EXISTING WALL CONSTRUCTION / STOREFRONT / DOORS TO REMAIN UNDISTURBED - TYP.

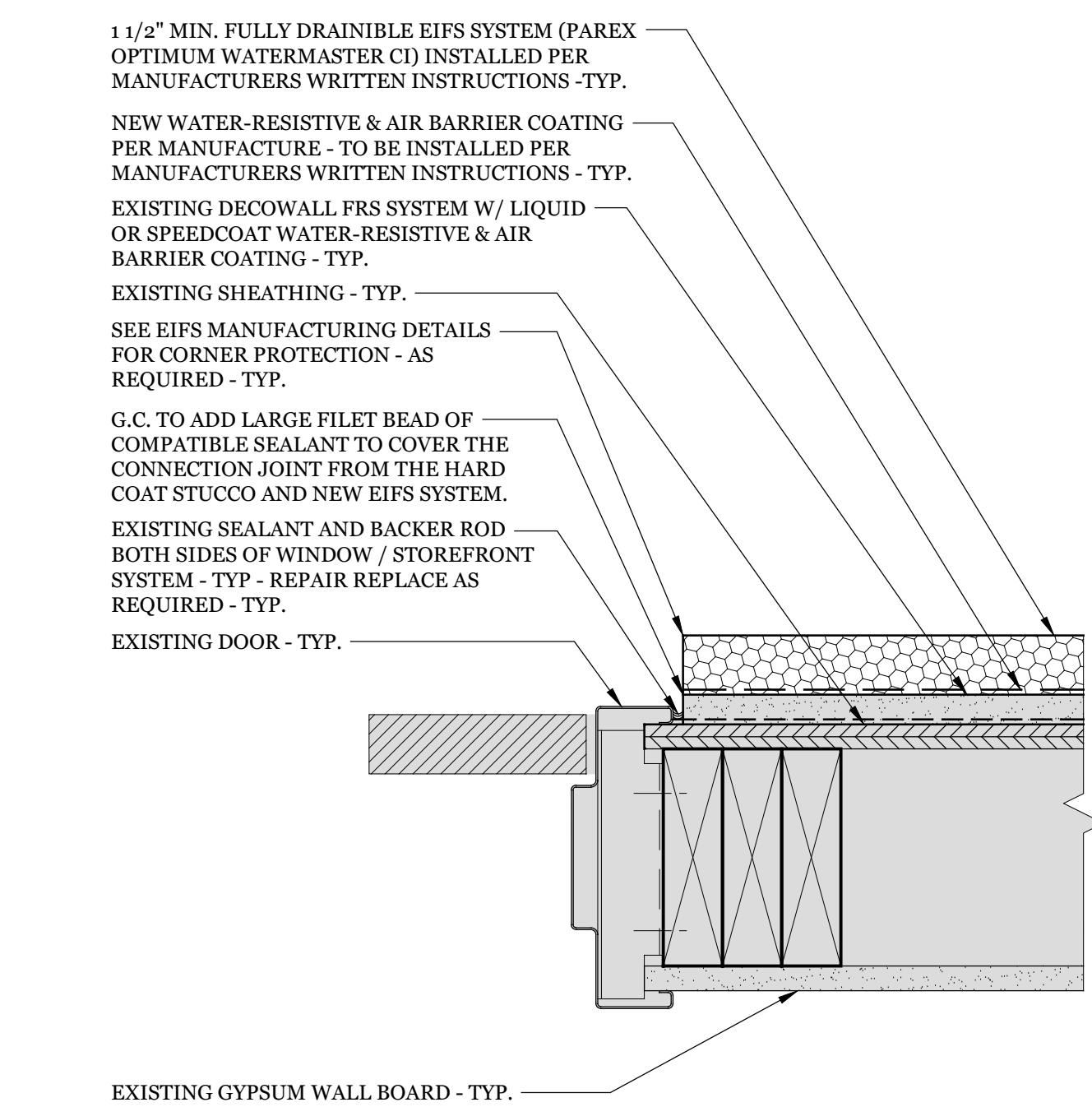

**7** Plan Detail @ Door Jamb  
3" = 1'-0"

**NOTE:**  
EXISTING HARD COAT STUCCO TO REMAIN. REPAIR AS REQUIRED TO ADEQUATELY INSTALL NEW EIFS SYSTEM PER MANUFACTURERS WRITTEN INSTRUCTIONS.  
EXISTING WALL CONSTRUCTION / STOREFRONT / DOORS TO REMAIN UNDISTURBED - TYP.

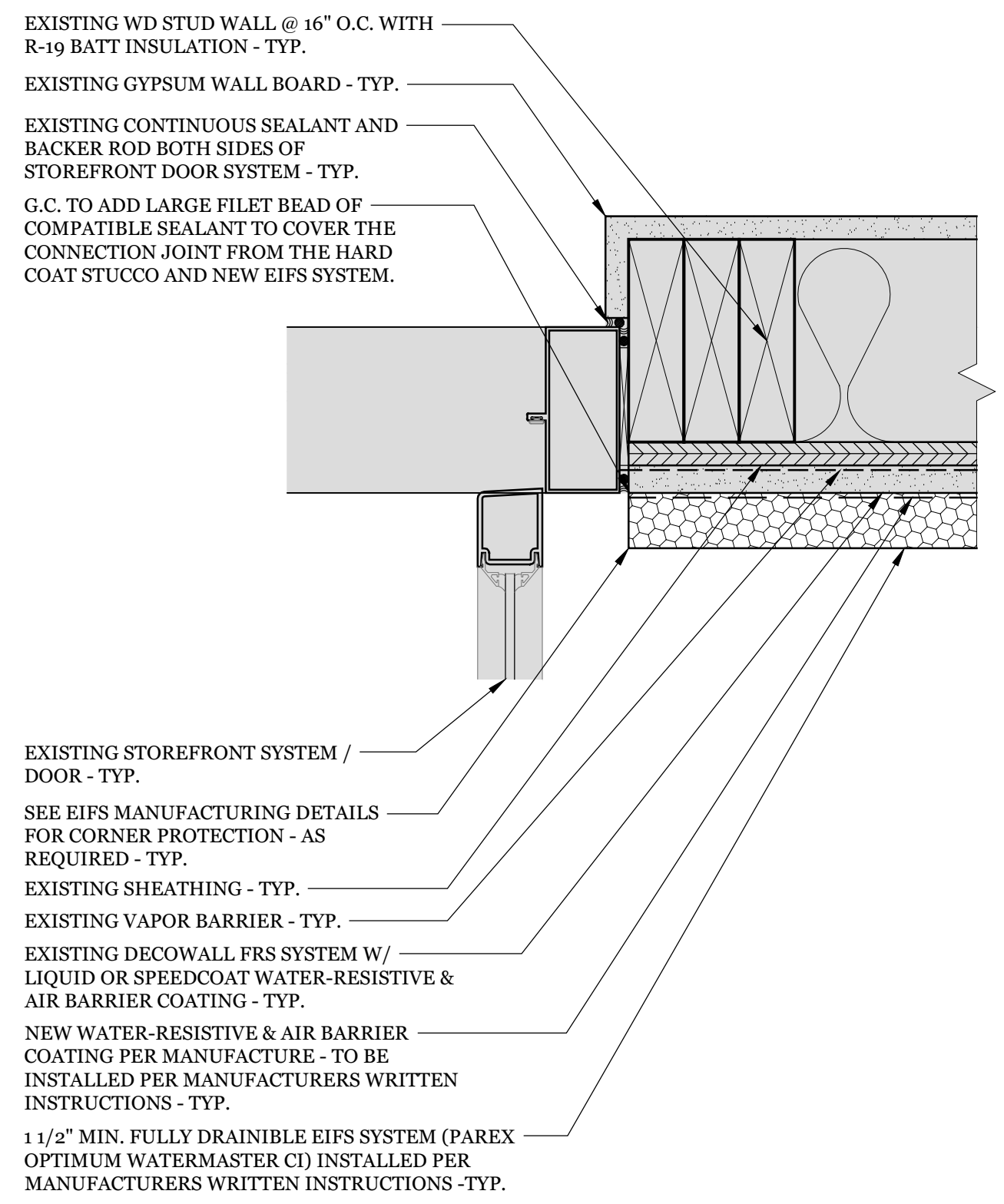

**5** Plan Detail @ Door Jamb  
3" = 1'-0"

**NOTE:**  
EXISTING HARD COAT STUCCO TO REMAIN. REPAIR AS REQUIRED TO ADEQUATELY INSTALL NEW EIFS SYSTEM PER MANUFACTURERS WRITTEN INSTRUCTIONS.  
EXISTING WALL CONSTRUCTION / STOREFRONT / DOORS TO REMAIN UNDISTURBED - TYP.

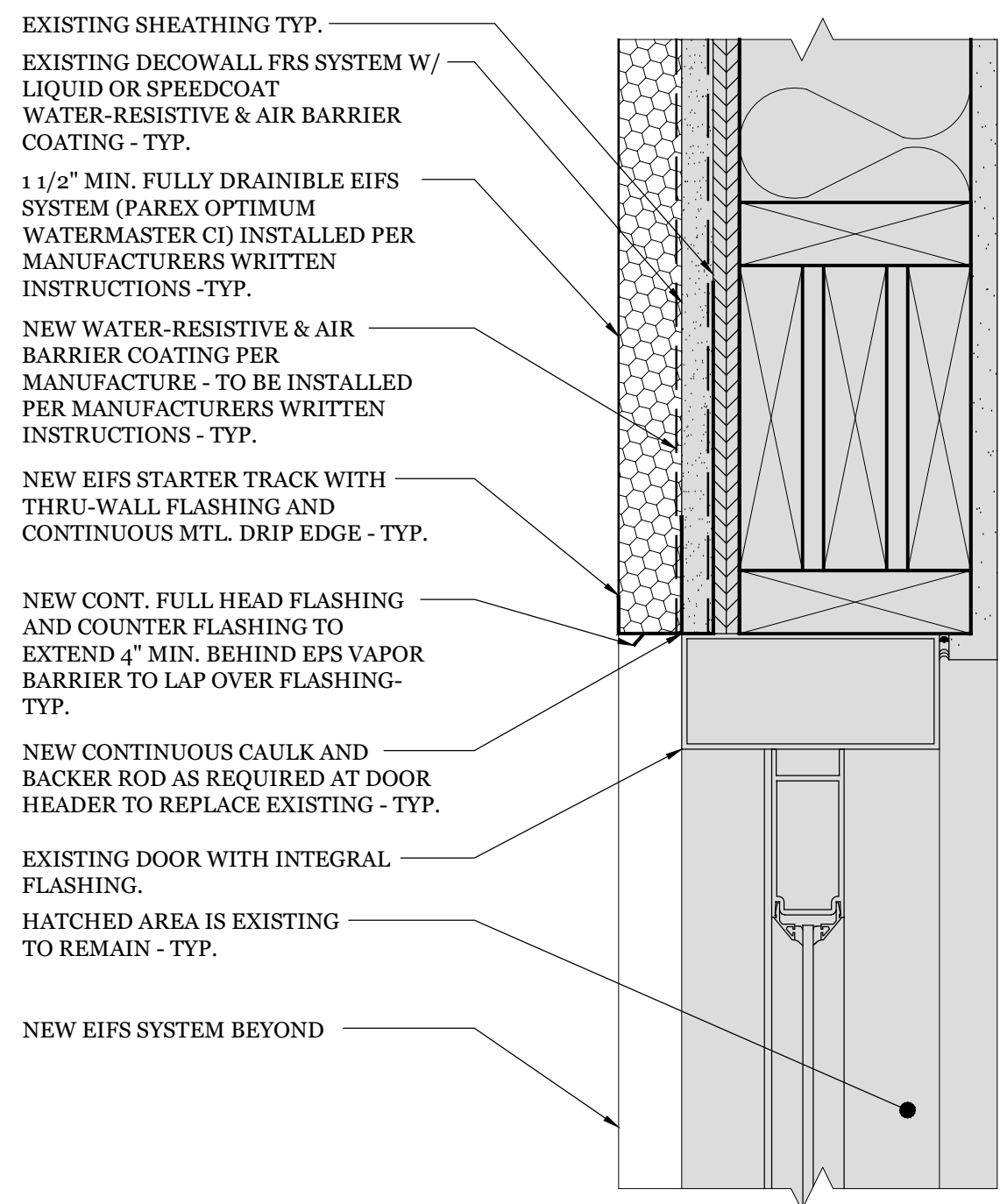

**3** Section Detail @ Door Header  
3" = 1'-0"

**NOTE:**  
EXISTING HARD COAT STUCCO TO REMAIN. REPAIR AS REQUIRED TO ADEQUATELY INSTALL NEW EIFS SYSTEM PER MANUFACTURERS WRITTEN INSTRUCTIONS.  
EXISTING WALL CONSTRUCTION / STOREFRONT / DOORS TO REMAIN UNDISTURBED - TYP.

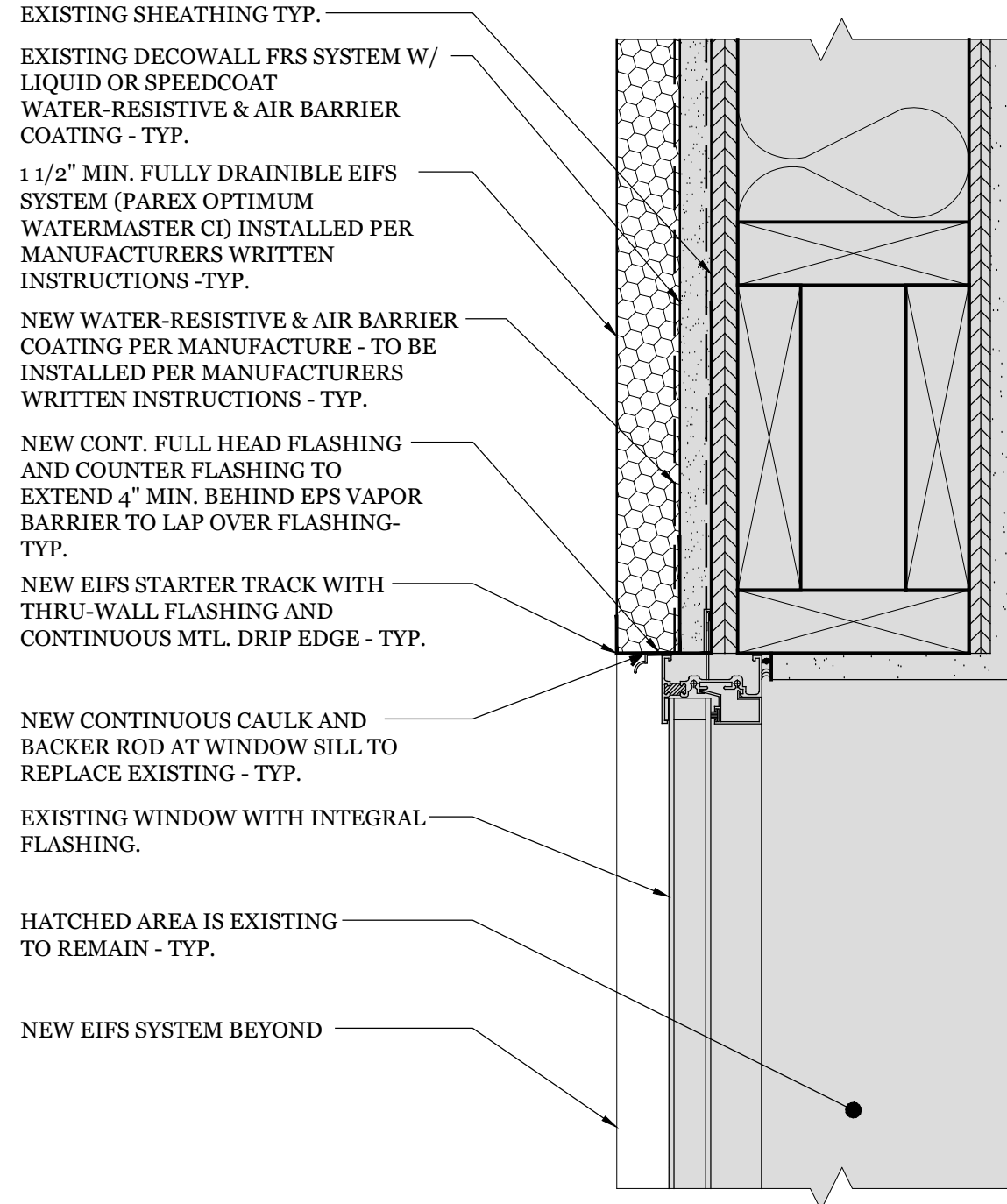

**1** Section Detail @ Window Head  
3" = 1'-0"

**Project:**  
Fairfield Inn & Suites  
401 Cherry Ave.,  
Charlottesville, VA 22903

**Owner:**  
Gateway Terrace Partners, LLC  
124 Floyd Smith Office  
Park Drive, Suite 150  
Charlotte, NC 28262



124 Floyd Smith Dr  
Suite 375  
Charlotte, NC 28262  
Tel - 704 - 688-7500

513A Savannah Hwy  
Charleston, SC 29407  
Tel - 843 - 531-6848

www.R4architecture.com

Revision	Date

Drawn By JAM  
Checked By MJR  
Issue Date 4/19/2021  
Project No  
Sheet Title  
Section Details

Sheet Number  
**A-455**

ALL DESIGNS, DRAWINGS AND SPECIFICATIONS DEPICTED ON THIS SHEET ARE THE PROPERTY OF R4ARCHITECTURE, P.A. ANY UNAUTHORIZED USE OR REPRODUCTION IS SUBJECT TO LEGAL PROSECUTION. COPYRIGHT 2021.

## PFS PREMIUM FIBERED STUCCO

888.702.9915  
www.totalwall.com

Concentrate Premium Fibered Stucco

AMERICA'S EIFS AND STUCCO COMPANY!

TOTAL WALL Premium Fibered Stucco Concentrate is a dry mix containing Portland cement, chopped strand fiberglass reinforcement, micro-fibers for added strength and crack resistance, graded aggregates, and specialty modifiers designed to enhance workability and cure.

TOTAL WALL Premium Fibered Stucco Concentrate requires sand to be added in addition to water .

TOTAL WALL Premium Fibered Stucco Concentrate:

- Can be used as standard stucco or as one-coat, hi-lift stucco.
- Is available in 50# bags in standard gray or in a white finish grade without the larger fibers.
- May be top-coated with TOTAL WALL Premium Fibered Stucco White Finish (Tintable), T-Wall Lastic Elastomeric Coating, or any TOTAL WALL Synthetic Textured Finish Coat.



## Features

- Standard, One-Coat or Hi-Lift
- High Impact Resistance
- Extremely High Impact Resistance
- Fireproof and Mildew Resistant
- Pre-Sanded, Just Add Water

## Coverage

Estimated Coverage Per 50 LB Bag Of Mix:

- 55-65 square feet at 1/4"
- 35-40 square feet at 3/8"
- 25-30 square feet at 1/2"
- 20-25 square feet at 5/8"
- 18-20 square feet at 3/4"
- 15-18 square feet at 7/8"

## Description

### Mixing Instructions

Add up to 120 pounds of clean silica sand per 50 pound bag of Total Wall Premium Fibered Stucco Concentrate. Add approximately 2-3/4 gallons of clean water per batch (50-pound bag of TOTAL WALL Premium Fibered Stucco and 10 pounds of sand). Use low-speed mixing. After initial mixing, allow the mix to stand for 2-5 minutes then remix, adding a small amount of water to adjust workability if necessary. Mix pot-life will vary depending on temperature and batch size. An average pot-life of 40 minutes can be anticipated. TOTAL WALL Premium Fibered Stucco may be re-tempered one time if mix becomes too stiff. Final consistency should be a creamy light and easily trowelable mixture.

### Options

1. TOTAL WALL Liquid acrylic Additive may be used to replace up to 20% of the mix water during job site mixing. TOTAL WALL Liquid acrylic Additive will improve the physical strength characteristics of the product and reduce the incidence of cracking.
2. TOTAL WALL Tinted-Liquid Acrylic Additive may be added to TOTAL WALL Premium Fibered Stucco White Finish to achieve a limited range of pastel colors at the job site.
3. TOTAL WALL Synthetic Finishes or T-Wall Lastic may be used for an attractive and durable finish coating. TOTAL WALL Synthetic Finishes and T-Wall Lastic are available in several textures and unlimited colors.

### Application

TOTAL WALL Premium Fibered Stucco may be applied directly to sound raw masonry without the use of netting or lath or other reinforcement. If desired or specified, a T-Wall Bonding Agent may be applied to the substrate prior to application. If application is over painted masonry, mechanically fastened lath reinforcement plus joint and trim accessories are required. For wood or gypsum-based sheathing, a moisture barrier is required as the first layer over the

sheathing followed by mechanically fastened lath reinforcement with joint and trim accessories. All lathing must be galvanized and self-furring. Trim accessories must be galvanized, solid zinc or custom PVC components. Apply TOTAL WALL Premium Fibered Stucco using a trowel in one or more passes or lifts to achieve the prescribed thickness. When useful, employ tools such as a darby or slicker to assist in leveling the coating. If TOTAL WALL Liquid Acrylic Additive or Acrylic Tint has been added to the mix, do not moist cure the coating as the acrylic assists in the proper cure process. Coating thickness may range from a minimum of 1/4" and a maximum of 1 1/2". TOTAL WALL Premium Fibered Stucco Finish Coat may be applied once the combination brown and scratch coat base is firm and dry. TOTAL WALL Synthetic Finish may be applied within 18 hours. It is advisable to allow the TOTAL WALL Premium Fibered Stucco to cure at least 48 hours before applying T-Wall Lastic Coating.

### Handling and Storage

Do not apply to frozen or saturated surfaces. Do not apply if precipitation is forecast within 8 hours of application. Do not apply if the temperature cannot be maintained

above 40F for 24 hours. Shelf life in unopened bags is 12-18 months when stored in dry conditions. Store under cover.

### Maintenance

If damage occurs to an installed system, please contact Total Wall for information on repair.

### Precautions

This product is a Portland cement based material. Do not ingest. Avoid contact with skin and eyes. In case of contact with product or mix, flush with water. For contact with eyes, get immediate medical attention in addition to flushing. Wear safety glasses and protective clothing. Keep out of reach of children and pets. eyes, get immediate medical attention in addition to flushing. Wear safety glasses and protective clothing.

### Limitations

Apply in accordance with standard lath and plastering practices. Do not apply to frozen walls or in temperatures below freezing. Use only clean potable mix water. When possible, schedule work to avoid application in direct sun. Moist curing of product is acceptable unless TOTAL WALL Liquid acrylic Additive has been added.



## Technical Data

Meets ASTM C595 specifications for Blended Hydraulic Cement

**Chemistry** - Portland cement meets standard ASTM C150

**Aggregates** - meet standards ASTM C33, ASTM C144 and ASTM C778

**Hydration Control** - balanced lime blend meets standard ASTM C207

**Modifiers** - specialty hydrating agents and wetting agents

**Reinforcement** - natural mineral fibers plus chopped strand fiberglass

**Appearance:** Dry, gray powder

**pH (wet):** Approx. 10.5

**Density (wet):** 1.6-1.8 grams/cc

**Chemistry:** Portland cement

888.702.9915 Phone

888.702.9916 Fax

[www.totalwall.com](http://www.totalwall.com)



Warranty No: 2018-496

- 3 - YEAR LIMITED WARRANTY

Disclaimers and Limitations of Remedies

" Materials "

**decoplast**

Greenmaker Industries warrants to the below Owner that for the -3- year Warranty Period stated above and subject to the exceptions listed below, the Decowall FRS (the "system") described above, as properly applied by the Registered Applicator, will maintain its bond, be water resistant and will not peel, flake or chip. For any valid claim presented under this Warranty, Greenmaker Industries will supply Owner with replacement materials and labor required to

Repair any non-conforming portions of the installed System. Any replacement materials provided hereunder will also be subjected to all the provisions of the Warranty during the Warranty Period shown above.

WARRANTIES DISCLAIMED – THE WARRANTY STATED IN THE PARAGRAPH ABOVE IS IN PLACE OF ALL OTHER WARRANTIES, EXPRESSED OR IMPLIED. GREENMAKER INDUSTRIES EXPRESSLY DISCLAIMS ANY OTHER WARRANTIES INCLUDING WARRANTIES OF MERCHANTABILITY AND FITNESS FOR A PARTICULAR PURPOSE. ALTHOUGH GREENMAKER INDUSTRIES MAY HAVE SUGGESTED THE MATERIAL OR DEVELOPED THE MATERIAL AT THE REQUEST OF THE GC, OWNER OR OWNERS REP, IT IS THE RESPONSIBILITY OF THE MANUFACTURER TO TEST AND DETERMINE THE SUITABILITY OF THE MATERIAL FOR THE INTENDED USE AND PURPOSE, AND THE APPLICATOR ASSUMES ALL RISK AND LIABILITY WHATSOEVER REGARDING SUCH SUITABILITY IF NOT INSTALLED AS PER MANUFACTURER SPECIFICATIONS.

LIMITATIONS OF REMEDIES AND DAMAGES – THE REPLACEMENT/REFUND REMEDY STATED IN THIS WARRANTY TAKES THE PLACE OF ALL OTHER REMEDIES AGAINST GREENMAKER INDUSTRIES AND IS THE ONLY REMEDY AGAINST DECOPLAST SYSTEMS, INC. AVAILABLE TO OWNER OR TO ANY OTHER PARTY, IN NO EVENT WILL GREENMAKER INDUSTRIES BE LIABLE FOR SPECIAL, INDIRECT, INCIDENTAL OR CONSEQUENTIAL DAMAGES (INCLUDING LOST PROFITS) ARISING OUT OF OR CONNECTED TO THE MATERIALS OR THE SYSTEM, OR TO ANY USE OR MISUSE OF THE MATERIALS OR THE SYSTEM, REGARDLESS OF ANY STRICT LIABILITY OR ACTIVE OR PASSIVE NEGLIGENCE OF GREENMAKER INDUSTRIES AND REGARDLESS OF THE LEGAL THEORY (CONTRACT, TORT OR OTHER) USED TO MAKE A CLAIM, IN NO EVENT WILL GREENMAKER INDUSTRIES BE OBLIGATED TO PAY DAMAGES IN ANY AMOUNT EXCEEDING THE ORIGINAL PRICE OF THE MATERIALS SHOWN TO BE DEFECTIVE. For customer relations purposes, Greenmaker industries may in its sole discretion choose to make some

efforts beyond its legal obligations. Such additional efforts will not in any way change the limitations of remedies and damages stated in this paragraph or extend or change this Warranty.

Exclusions: The warranty described above does not cover, and Greenmaker Industries will have no liability for any damage or failure of the System caused by or due to any of the following:







1. Lightning, earthquake, windstorm, hurricane, tornado, hail, fire, flood or other unusual phenomena of the elements or acts of nature.
2. Settlement, movement, deflection, warpage, distortion, displacement or any other failure of the substrate. Such failures are the sole responsibility of the substrate manufacturer.
3. Cracks, breaks or openings in the substrate to which the System is applied.
4. Surface alterations, additions, object placed or installations made on the finished surface.
5. Use of the finished surface as something other than an exterior wall (such as a recreational area or walking surface).
6. Penetration, vandalism, damage or attack by third parties and foreign objects or agents, including but not limited to chemicals, animals and plant life.
7. Discoloration or change in visual appearance due to accumulation or streaking of dirt or other airborne materials deposited on the surface from the atmosphere.
8. Sealant failure or water penetration due to leaks through windows, air conditioning units, holes, louvers, vents, or other non-System elements made part of a System installation.
9. Other (explain):

Furthermore, the warranty described above does not cover, and Greenmaker Industries will have no liability for, any repairs to the System or repaired portions of the System, except as set forth in the sections covering Repairs and Emergency Repairs, below.

**Warranty Claims.** Owner shall notify Greenmaker Industries immediately of any alleged defect in the materials covered by this Warranty. Owner will provide Greenmaker Industries with a reasonable opportunity to review and investigate the alleged defect. For any valid claim presented under the Warranty, Greenmaker Industries will provide the Owner with a remedy as described above. For any claim that is not valid, Owner will pay Greenmaker Industries reasonable charges, including travel and labor, associated with investigation of such claim.

**Repairs.** Any portions of the System either repaired by Greenmaker Industries or repaired by Applicator and approved in writing by Greenmaker industries will be subject to the terms of this Warranty for the remainder of the Warranty Period.

**Emergency Repairs.** If immediate and material damage to the building and its contents is imminent due to an alleged failure of the System, the Owner may, at its own expense, make such temporary repairs as may reasonable be required to prevent such damage. If Greenmaker Industries thereafter determines that the temporary repairs were necessitated by a failure of the System, Greenmaker Industries will provide a remedy as described above. If Greenmaker Industries determines that such emergency repairs were made in accordance with Greenmaker Industries standards, such repaired

portions will be subject to the terms of this Warranty for the remainder of the Warranty Period. If Greenmaker Industries determines that the temporary repairs were either not necessitated by a failure

of the System, or were not made in accordance with Greenmaker Industries standards, the warranty described in this Warranty will be null and void with respect to the repaired portions of the System. In no case will



Greenmaker Industries be held responsible for any damages done to the System by others in performing any repairs.

Voidability. The limited warranty contained herein will become null and void upon notice by Greenmaker Industries if:

1. Owner fails to provide prompt notification of any alleged defect in the System.
2. Owner denies Greenmaker Industries a reasonable opportunity to review and investigate an alleged failure of the System; or
3. Owner fails to pay when due the full contract price for the System and any other charges owing to Greenmaker Industries under the terms of this Warranty; provided, however, that all other terms of this limited warranty, including warranty disclaimers and limitations of remedies and damages, will remain in full force and effect despite such a nullification.

Assignability. The transfer of this Warranty to a new owner may be made only if acknowledged in writing by Greenmaker Industries to the new owner. Greenmaker Industries must be notified at the time of sale to the new owner, and Greenmaker Industries must be satisfied that the intended use of the structure by the new owner will not cause detriment to the System.

Validation. This Warranty is void unless signed by authorized representatives of Greenmaker Industries

Complete Agreement. This Warranty completely replaces and supersedes any prior oral or written warranties agreements or representations relative to the System, The System material or the application of such materials. No one other than an officer or general manager of Greenmaker Industries is authorized to change this Warranty or any of its provisions.

**Owner:** Keystone Hotel Group  
840 W. Market Street  
Kingston, PA 18704

**Location:** Fairfield Inn  
401 Cherry Avenue  
Charlottesville, VA 22902

**Certified Applicator:** Standard Building Systems → 804-545-0781  
PO Box 70992  
Richmond, VA 23255

**General Contractor:** Purcell Construction Corp.  
7730 Whitepine Road  
Richmond, VA 23237

Company Issuing Warranty: **Greenmaker Industries**

Project Size: 18,000 sq.ft.

System Installed: Decowall FRS

Date Product Purchased: 10/15/2017

thru: 05/30/2018

Warranty Expiration Date: 05/30/2021

**Signature & Title:** *Michael Jalbert* Technical Director **Date:** 04/03/2018



697 Oakwood Avenue, West Hartford, CT 06110  
voice: 860.761.2830 fax: 860.761.2831  
www.decoplast.com

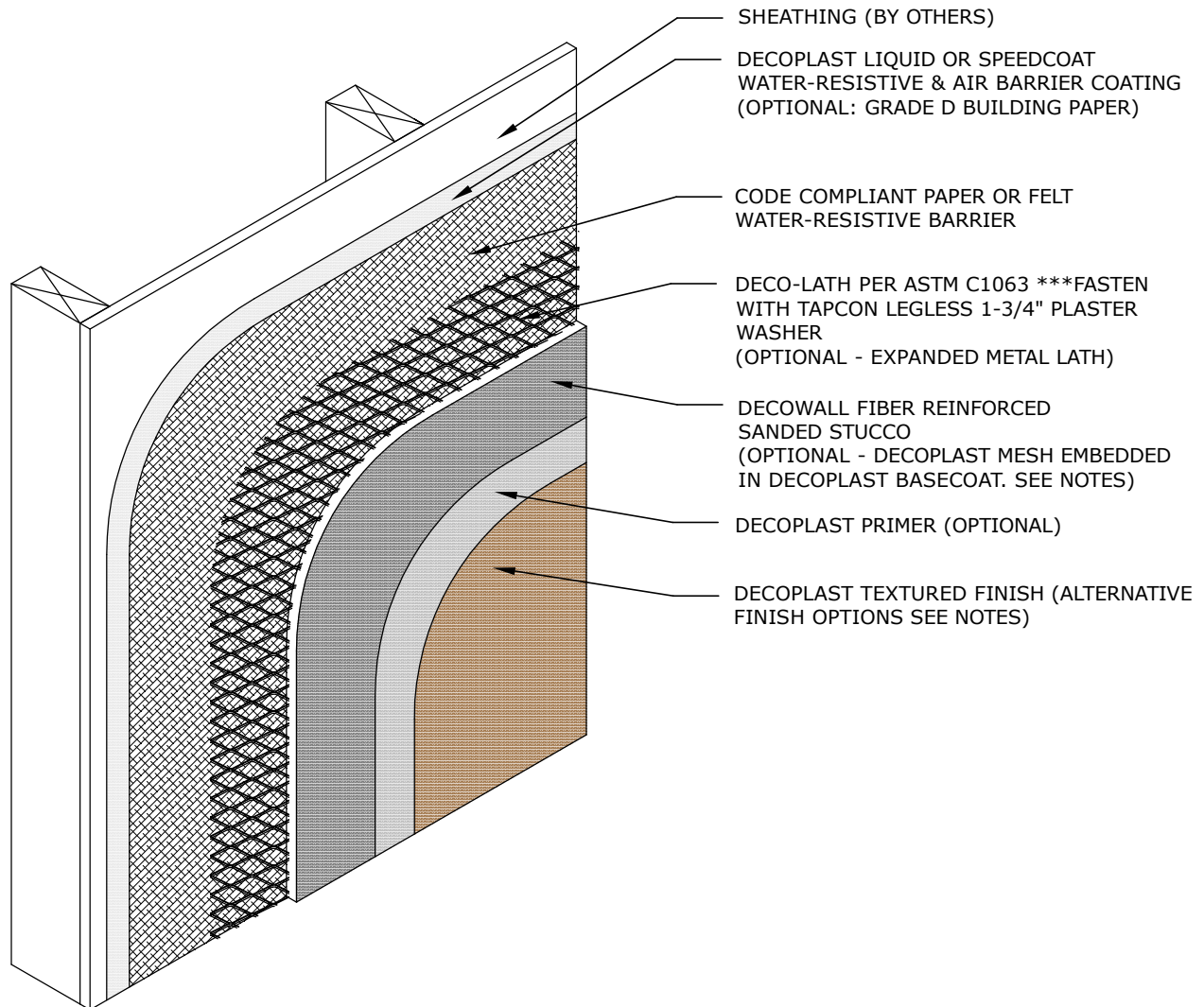

## DG1.01 DECOWALL FRS STUCCO ASSEMBLY / WOOD FRAME

DECOPLAST DECOWALL FRS - 6/1/2016

**NOTE:**

1. Stucco Claddings and any cladding using a mortar bed requires the use of a slipsheet installed over the Water-Resistive & Air Barrier Coating to prevent adhesion of the stucco.
2. Refer to Decoplast specifications specified basecoat product & thickness
3. Optional Decoplast Mesh embedded in Decoplast Basecoat may be applied over DECOWALL Fiber Reinforced Sanded Stucco to help bridge spidering.
4. Optional textured finishes: Decolastic, Deco250 and DecoSil.

Disclaimer: The design, specifications, and construction shall comply with all local building codes and standards. Decoplast installation guidelines are for general information and guidance only and Decoplast specifically disclaims any liability for the use of this design, and for design, engineering, or workmanship of any project. The assembly shall be designed to prevent condensation within the assembly. The designer and the user shall provide final drawings and specifications. Products shown other than those manufactured by Decoplast are shown for clarity of the Decoplast product only. Contact the manufacturer of such other products for installation instructions.

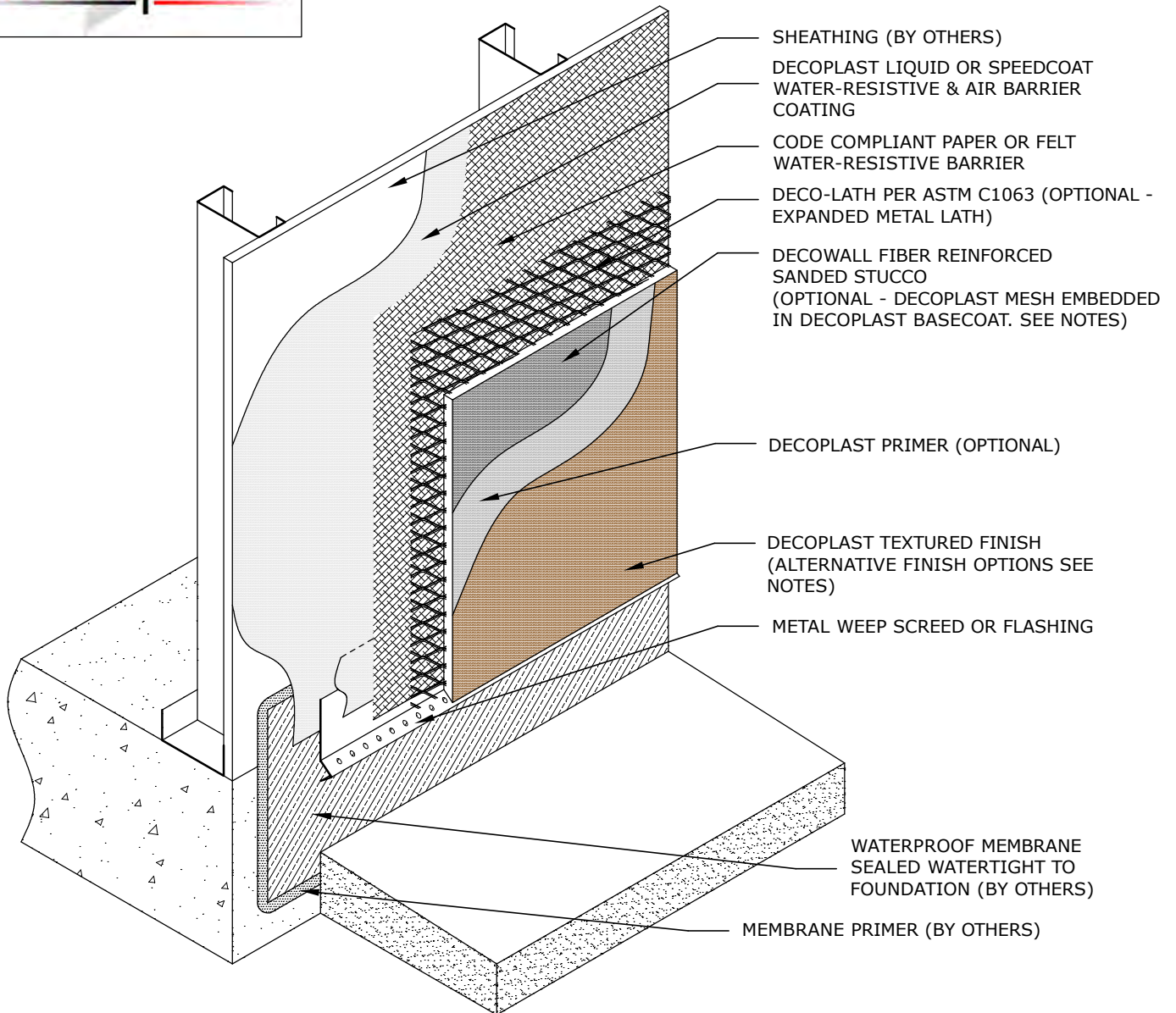

## DT1.01 DECOWALL FRS TERMINATION AT GRADE

DECOPLAST DECOWALL FRS - 6/1/2016

**NOTE:**

1. To ensure a continuous air barrier across the building envelope, a continuous air seal should be made at each substrate change, joints/gaps, penetrations and dissimilar material terminations. There must be consideration of the Designer in the overall wall assembly design.
2. Stucco Claddings and any cladding using a mortar bed requires the use of a slipsheet installed over the Water-Resistive & Air Barrier Coating to prevent adhesion of the stucco.
3. Refer to Decoplast specifications specified basecoat product & thickness
4. Optional Decoplast Mesh embedded in Decoplast Basecoat may be applied over DECOWALL Fiber Reinforced Sanded Stucco to help bridge spidering.
5. Optional textured finishes: Decolastic, Deco250 and DecoSil.

**Disclaimer:** The design, specifications, and construction shall comply with all local building codes and standards. Decoplast installation guidelines are for general information and guidance only and Decoplast specifically disclaims any liability for the use of this design, and for design, engineering, or workmanship of any project. The assembly shall be designed to prevent condensation within the assembly. The designer and the user shall provide final drawings and specifications. Products shown other than those manufactured by Decoplast are shown for clarity of the Decoplast product only. Contact the manufacturer of such other products for installation instructions.

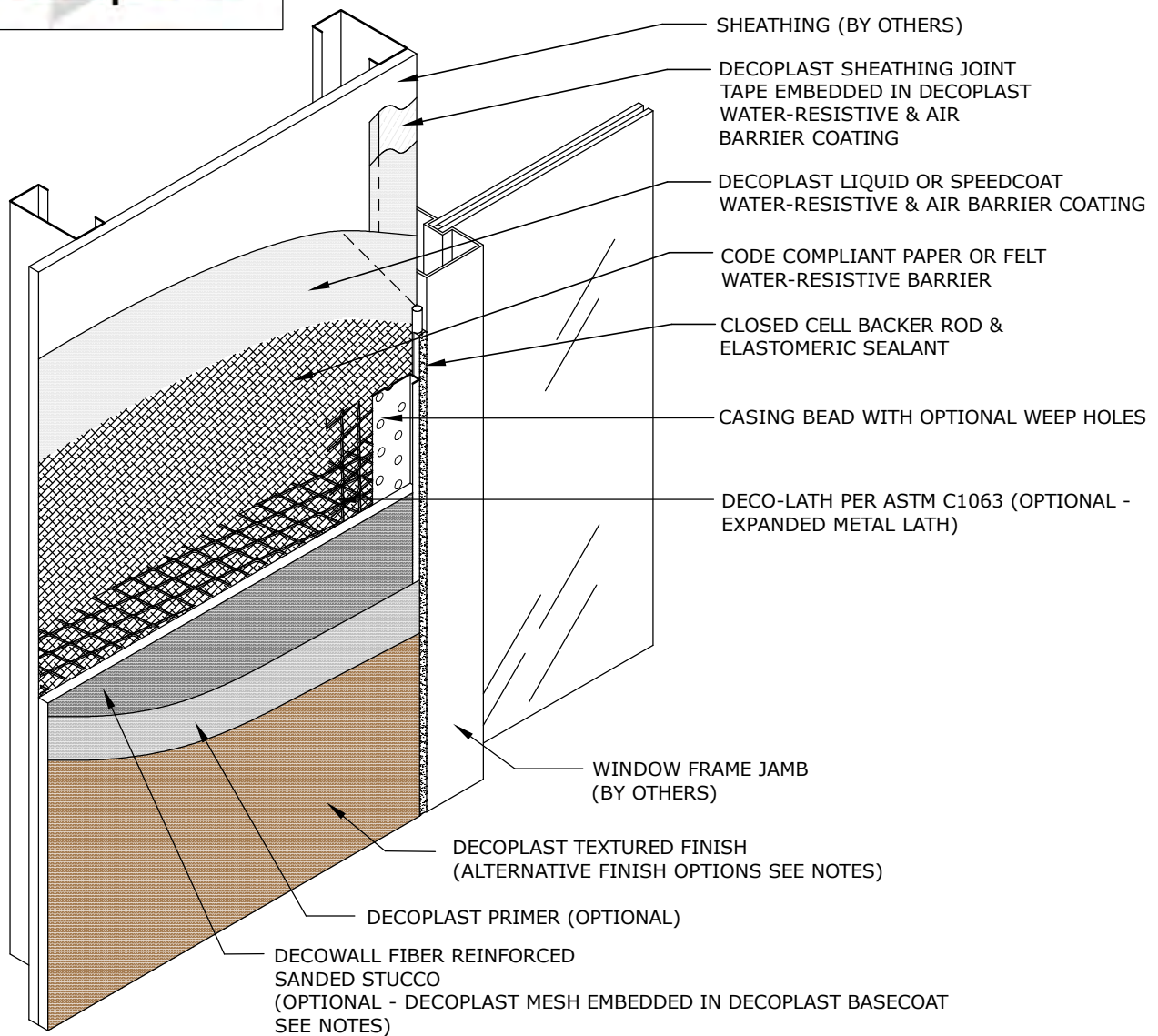

## DW1.01 DECOWALL FRS TERMINATION AT WINDOW JAMB

DECOPLAST DECOWALL FRS - 6/1/2016

### NOTE:

1. To ensure a continuous air barrier across the building envelope, a continuous air seal should be made at each substrate change, joints/gaps, penetrations and dissimilar material terminations. There must be consideration of the Designer in the overall wall assembly design.
2. Stucco Claddings and any cladding using a mortar bed requires the use of a slipsheet installed over the Water-Resistive & Air Barrier Coating to prevent adhesion of the stucco.
3. Refer to Decoplast specifications specified basecoat product & thickness
4. Optional Decoplast Mesh embedded in Decoplast Basecoat may be applied over DECOWALL Fiber Reinforced Sanded Stucco to help bridge spidering.
5. Optional textured finishes: Decolastic, Deco250 and DecoSil.

Disclaimer: The design, specifications, and construction shall comply with all local building codes and standards. Decoplast installation guidelines are for general information and guidance only and Decoplast specifically disclaims any liability for the use of this design, and for design, engineering, or workmanship of any project. The assembly shall be designed to prevent condensation within the assembly. The designer and the user shall provide final drawings and specifications. Products shown other than those manufactured by Decoplast are shown for clarity of the Decoplast product only. Contact the manufacturer of such other products for installation instructions.

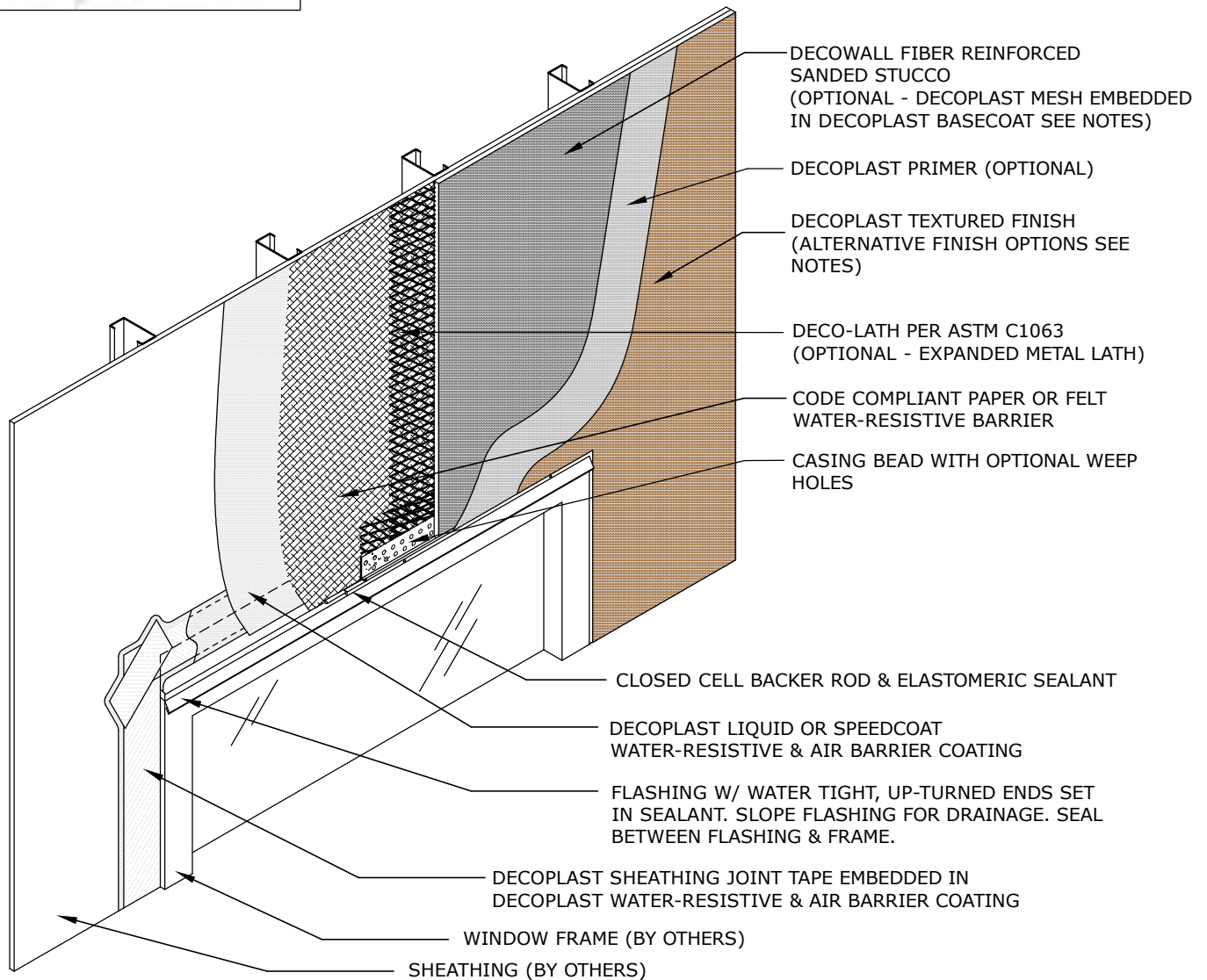

## DW1.02 DECOWALL FRS TERMINATION AT WINDOW HEAD

DECOPLAST DECOWALL FRS - 6/1/2016

### NOTE:

1. To ensure a continuous air barrier across the building envelope, a continuous air seal should be made at each substrate change, joints/gaps, penetrations and dissimilar material terminations. There must be consideration of the Designer in the overall wall assembly design.
2. Stucco Claddings and any cladding using a mortar bed requires the use of a slipsheet installed over the Water-Resistive & Air Barrier Coating to prevent adhesion of the stucco.
3. Refer to Decoplast specifications specified basecoat product & thickness
4. Optional Decoplast Mesh embedded in Decoplast Basecoat may be applied over DECOWALL Fiber Reinforced Sanded Stucco to help bridge spidering.
5. Optional textured finishes: Decolastic, Deco250 and DecoSil.

Disclaimer: The design, specifications, and construction shall comply with all local building codes and standards. Decoplast installation guidelines are for general information and guidance only and Decoplast specifically disclaims any liability for the use of this design, and for design, engineering, or workmanship of any project. The assembly shall be designed to prevent condensation within the assembly. The designer and the user shall provide final drawings and specifications. Products shown other than those manufactured by Decoplast are shown for clarity of the Decoplast product only. Contact the manufacturer of such other products for installation instructions.

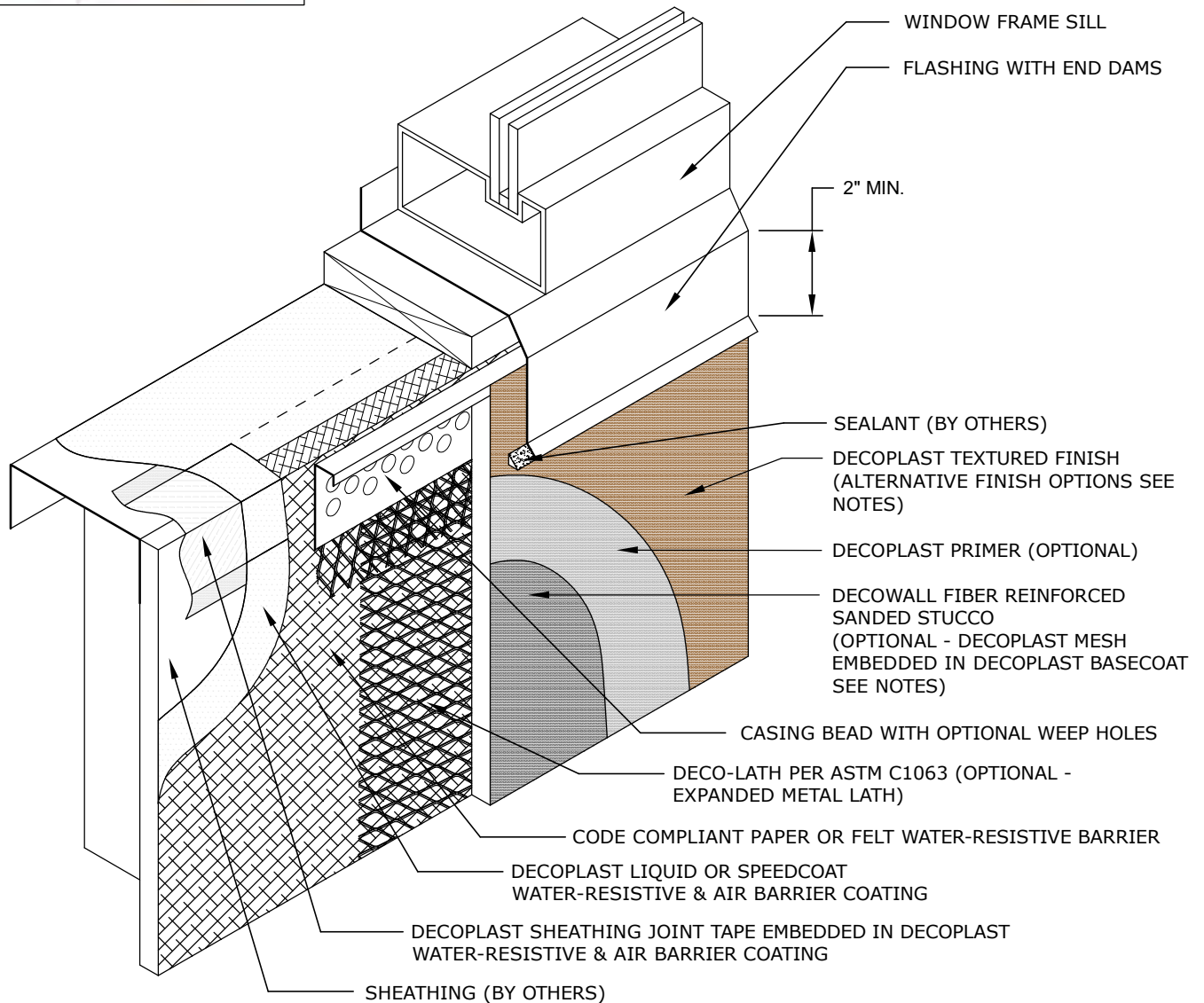

## DW1.03 DECOWALL FRS TERMINATION AT WINDOW SILL

DECOPLAST DECOWALL FRS - 6/1/2016

**NOTE:**

1. To ensure a continuous air barrier across the building envelope, a continuous air seal should be made at each substrate change, joints/gaps, penetrations and dissimilar material terminations. There must be consideration of the Designer in the overall wall assembly design.
2. Stucco Claddings and any cladding using a mortar bed requires the use of a slipsheet installed over the Water-Resistive & Air Barrier Coating to prevent adhesion of the stucco.
3. Refer to Decoplast specifications specified basecoat product & thickness
4. Optional Decoplast Mesh embedded in Decoplast Basecoat may be applied over DECOWALL Fiber Reinforced Sanded Stucco to help bridge spidering.
5. Optional textured finishes: Decolastic, Deco250 and DecoSil.

Disclaimer: The design, specifications, and construction shall comply with all local building codes and standards. Decoplast installation guidelines are for general information and guidance only and Decoplast specifically disclaims any liability for the use of this design, and for design, engineering, or workmanship of any project. The assembly shall be designed to prevent condensation within the assembly. The designer and the user shall provide final drawings and specifications. Products shown other than those manufactured by Decoplast are shown for clarity of the Decoplast product only. Contact the manufacturer of such other products for installation instructions.

## WATERMASTER CI

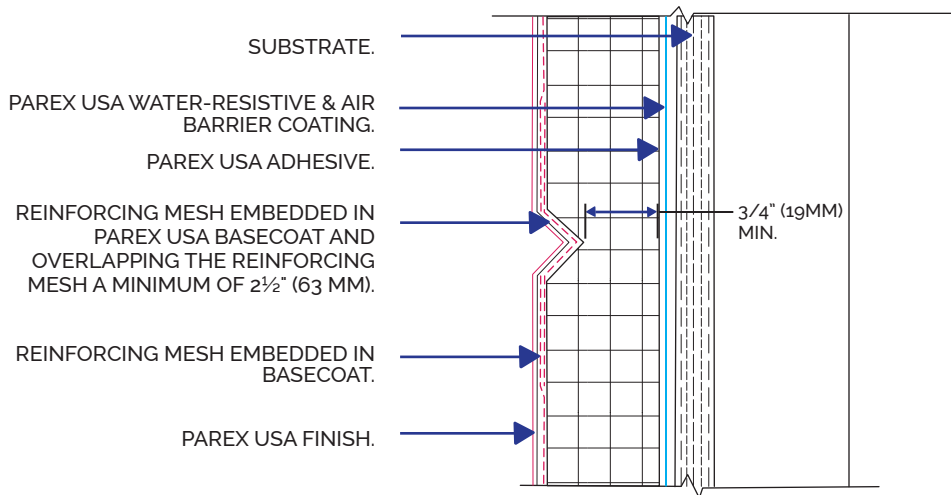
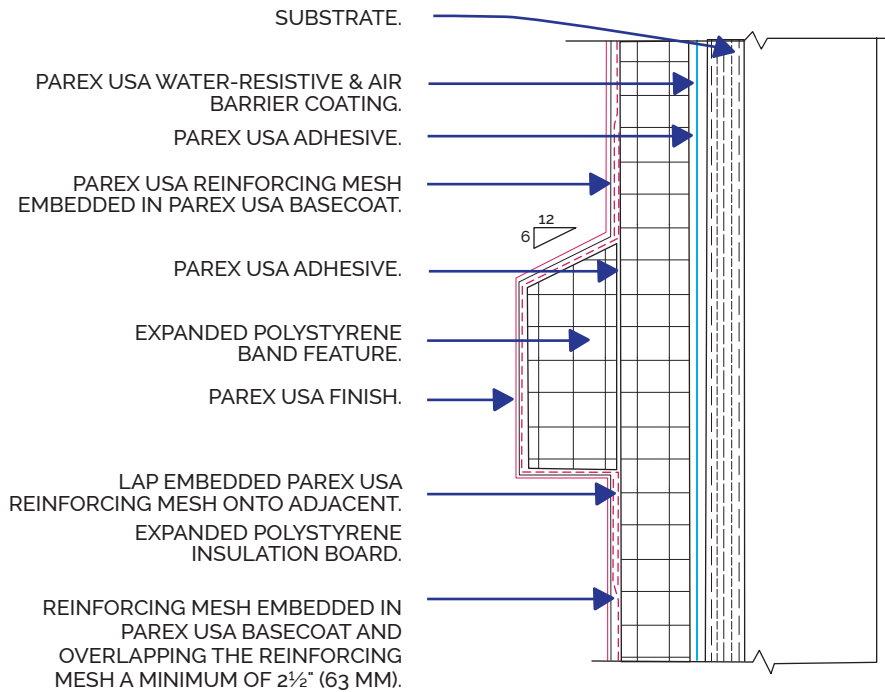

## SWM PA1.01 AESTHETIC BAND AND REVEAL

REV. DATE: 05/04/18

NOTES: 1. To ensure a continuous air barrier across the building envelope, a continuous air seal should be made at each substrate change, joints/gaps, penetrations and dissimilar material terminations. These must be a consideration of the designer in the overall wall assembly design.

**Disclaimer:** The design specifications and construction shall comply with all local building codes and standards. Parex USA installation guidelines are for general information and guidance only and Parex USA specifically disclaims any liability for the use of this design and for design engineering or workmanship of any project. The assembly shall be designed to prevent condensation within the assembly. The designer and the user shall provide final drawings and specifications. Products shown other than those manufactured by Parex USA are shown for clarity of the Parex USA product only. Contact the manufacturer of such other products for installation instructions.



## WATERMASTER CI

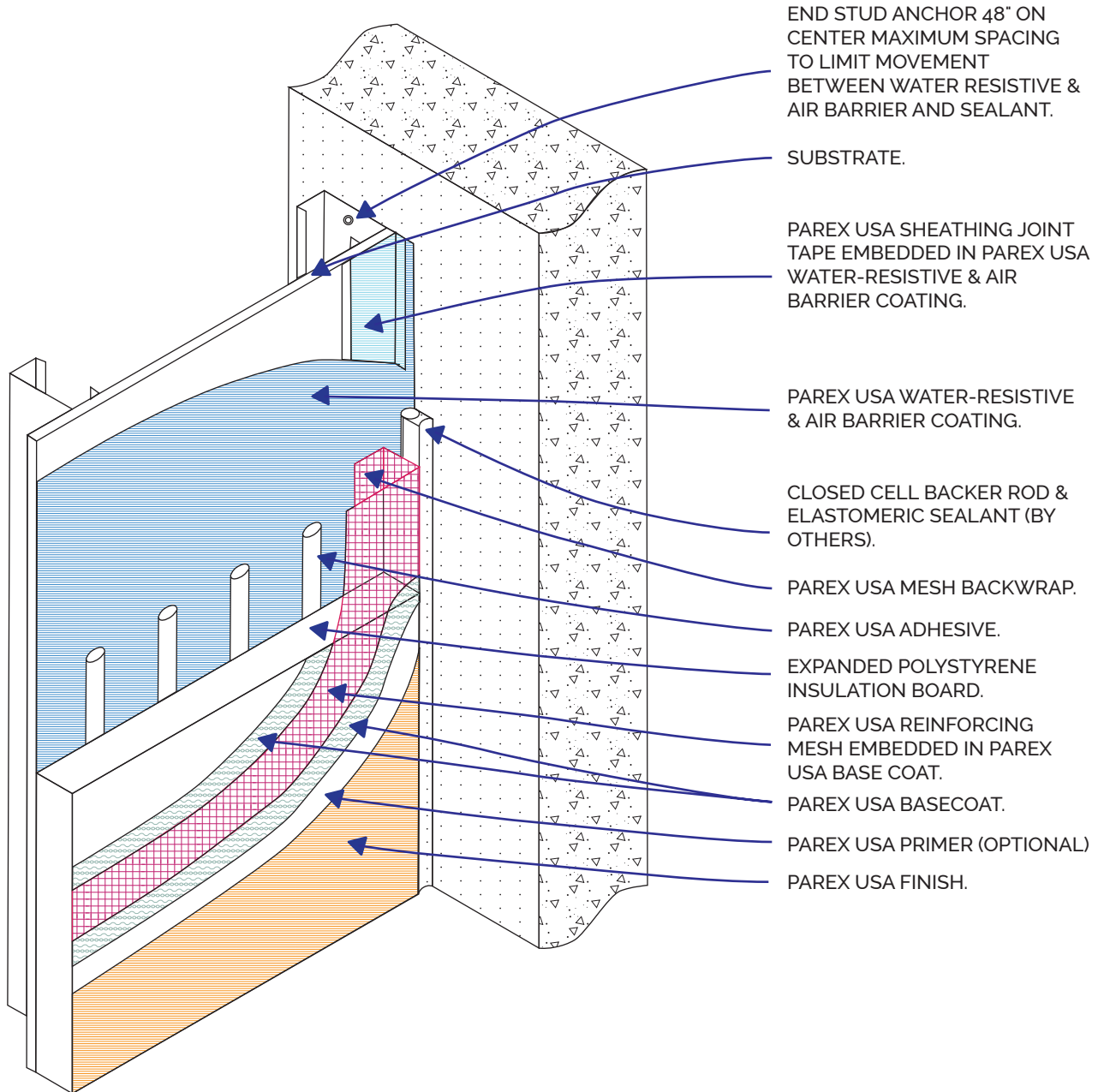

END STUD ANCHOR 48" ON CENTER MAXIMUM SPACING TO LIMIT MOVEMENT BETWEEN WATER RESISTIVE & AIR BARRIER AND SEALANT.

SUBSTRATE.

PAREX USA SHEATHING JOINT TAPE EMBEDDED IN PAREX USA WATER-RESISTIVE & AIR BARRIER COATING.

PAREX USA WATER-RESISTIVE & AIR BARRIER COATING.

CLOSED CELL BACKER ROD & ELASTOMERIC SEALANT (BY OTHERS).

PAREX USA MESH BACKWRAP.

PAREX USA ADHESIVE.

EXPANDED POLYSTYRENE INSULATION BOARD.

PAREX USA REINFORCING MESH EMBEDDED IN PAREX USA BASE COAT.

PAREX USA BASECOAT.

PAREX USA PRIMER (OPTIONAL)

PAREX USA FINISH.

## SWM E1.01 INSIDE CORNER TERMINATION

REV. DATE: 05/04/18

NOTES: 1. To ensure a continuous air barrier across the building envelope, a continuous air seal should be made at each substrate change, joints/gaps, penetrations and dissimilar material terminations. These must be a consideration of the designer in the overall wall assembly design.

**Disclaimer:** The design specifications and construction shall comply with all local building codes and standards. Parex USA installation guidelines are for general information and guidance only and Parex USA specifically disclaims any liability for the use of this design and for design engineering or workmanship of any project. The assembly shall be designed to prevent condensation within the assembly. The designer and the user shall provide final drawings and specifications. Products shown other than those manufactured by Parex USA are shown for clarity of the Parex USA product only. Contact the manufacturer of such other products for installation instructions.

## WATERMASTER CI

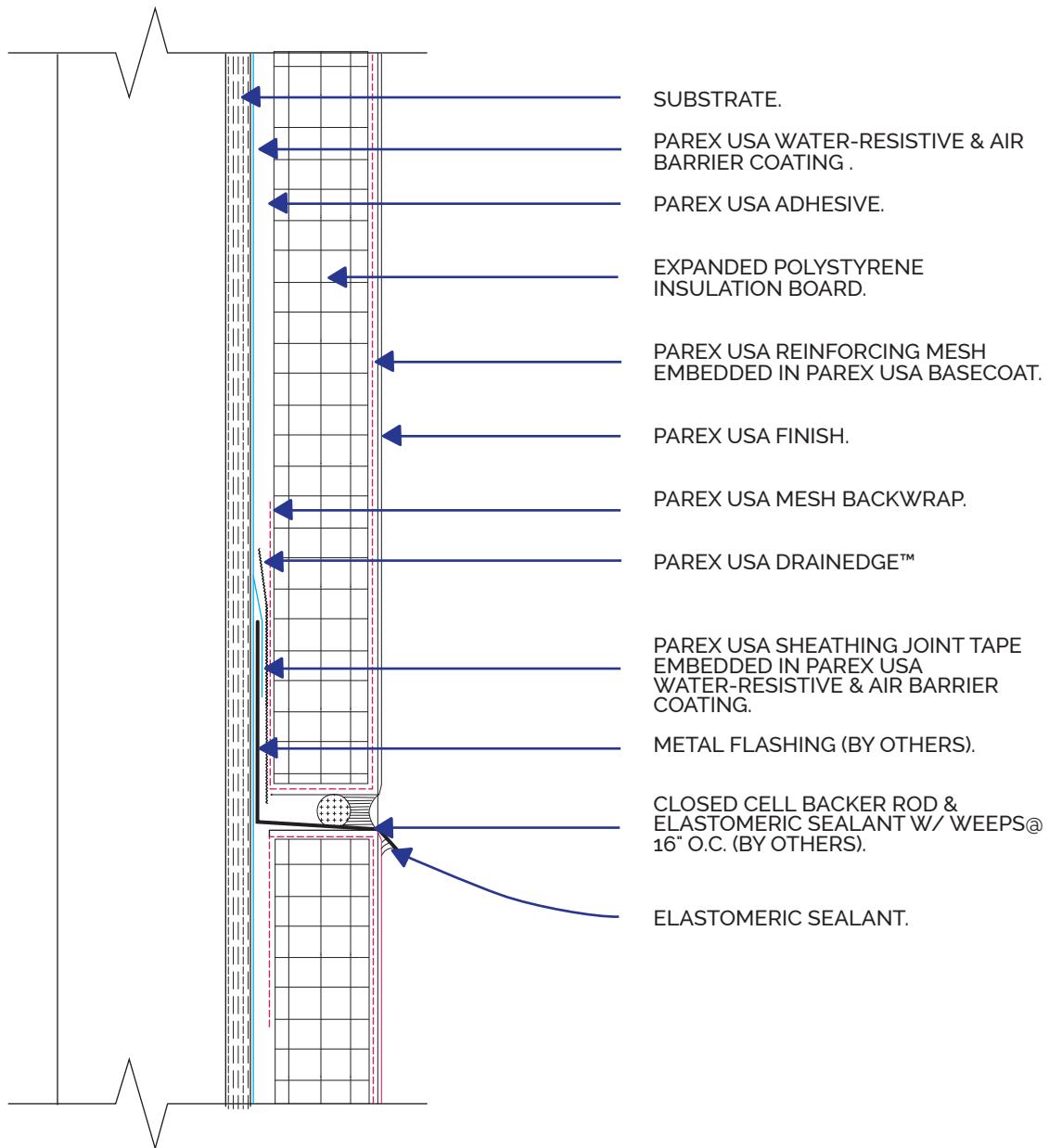

## SWM E1.02 THRU-SYSTEM FLASHING W/ WEEPS

REV. DATE: 05/04/18

NOTES: 1. To ensure a continuous air barrier across the building envelope, a continuous air seal should be made at each substrate change, joints/gaps, penetrations and dissimilar material terminations. These must be a consideration of the designer in the overall wall assembly design.

**Disclaimer:** The design specifications and construction shall comply with all local building codes and standards. Parex USA installation guidelines are for general information and guidance only and Parex USA specifically disclaims any liability for the use of this design and for design engineering or workmanship of any project. The assembly shall be designed to prevent condensation within the assembly. The designer and the user shall provide final drawings and specifications. Products shown other than those manufactured by Parex USA are shown for clarity of the Parex USA product only. Contact the manufacturer of such other products for installation instructions.

## WATERMASTER CI

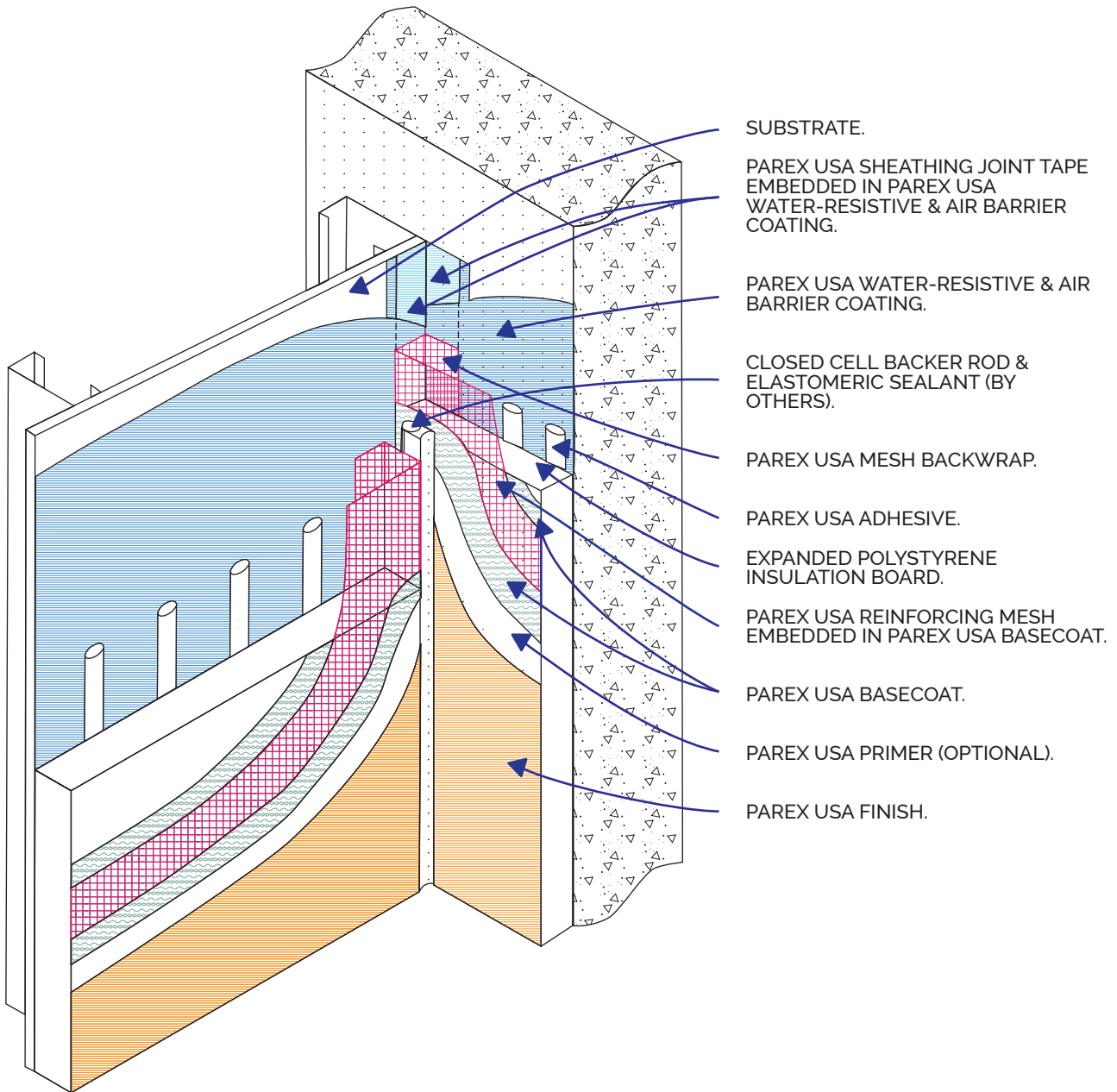

## SWM E1.03 EXPANSION JOINT AT DISSIMILAR SUBSTRATE

REV. DATE: 05/04/18

NOTES: 1. To ensure a continuous air barrier across the building envelope, a continuous air seal should be made at each substrate change, joints/gaps, penetrations and dissimilar material terminations. These must be a consideration of the designer in the overall wall assembly design.

**Disclaimer:** The design specifications and construction shall comply with all local building codes and standards. Parex USA installation guidelines are for general information and guidance only and Parex USA specifically disclaims any liability for the use of this design and for design engineering or workmanship of any project. The assembly shall be designed to prevent condensation within the assembly. The designer and the user shall provide final drawings and specifications. Products shown other than those manufactured by Parex USA are shown for clarity of the Parex USA product only. Contact the manufacturer of such other products for installation instructions.

## WATERMASTER CI

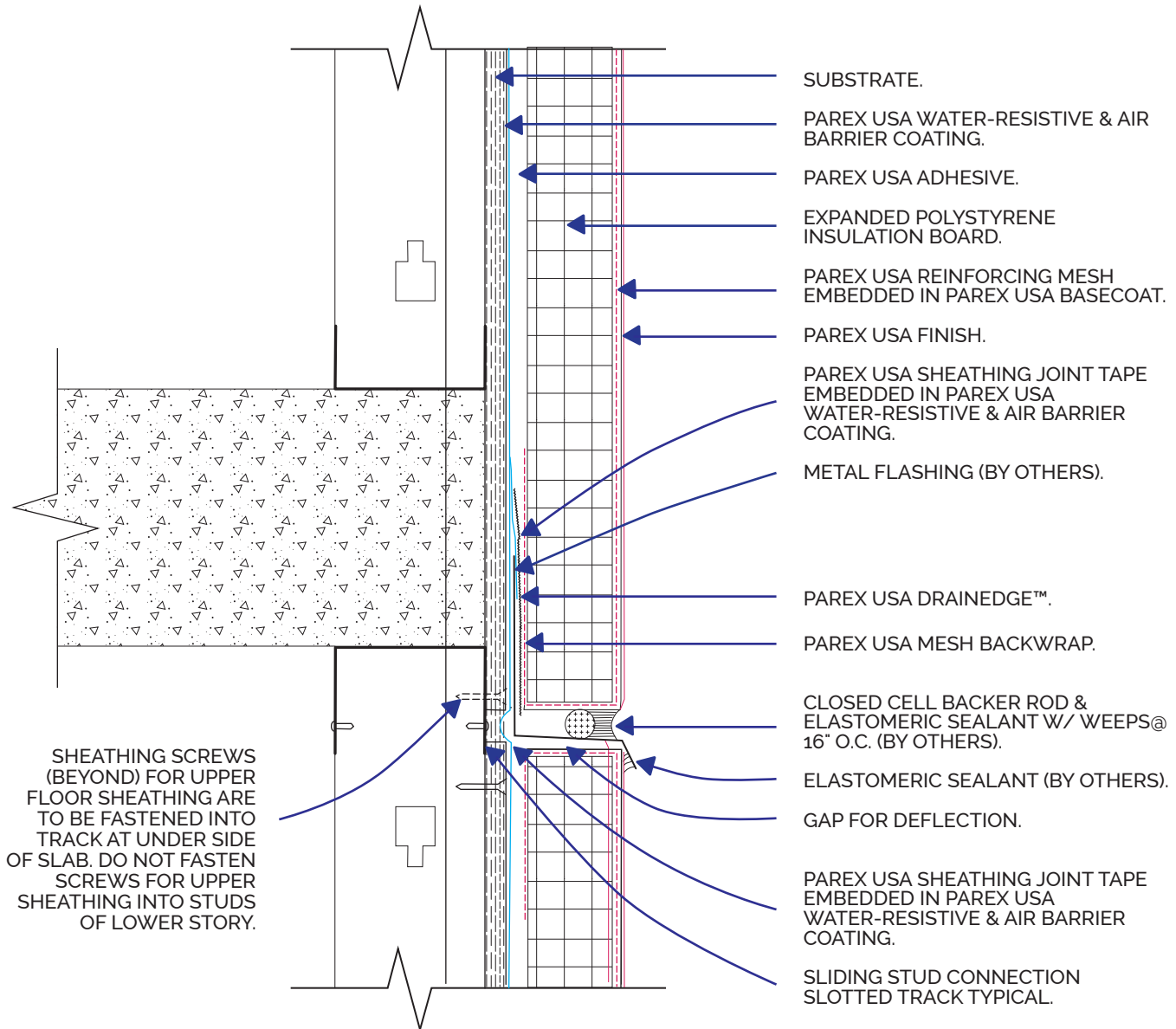

## SWM E1.04A FLOOR LINE DEFLECTION SLIP JOINT (2D)

REV. DATE: 05/04/18

NOTES: 1. To ensure a continuous air barrier across the building envelope, a continuous air seal should be made at each substrate change, joints/gaps, penetrations and dissimilar material terminations. These must be a consideration of the designer in the overall wall assembly design.

**Disclaimer:** The design specifications and construction shall comply with all local building codes and standards. Parex USA installation guidelines are for general information and guidance only and Parex USA specifically disclaims any liability for the use of this design and for design engineering or workmanship of any project. The assembly shall be designed to prevent condensation within the assembly. The designer and the user shall provide final drawings and specifications. Products shown other than those manufactured by Parex USA are shown for clarity of the Parex USA product only. Contact the manufacturer of such other products for installation instructions.

## WATERMASTER CI

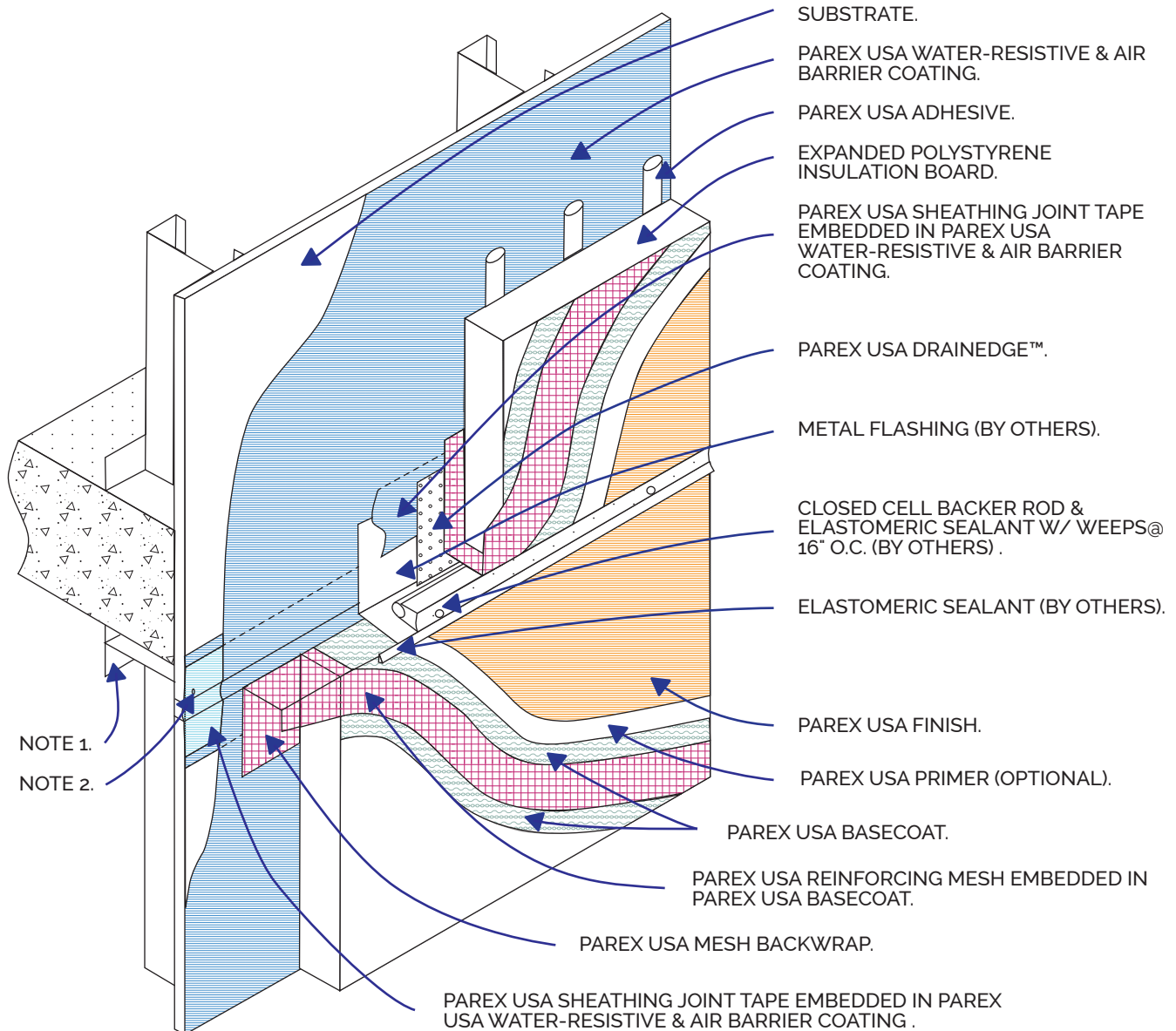

NOTE 1.

NOTE 2.

### SWM E1.04B FLOOR LINE DEFLECTION SLIP JOINT (ISO)

REV. DATE: 05/04/18

- NOTES: 1. To ensure a continuous air barrier across the building envelope, a continuous air seal should be made at each substrate change, joints/gaps, penetrations and dissimilar material terminations. These must be a consideration of the designer in the overall wall assembly design.
2. Sliding stud connection. Slotted track typical.
3. Sheathing screws for upper floor sheathing are to be fastened into track at under side of slab. Do not fasten screws for upper sheathing into studs of lower story.
4. CAUTION: If nested double tracks are used for deflection, sheathing screws must not interfere with track sliding

**Disclaimer:** The design specifications and construction shall comply with all local building codes and standards. Parex USA installation guidelines are for general information and guidance only and Parex USA specifically disclaims any liability for the use of this design and for design engineering or workmanship of any project. The assembly shall be designed to prevent condensation within the assembly. The designer and the user shall provide final drawings and specifications. Products shown other than those manufactured by Parex USA are shown for clarity of the Parex USA product only. Contact the manufacturer of such other products for installation instructions.

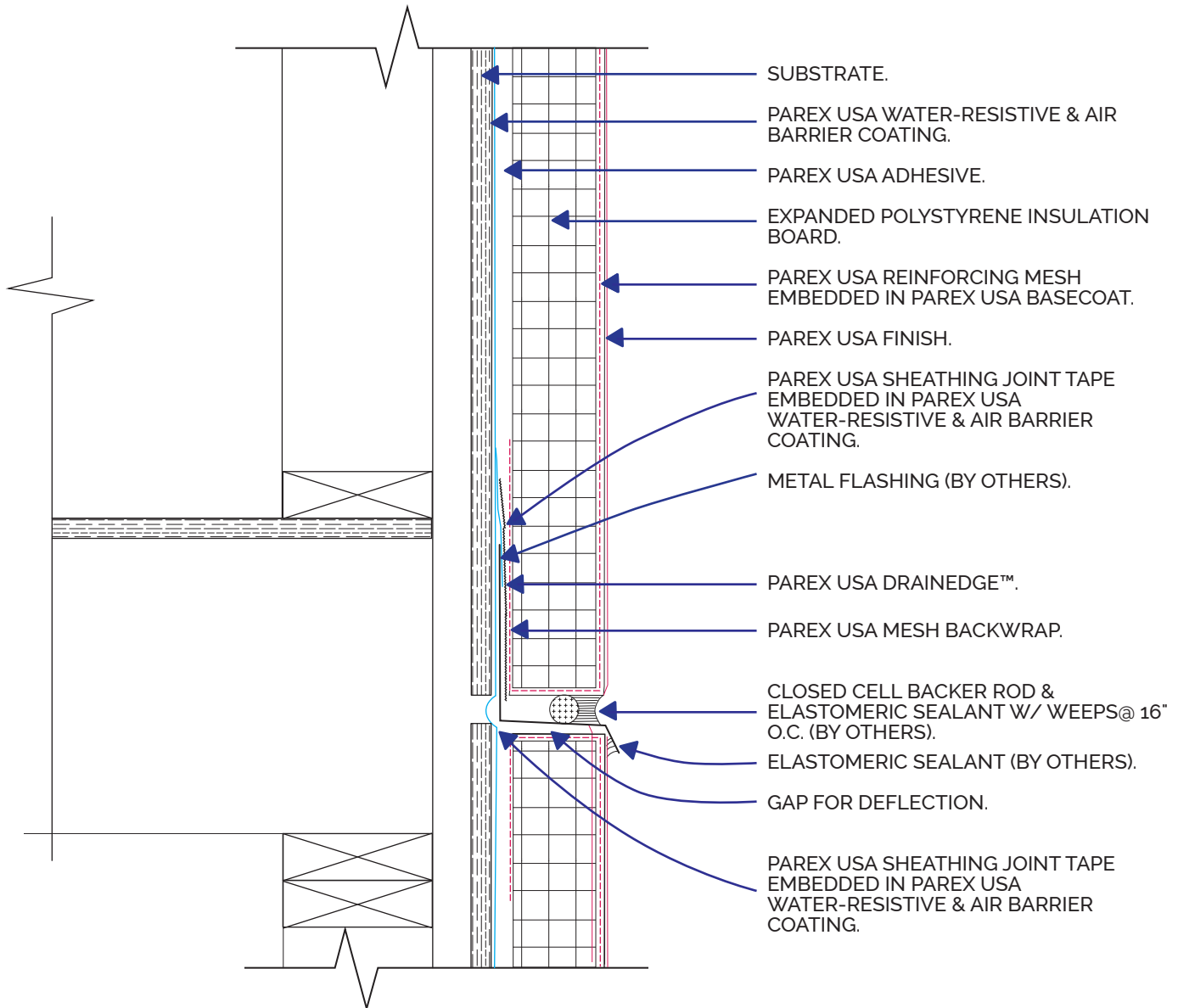

### SWM E1.05A EXPANSION JOINT WITH FLASHING AT FLOOR (2D)

REV. DATE: 05/04/18

NOTES: 1. To ensure a continuous air barrier across the building envelope, a continuous air seal should be made at each substrate change, joints/gaps, penetrations and dissimilar material terminations. These must be a consideration of the designer in the overall wall assembly design.

2. Framing shown in this drawing is only conceptual and is not for construction. Follow framing designer's requirements.

**Disclaimer:** The design specifications and construction shall comply with all local building codes and standards. Parex USA installation guidelines are for general information and guidance only and Parex USA specifically disclaims any liability for the use of this design and for design engineering or workmanship of any project. The assembly shall be designed to prevent condensation within the assembly. The designer and the user shall provide final drawings and specifications. Products shown other than those manufactured by Parex USA are shown for clarity of the Parex USA product only. Contact the manufacturer of such other products for installation instructions.

## WATERMASTER CI

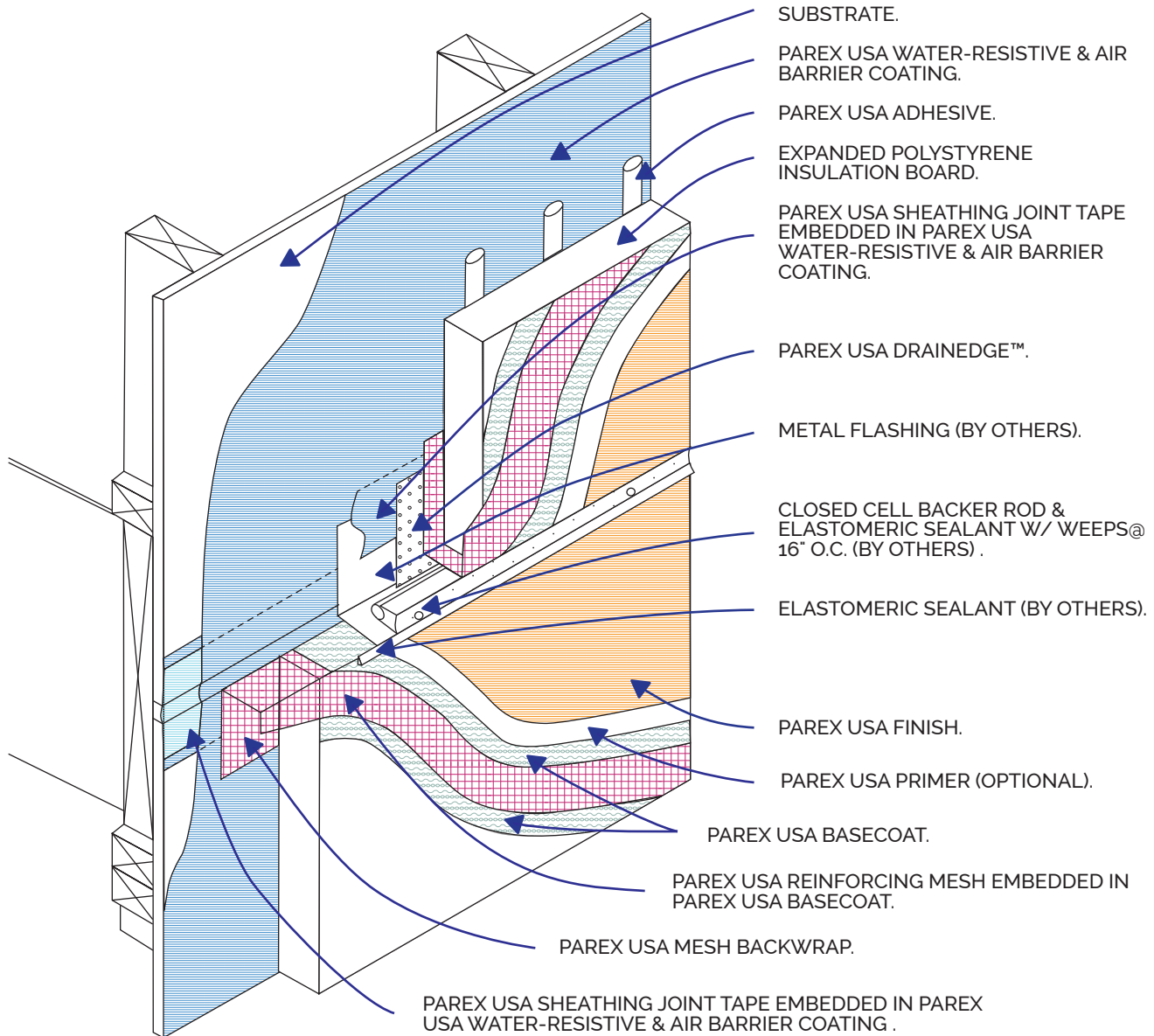

## SWM E1.05B EXPANSION JOINT WITH FLASHING AT FLOOR (ISO)

REV. DATE: 05/04/18

NOTES: 1. To ensure a continuous air barrier across the building envelope, a continuous air seal should be made at each substrate change, joints/gaps, penetrations and dissimilar material terminations. These must be a consideration of the designer in the overall wall assembly design.

**Disclaimer:** The design specifications and construction shall comply with all local building codes and standards. Parex USA installation guidelines are for general information and guidance only and Parex USA specifically disclaims any liability for the use of this design and for design engineering or workmanship of any project. The assembly shall be designed to prevent condensation within the assembly. The designer and the user shall provide final drawings and specifications. Products shown other than those manufactured by Parex USA are shown for clarity of the Parex USA product only. Contact the manufacturer of such other products for installation instructions.

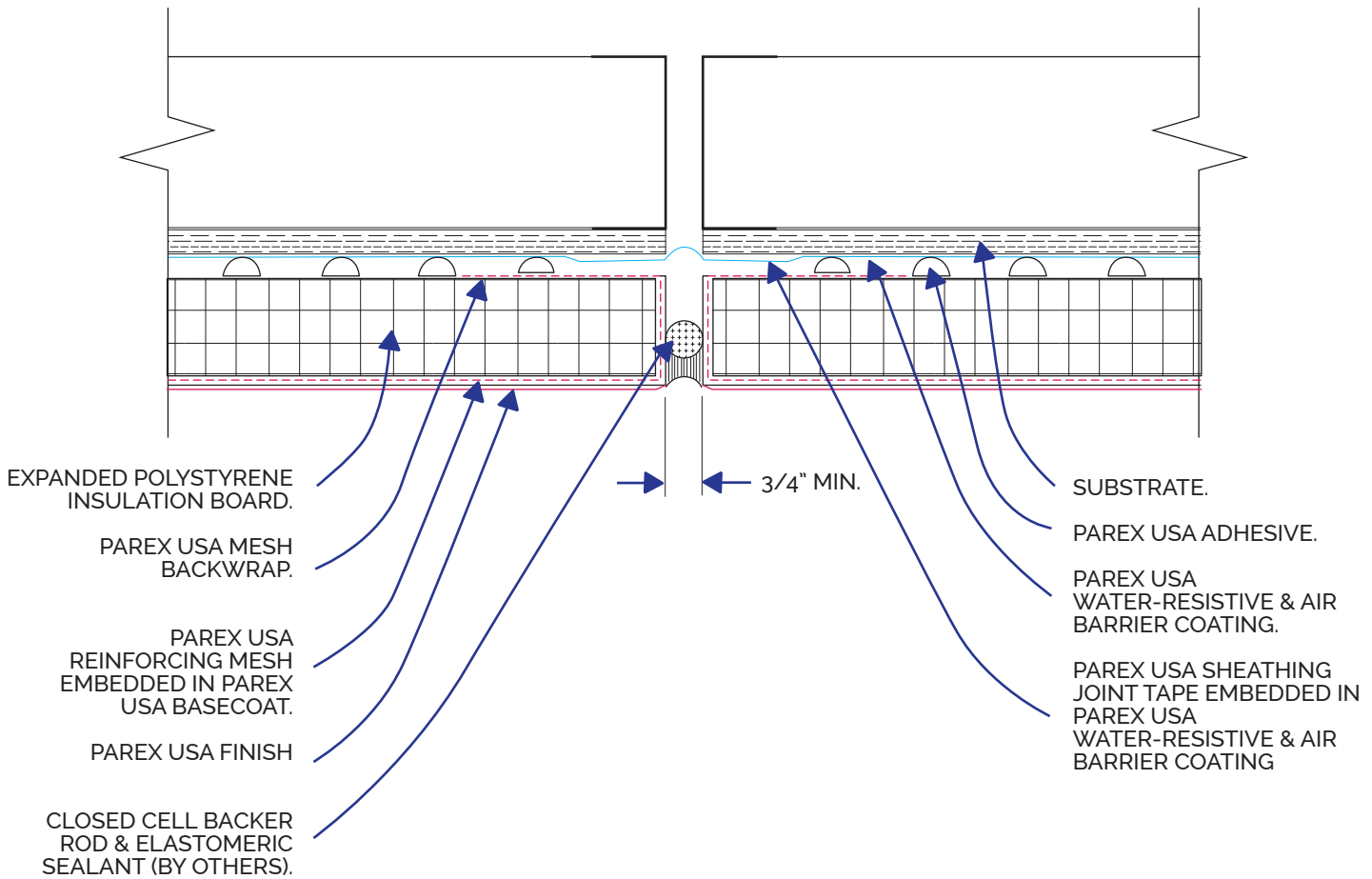

## SWM E1.06A VERTICAL EXPANSION JOINT

REV. DATE: 05/04/18

NOTES: 1. To ensure a continuous air barrier across the building envelope, a continuous air seal should be made at each substrate change, joints/gaps, penetrations and dissimilar material terminations. These must be a consideration of the designer in the overall wall assembly design.

**Disclaimer:** The design specifications and construction shall comply with all local building codes and standards. Parex USA installation guidelines are for general information and guidance only and Parex USA specifically disclaims any liability for the use of this design and for design engineering or workmanship of any project. The assembly shall be designed to prevent condensation within the assembly. The designer and the user shall provide final drawings and specifications. Products shown other than those manufactured by Parex USA are shown for clarity of the Parex USA product only. Contact the manufacturer of such other products for installation instructions.



## WATERMASTER CI

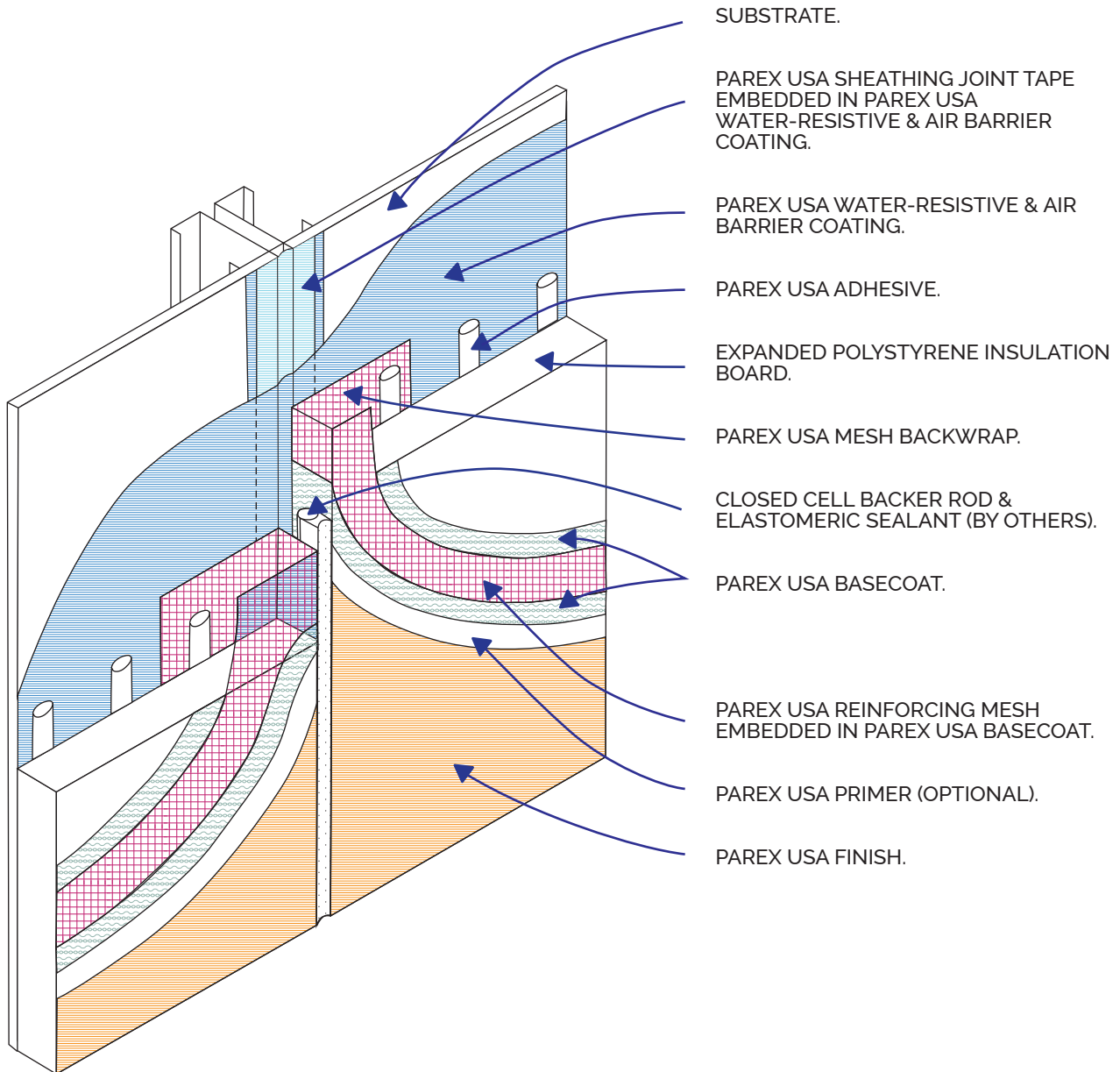

## SWM E1.06B VERTICAL EXPANSION JOINT

REV. DATE: 05/04/18

NOTES: 1. To ensure a continuous air barrier across the building envelope, a continuous air seal should be made at each substrate change, joints/gaps, penetrations and dissimilar material terminations. These must be a consideration of the designer in the overall wall assembly design.

**Disclaimer:** The design specifications and construction shall comply with all local building codes and standards. Parex USA installation guidelines are for general information and guidance only and Parex USA specifically disclaims any liability for the use of this design and for design engineering or workmanship of any project. The assembly shall be designed to prevent condensation within the assembly. The designer and the user shall provide final drawings and specifications. Products shown other than those manufactured by Parex USA are shown for clarity of the Parex USA product only. Contact the manufacturer of such other products for installation instructions.

## WATERMASTER CI

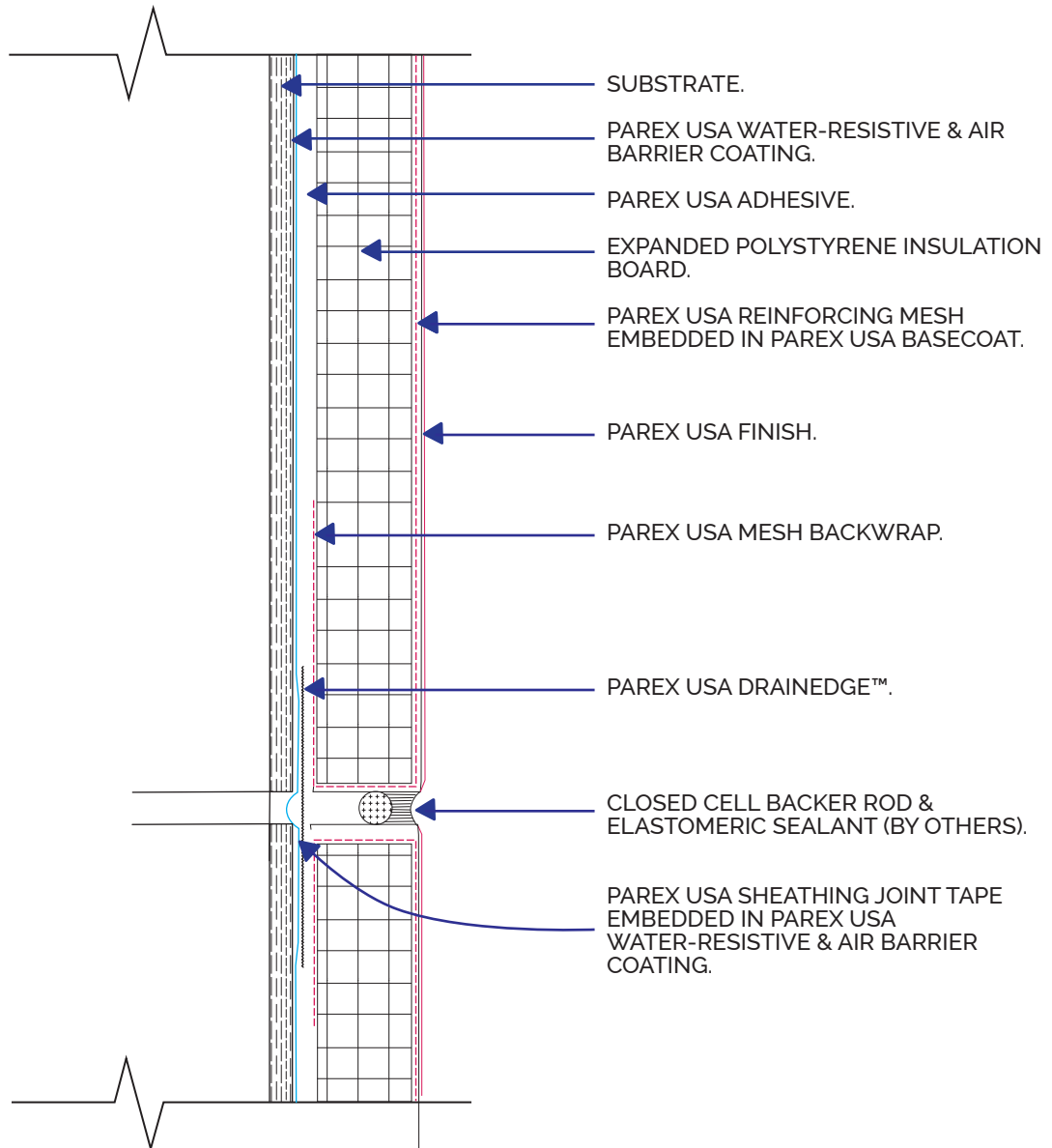

## SWM E1.07 HORIZONTAL EXPANSION JOINT

REV. DATE: 05/04/18

NOTES: 1. To ensure a continuous air barrier across the building envelope, a continuous air seal should be made at each substrate change, joints/gaps, penetrations and dissimilar material terminations. These must be a consideration of the designer in the overall wall assembly design.

**Disclaimer:** The design specifications and construction shall comply with all local building codes and standards. Parex USA installation guidelines are for general information and guidance only and Parex USA specifically disclaims any liability for the use of this design and for design engineering or workmanship of any project. The assembly shall be designed to prevent condensation within the assembly. The designer and the user shall provide final drawings and specifications. Products shown other than those manufactured by Parex USA are shown for clarity of the Parex USA product only. Contact the manufacturer of such other products for installation instructions.

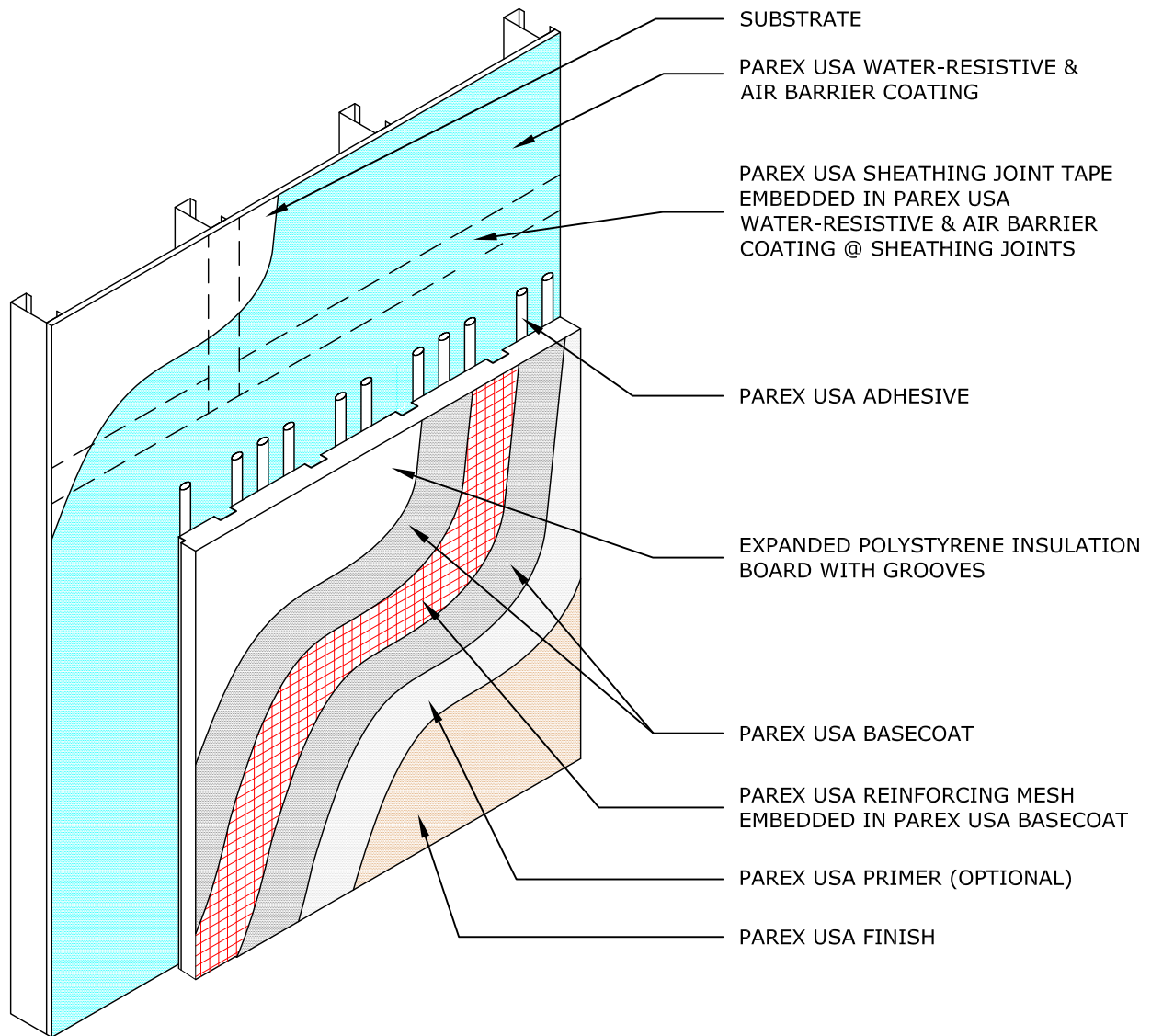

## SWM G1.01B PAREX STANDARD WATERMASTER-GX SYSTEM COMPONENTS

STANDARD WATERMASTER SYSTEM  
OPTIMUM WATERMASTER SYSTEM

- NOTE:
1. Applicable for wood framing, masonry and concrete also.
  2. SWM Details are applicable with the Grooved insulation boards
  3. See WeatherTech details for further information.

Disclaimer: The design, specifications, and construction shall comply with all local building codes and standards. Parex USA installation guidelines are for general information and guidance only and Parex USA specifically disclaims any liability for the use of this design, and for design, engineering, or workmanship of any project. The assembly shall be designed to prevent condensation within the assembly. The designer and the user shall provide final drawings and specifications. Products shown other than those manufactured by Parex USA are shown for clarity of the Parex USA product only. Contact the manufacturer of such other products for installation instructions.

## WATERMASTER CI

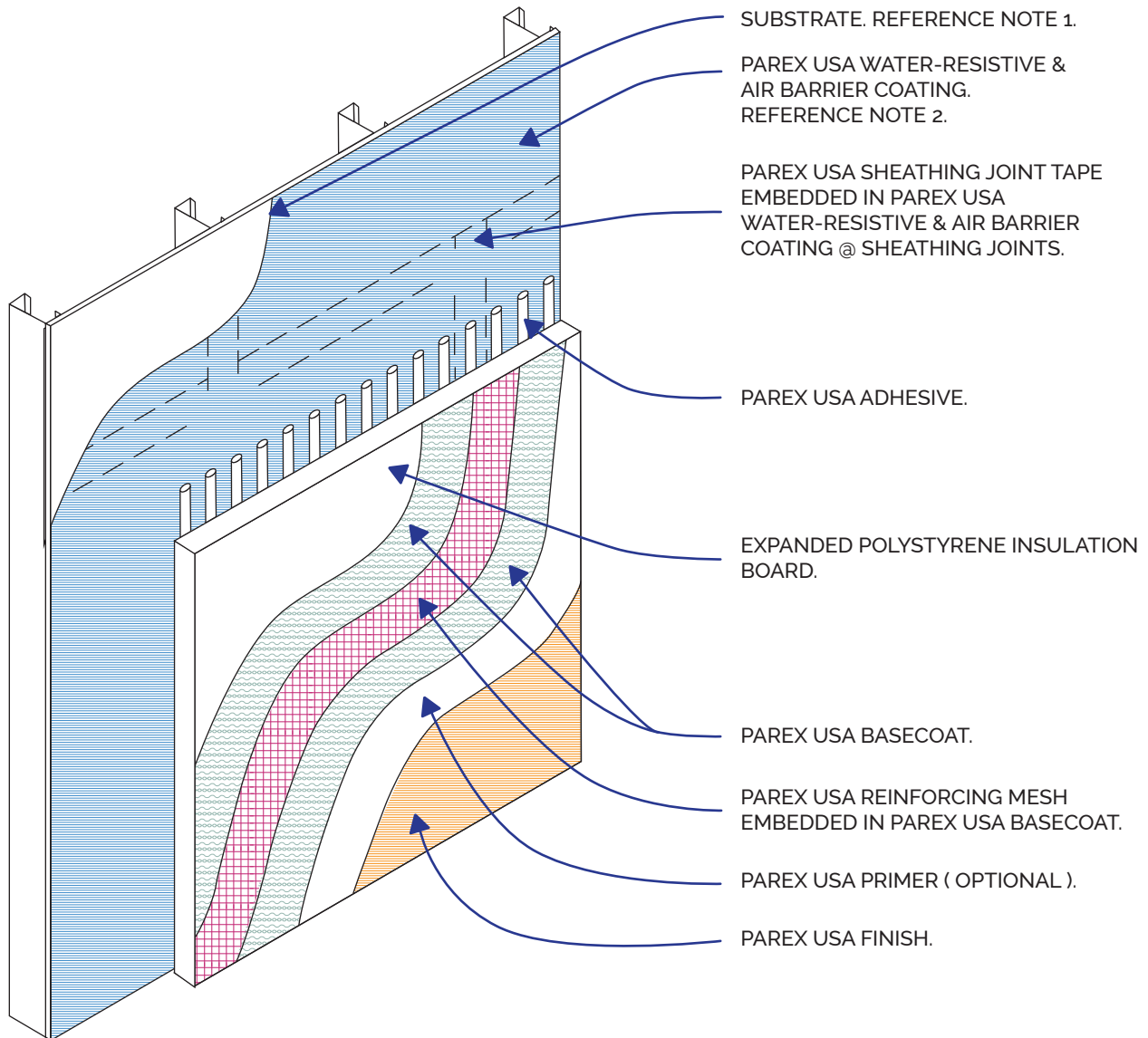

## SWM G1.01 PAREX USA WATERMASTER CI SYSTEM COMPONENTS

REV. DATE: 06/08/18

NOTES: 1. Applicable for wood framing, masonry and concrete.  
2. See WeatherTech details for further information.

**Disclaimer:** The design specifications and construction shall comply with all local building codes and standards. Parex USA installation guidelines are for general information and guidance only and Parex USA specifically disclaims any liability for the use of this design and for design engineering or workmanship of any project. The assembly shall be designed to prevent condensation within the assembly. The designer and the user shall provide final drawings and specifications. Products shown other than those manufactured by Parex USA are shown for clarity of the Parex USA product only. Contact the manufacturer of such other products for installation instructions.

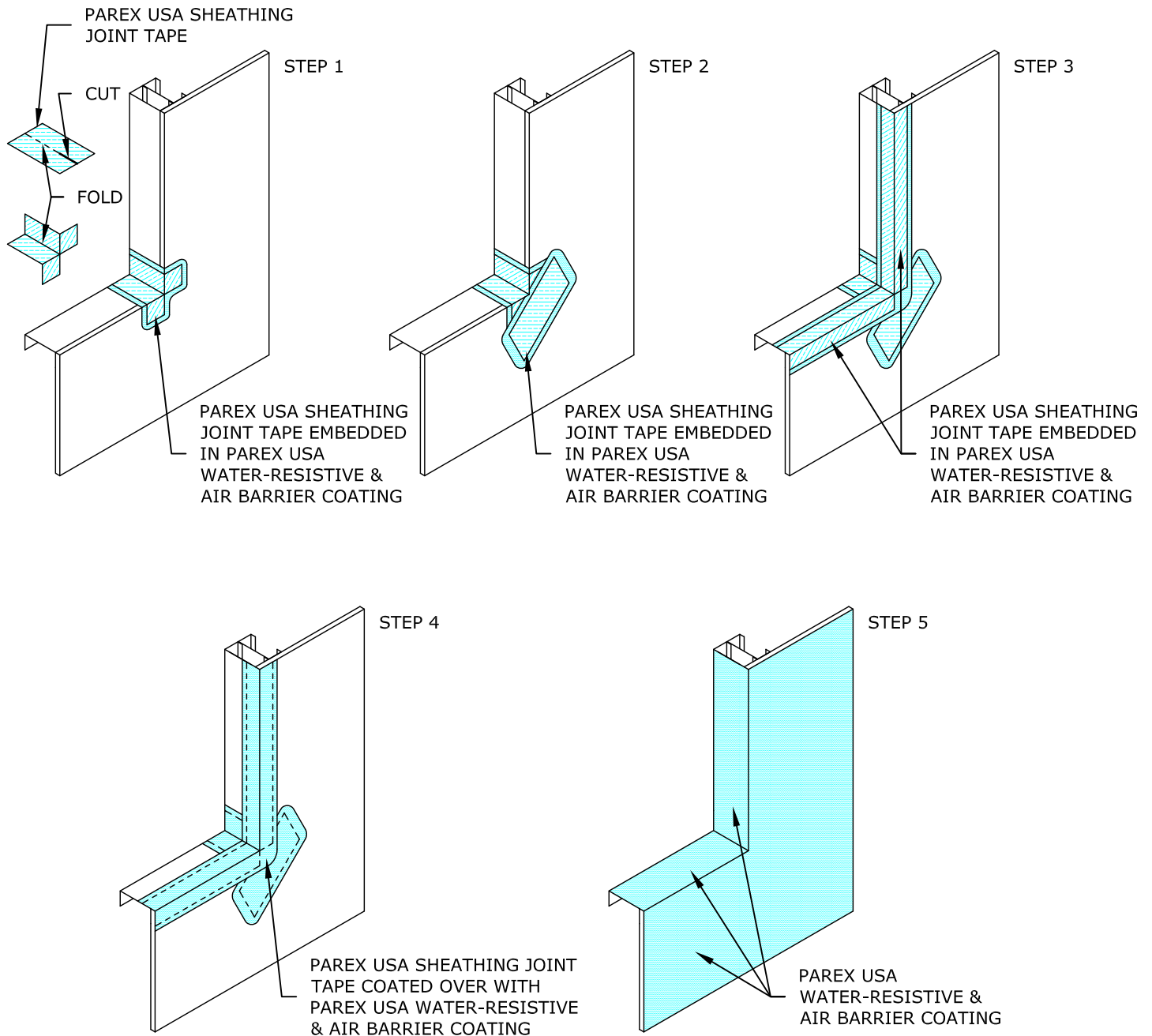

## SWM G1.03A ROUGH OPENING FLASHING PROCEDURE (HEAD IS SIMILAR)

STANDARD WATERMASTER SYSTEM  
OPTIMUM WATERMASTER SYSTEM

- NOTE:**
1. Head flashing procedure similar.
  2. To ensure a continuous air barrier across the building envelope, a continuous air seal should be made at each substrate change, joints/gaps, penetrations and dissimilar material terminations. These must be a consideration of the designer in the overall wall assembly design.

Disclaimer: The design, specifications, and construction shall comply with all local building codes and standards. Parex USA installation guidelines are for general information and guidance only and Parex USA specifically disclaims any liability for the use of this design, and for design, engineering, or workmanship of any project. The assembly shall be designed to prevent condensation within the assembly. The designer and the user shall provide final drawings and specifications. Products shown other than those manufactured by Parex USA are shown for clarity of the Parex USA product only. Contact the manufacturer of such other products for installation instructions.

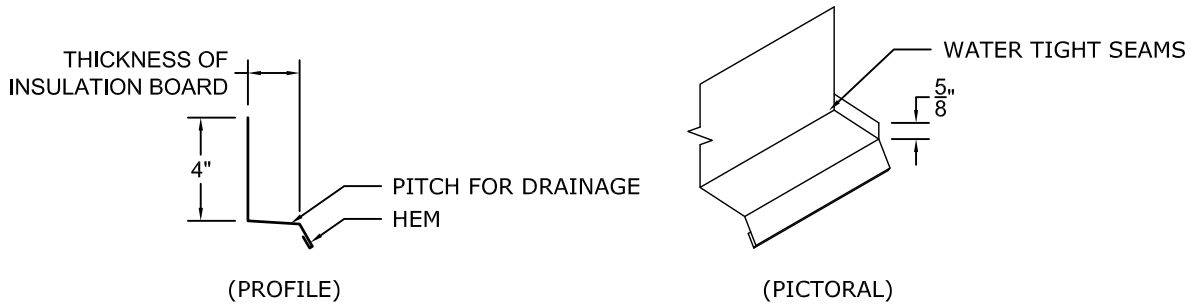

METAL HEAD FLASHING PROFILE

HEAD FLASHING SHOULD BE FABRICATED IN THE PROFILE SHOWN. LENGTH OF FLASHING IS 1" LONGER THAN THE WIDTH OF THE WINDOW FRAME. END DAMS SHOULD BE TURNED UPWARD 5/8" AS SHOWN.

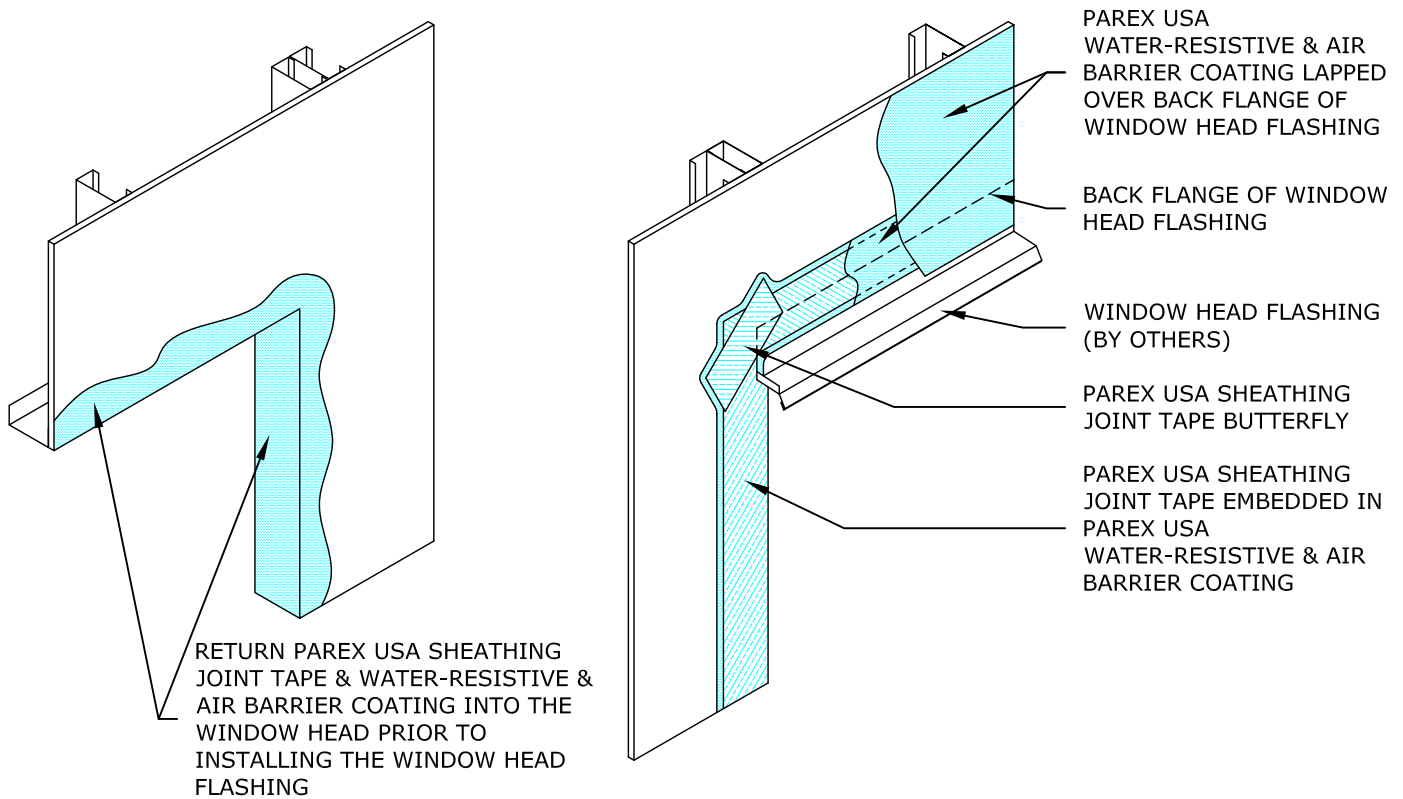

## SWM G1.03B ROUGH OPENING FLASHING PROCEDURE CONTINUED

STANDARD WATERMASTER SYSTEM  
OPTIMUM WATERMASTER SYSTEM

- NOTE:
1. To ensure a continuous air barrier across the building envelope, a continuous air seal should be made at each substrate change, joints/gaps, penetrations and dissimilar material terminations. These must be a consideration of the designer in the overall wall assembly design.
  2. Finned window frames are installed before head flashing.
  3. Do not use plastic track at window heads.

Disclaimer: The design, specifications, and construction shall comply with all local building codes and standards. Parex USA installation guidelines are for general information and guidance only and Parex USA specifically disclaims any liability for the use of this design, and for design, engineering, or workmanship of any project. The assembly shall be designed to prevent condensation within the assembly. The designer and the user shall provide final drawings and specifications. Products shown other than those manufactured by Parex USA are shown for clarity of the Parex USA product only. Contact the manufacturer of such other products for installation instructions.

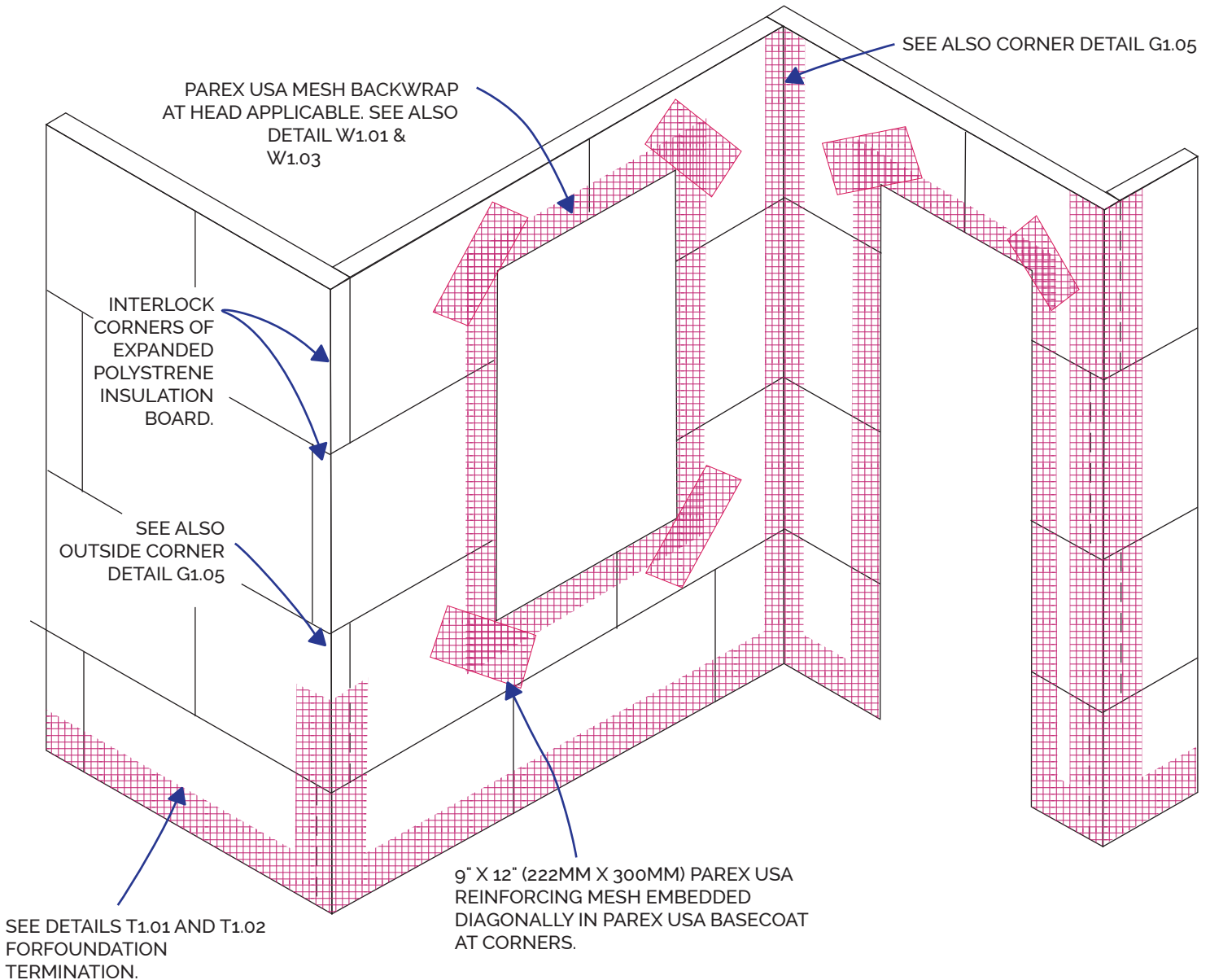

### SWM G1.04 PRELIMINARY MESH APPLICATION

REV. DATE: 05/04/18

NOTES: 1. Expanded polystyrene insulation board joints are offset from with corners of openings.

**Disclaimer:** The design specifications and construction shall comply with all local building codes and standards. Parex USA installation guidelines are for general information and guidance only and Parex USA specifically disclaims any liability for the use of this design and for design engineering or workmanship of any project. The assembly shall be designed to prevent condensation within the assembly. The designer and the user shall provide final drawings and specifications. Products shown other than those manufactured by Parex USA are shown for clarity of the Parex USA product only. Contact the manufacturer of such other products for installation instructions.

## WATERMASTER CI

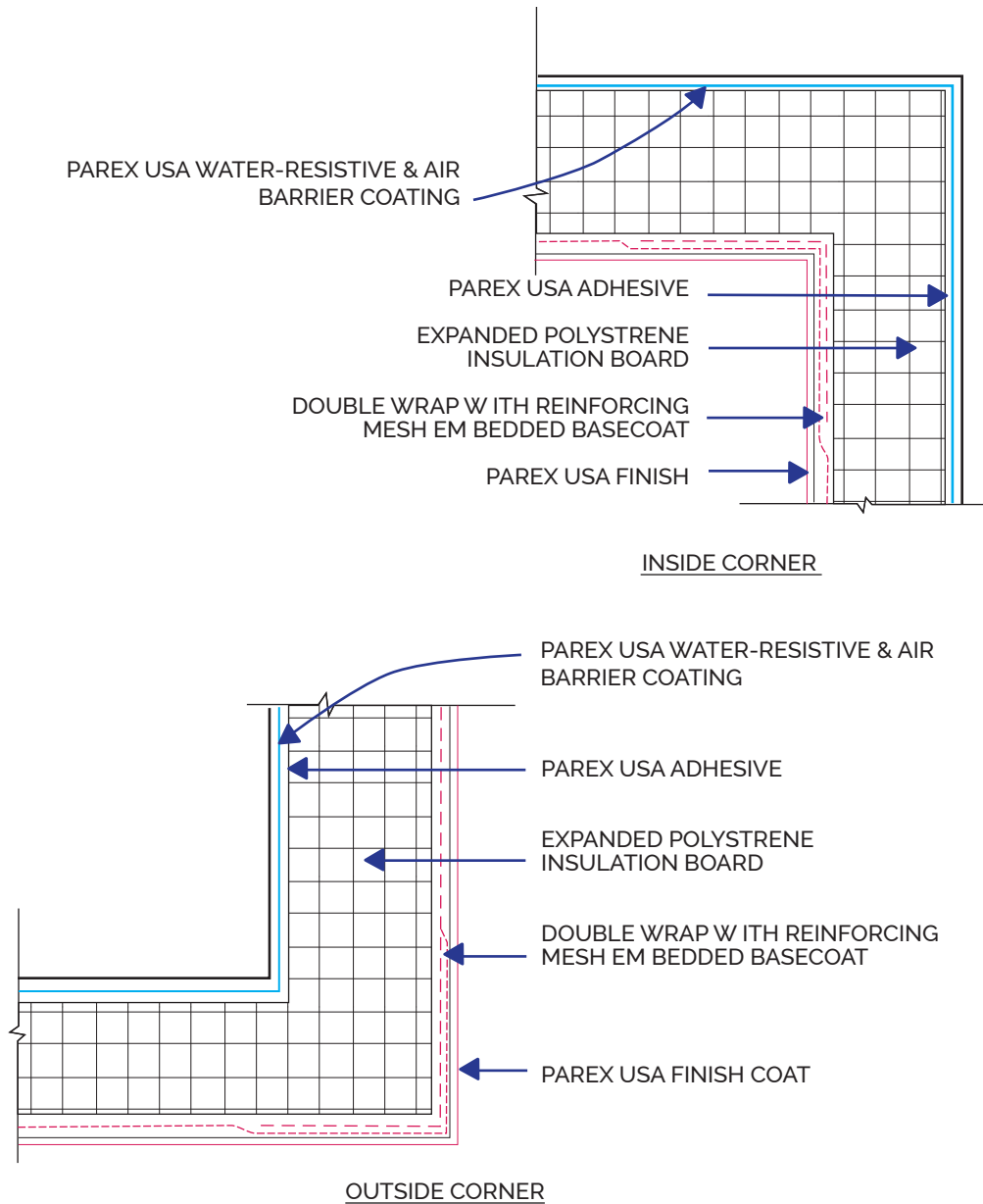

### SWM G1.05 INSIDE AND OUTSIDE CORNERS

REV. DATE: 05/04/18

NOTES: 1. To ensure a continuous air barrier across the building envelope, a continuous air seal should be made at each substrate change, joints/gaps, penetrations and dissimilar material terminations. These must be a consideration of the designer in the overall wall assembly design.

**Disclaimer:** The design specifications and construction shall comply with all local building codes and standards. Parex USA installation guidelines are for general information and guidance only and Parex USA specifically disclaims any liability for the use of this design and for design engineering or workmanship of any project. The assembly shall be designed to prevent condensation within the assembly. The designer and the user shall provide final drawings and specifications. Products shown other than those manufactured by Parex USA are shown for clarity of the Parex USA product only. Contact the manufacturer of such other products for installation instructions.



## WATERMASTER CI

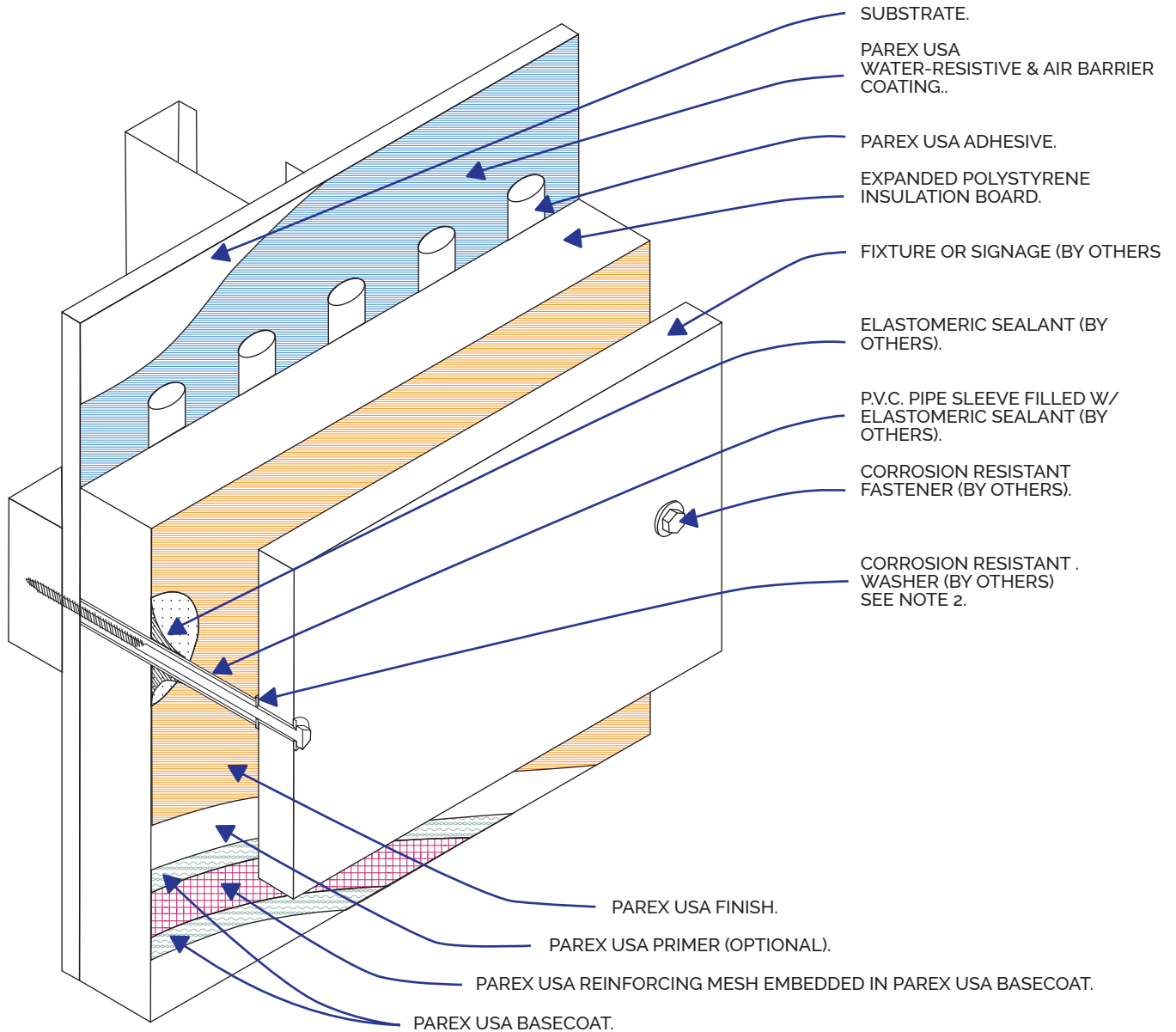

### SWM P1.01 FIXTURE ATTACHMENT (BY OTHERS)

REV. DATE: 05/04/18

NOTES: 1. To ensure a continuous air barrier across the building envelope, a continuous air seal should be made at each substrate change, joints/gaps, penetrations and dissimilar material terminations. These must be a consideration of the designer in the overall wall assembly design.

**Disclaimer:** The design specifications and construction shall comply with all local building codes and standards. Parex USA installation guidelines are for general information and guidance only and Parex USA specifically disclaims any liability for the use of this design and for design engineering or workmanship of any project. The assembly shall be designed to prevent condensation within the assembly. The designer and the user shall provide final drawings and specifications. Products shown other than those manufactured by Parex USA are shown for clarity of the Parex USA product only. Contact the manufacturer of such other products for installation instructions.

## WATERMASTER CI

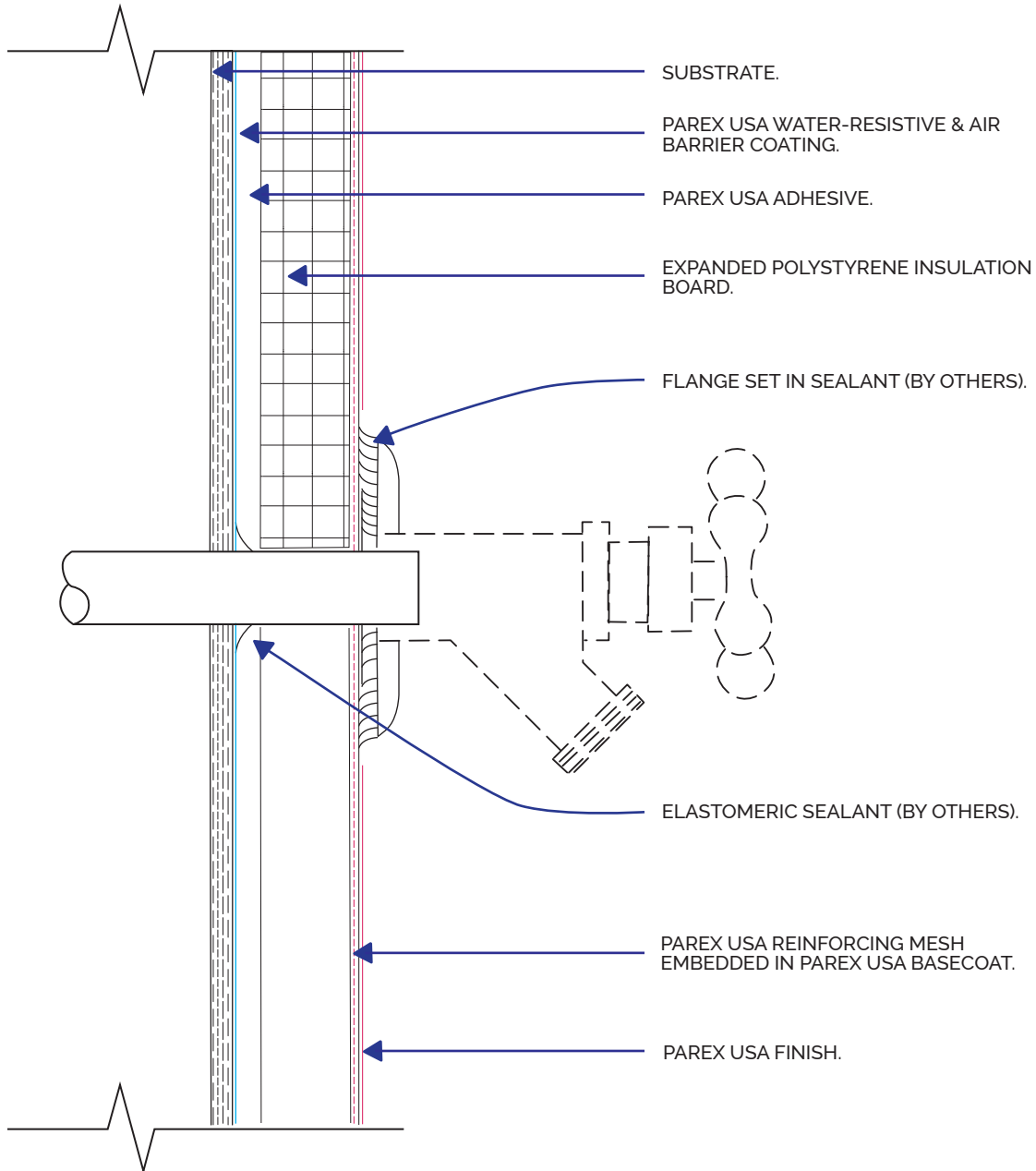

## SWM P1.02 TERMINATION AT HOSE BIB (BY OTHERS)

REV. DATE: 05/04/18

NOTES: 1. To ensure a continuous air barrier across the building envelope, a continuous air seal should be made at each substrate change, joints/gaps, penetrations and dissimilar material terminations. These must be a consideration of the designer in the overall wall assembly design.

**Disclaimer:** The design specifications and construction shall comply with all local building codes and standards. Parex USA installation guidelines are for general information and guidance only and Parex USA specifically disclaims any liability for the use of this design and for design engineering or workmanship of any project. The assembly shall be designed to prevent condensation within the assembly. The designer and the user shall provide final drawings and specifications. Products shown other than those manufactured by Parex USA are shown for clarity of the Parex USA product only. Contact the manufacturer of such other products for installation instructions.

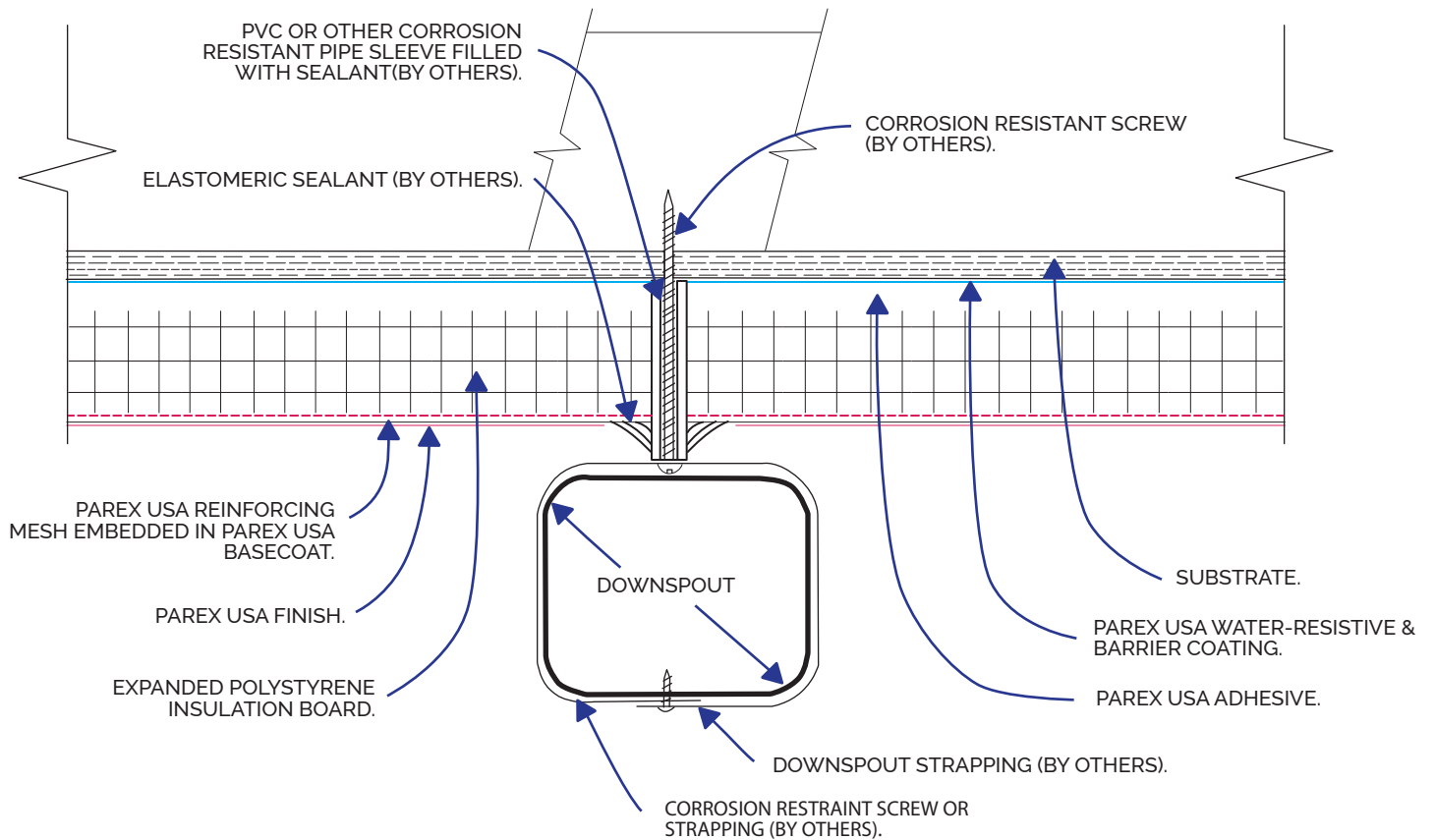

### SWM P1.03 DOWNNSPOUT ATTACHMENT (BY OTHERS)

REV. DATE: 05/04/18

NOTES: 1. To ensure a continuous air barrier across the building envelope, a continuous air seal should be made at each substrate change, joints/gaps, penetrations and dissimilar material terminations. These must be a consideration of the designer in the overall wall assembly design.

**Disclaimer:** The design specifications and construction shall comply with all local building codes and standards. Parex USA installation guidelines are for general information and guidance only and Parex USA specifically disclaims any liability for the use of this design and for design engineering or workmanship of any project. The assembly shall be designed to prevent condensation within the assembly. The designer and the user shall provide final drawings and specifications. Products shown other than those manufactured by Parex USA are shown for clarity of the Parex USA product only. Contact the manufacturer of such other products for installation instructions.

## WATERMASTER CI

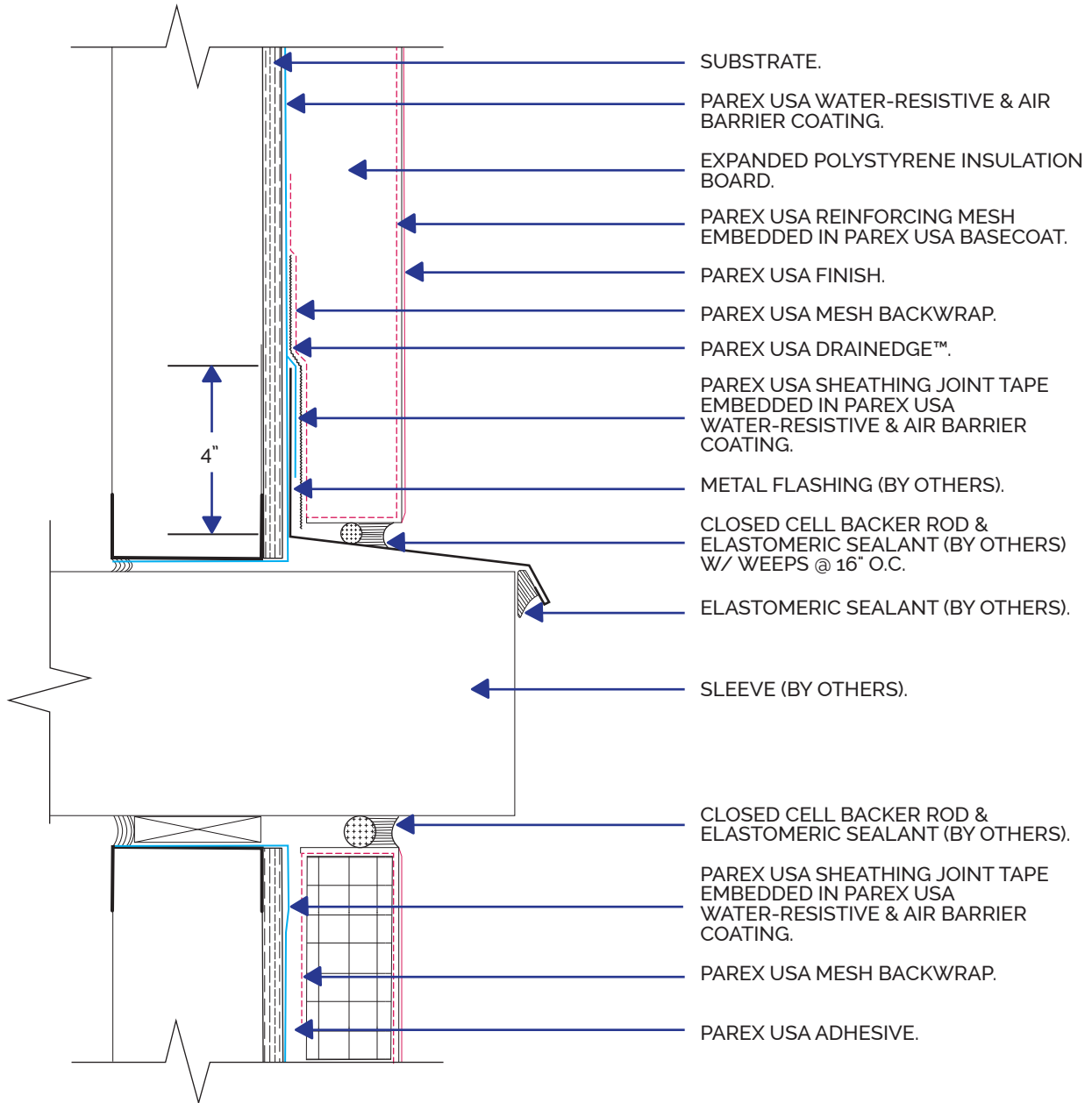

### SWM P1.04 TERMINATION AT APPLIANCE SLEEVE (BY OTHERS)

REV. DATE: 05/04/18

NOTES: 1. To ensure a continuous air barrier across the building envelope, a continuous air seal should be made at each substrate change, joints/gaps, penetrations and dissimilar material terminations. These must be a consideration of the designer in the overall wall assembly design.

**Disclaimer:** The design specifications and construction shall comply with all local building codes and standards. Parex USA installation guidelines are for general information and guidance only and Parex USA specifically disclaims any liability for the use of this design and for design engineering or workmanship of any project. The assembly shall be designed to prevent condensation within the assembly. The designer and the user shall provide final drawings and specifications. Products shown other than those manufactured by Parex USA are shown for clarity of the Parex USA product only. Contact the manufacturer of such other products for installation instructions.

## WATERMASTER CI

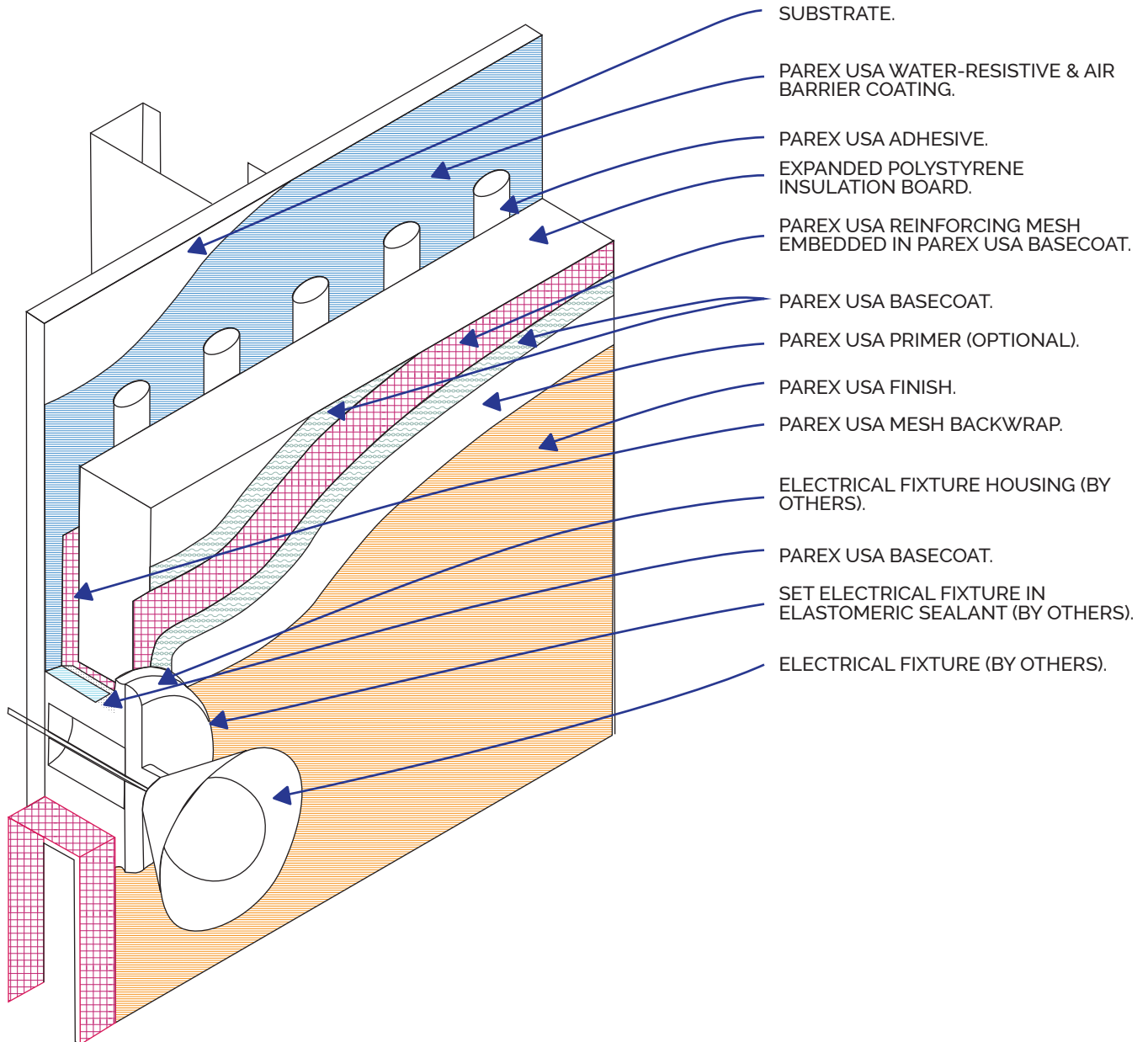

- SUBSTRATE.
- PAREX USA WATER-RESISTIVE & AIR BARRIER COATING.
- PAREX USA ADHESIVE.
- EXPANDED POLYSTYRENE INSULATION BOARD.
- PAREX USA REINFORCING MESH EMBEDDED IN PAREX USA BASECOAT.
- PAREX USA BASECOAT.
- PAREX USA PRIMER (OPTIONAL).
- PAREX USA FINISH.
- PAREX USA MESH BACKWRAP.
- ELECTRICAL FIXTURE HOUSING (BY OTHERS).
- PAREX USA BASECOAT.
- SET ELECTRICAL FIXTURE IN ELASTOMERIC SEALANT (BY OTHERS).
- ELECTRICAL FIXTURE (BY OTHERS).

### SWM P1.05 TERMINATION @ ELECTRICAL FIXTURE (BY OTHERS)

REV. DATE: 05/04/18

NOTES: 1. To ensure a continuous air barrier across the building envelope, a continuous air seal should be made at each substrate change, joints/gaps, penetrations and dissimilar material terminations. These must be a consideration of the designer in the overall wall assembly design.

**Disclaimer:** The design specifications and construction shall comply with all local building codes and standards. Parex USA installation guidelines are for general information and guidance only and Parex USA specifically disclaims any liability for the use of this design and for design engineering or workmanship of any project. The assembly shall be designed to prevent condensation within the assembly. The designer and the user shall provide final drawings and specifications. Products shown other than those manufactured by Parex USA are shown for clarity of the Parex USA product only. Contact the manufacturer of such other products for installation instructions.

## WATERMASTER CI

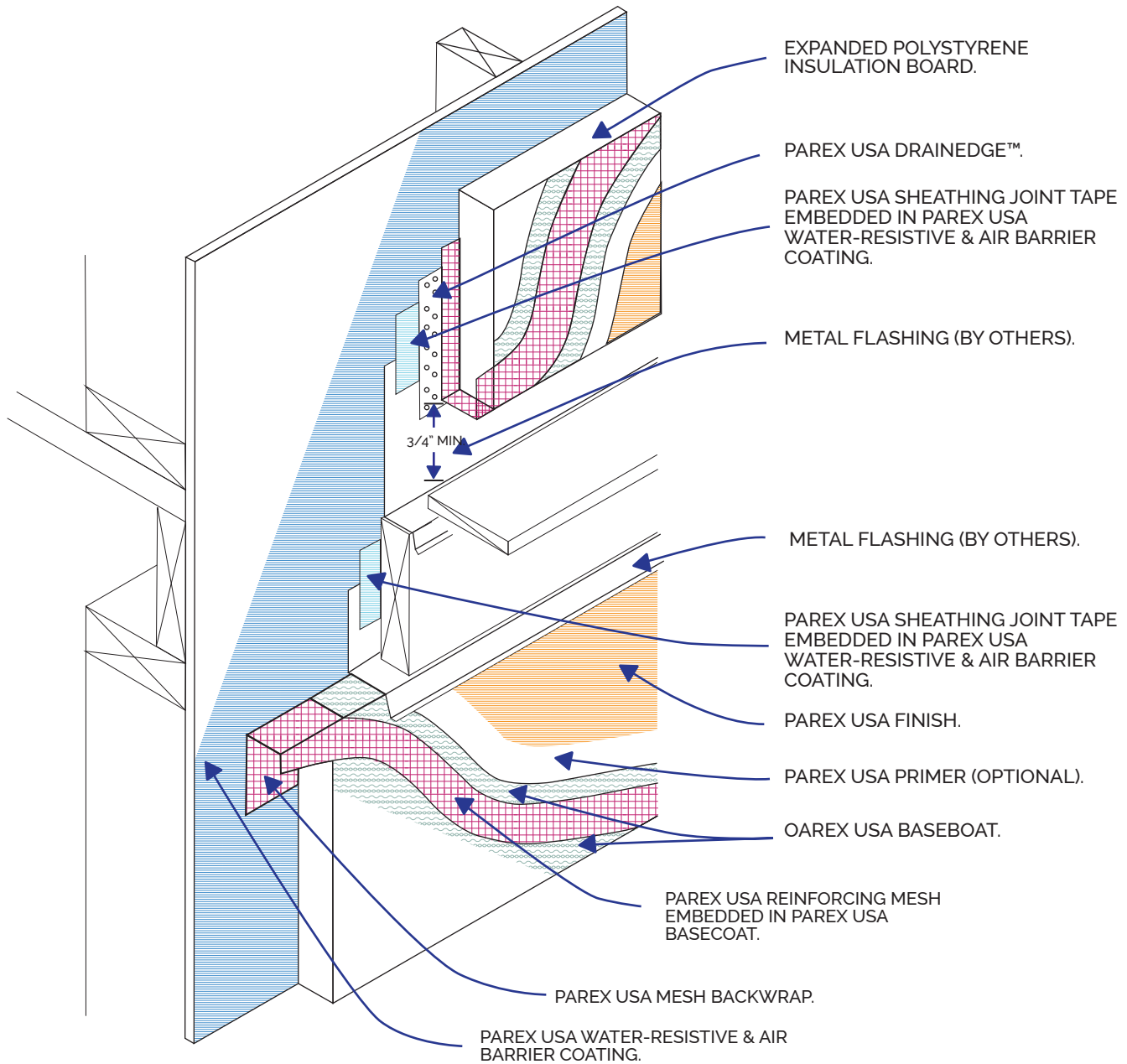

### SWM P1.06 DECK ATTACHMENT (BY OTHERS)

REV. DATE: 05/04/18

NOTES: 1. To ensure a continuous air barrier across the building envelope, a continuous air seal should be made at each substrate change, joints/gaps, penetrations and dissimilar material terminations. These must be a consideration of the designer in the overall wall assembly design.

**Disclaimer:** The design specifications and construction shall comply with all local building codes and standards. Parex USA installation guidelines are for general information and guidance only and Parex USA specifically disclaims any liability for the use of this design and for design engineering or workmanship of any project. The assembly shall be designed to prevent condensation within the assembly. The designer and the user shall provide final drawings and specifications. Products shown other than those manufactured by Parex USA are shown for clarity of the Parex USA product only. Contact the manufacturer of such other products for installation instructions.

## WATERMASTER CI

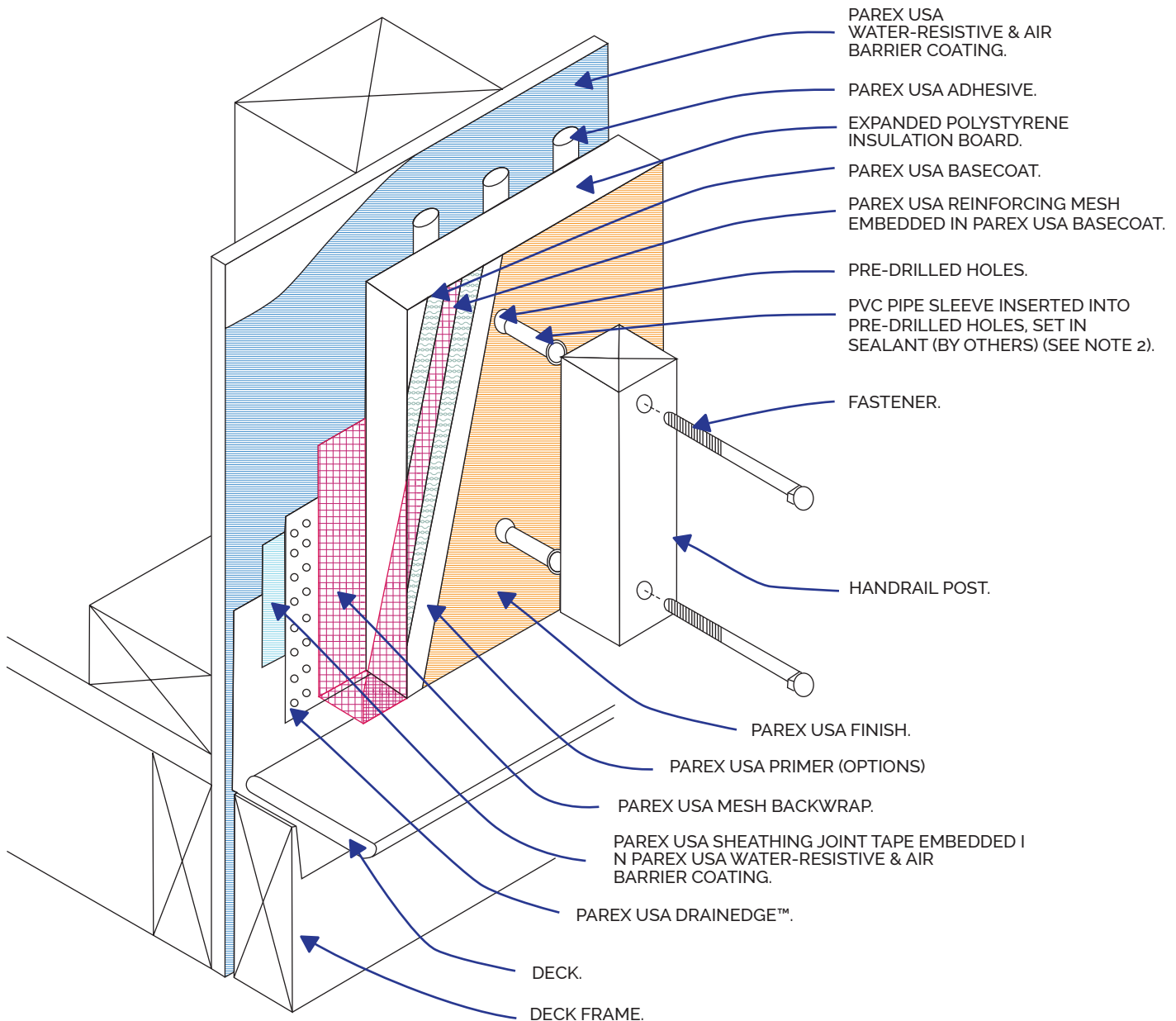

### SWM P1.07 HANDRAIL ATTACHMENT (BY OTHERS)

REV. DATE: 05/04/18

NOTES: 1. To ensure a continuous air barrier across the building envelope, a continuous air seal should be made at each substrate change, joints/gaps, penetrations and dissimilar material terminations. These must be a consideration of the designer in the overall wall assembly design.

**Disclaimer:** The design specifications and construction shall comply with all local building codes and standards. Parex USA installation guidelines are for general information and guidance only and Parex USA specifically disclaims any liability for the use of this design and for design engineering or workmanship of any project. The assembly shall be designed to prevent condensation within the assembly. The designer and the user shall provide final drawings and specifications. Products shown other than those manufactured by Parex USA are shown for clarity of the Parex USA product only. Contact the manufacturer of such other products for installation instructions.

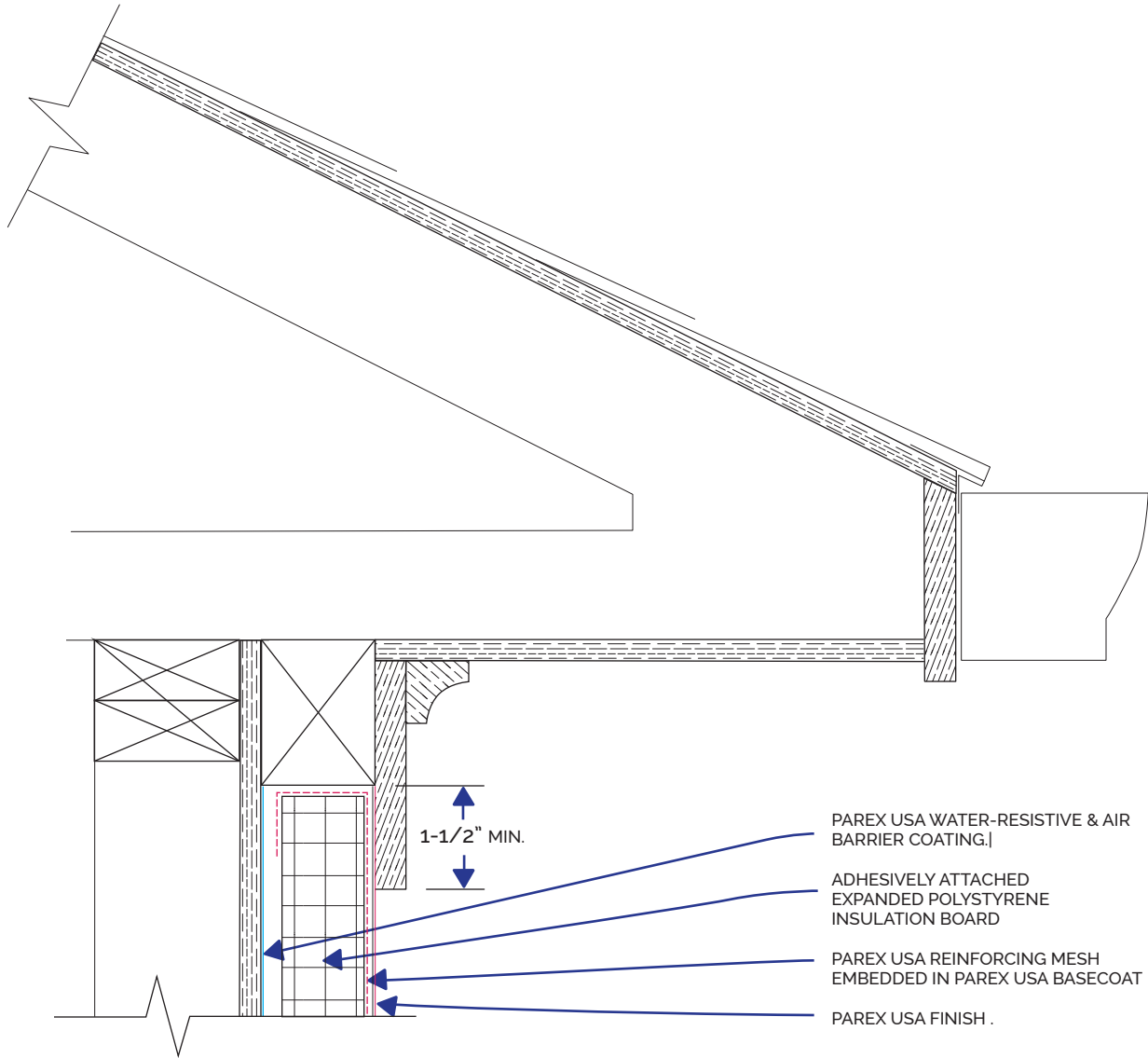

### SWM R1.01A TERMINATION AT BOX CORNICE (2D)

REV. DATE: 05/04/18

NOTES: 1. To ensure a continuous air barrier across the building envelope, a continuous air seal should be made at each substrate change, joints/gaps, penetrations and dissimilar material terminations. These must be a consideration of the designer in the overall wall assembly design.

**Disclaimer:** The design specifications and construction shall comply with all local building codes and standards. Parex USA installation guidelines are for general information and guidance only and Parex USA specifically disclaims any liability for the use of this design and for design engineering or workmanship of any project. The assembly shall be designed to prevent condensation within the assembly. The designer and the user shall provide final drawings and specifications. Products shown other than those manufactured by Parex USA are shown for clarity of the Parex USA product only. Contact the manufacturer of such other products for installation instructions.



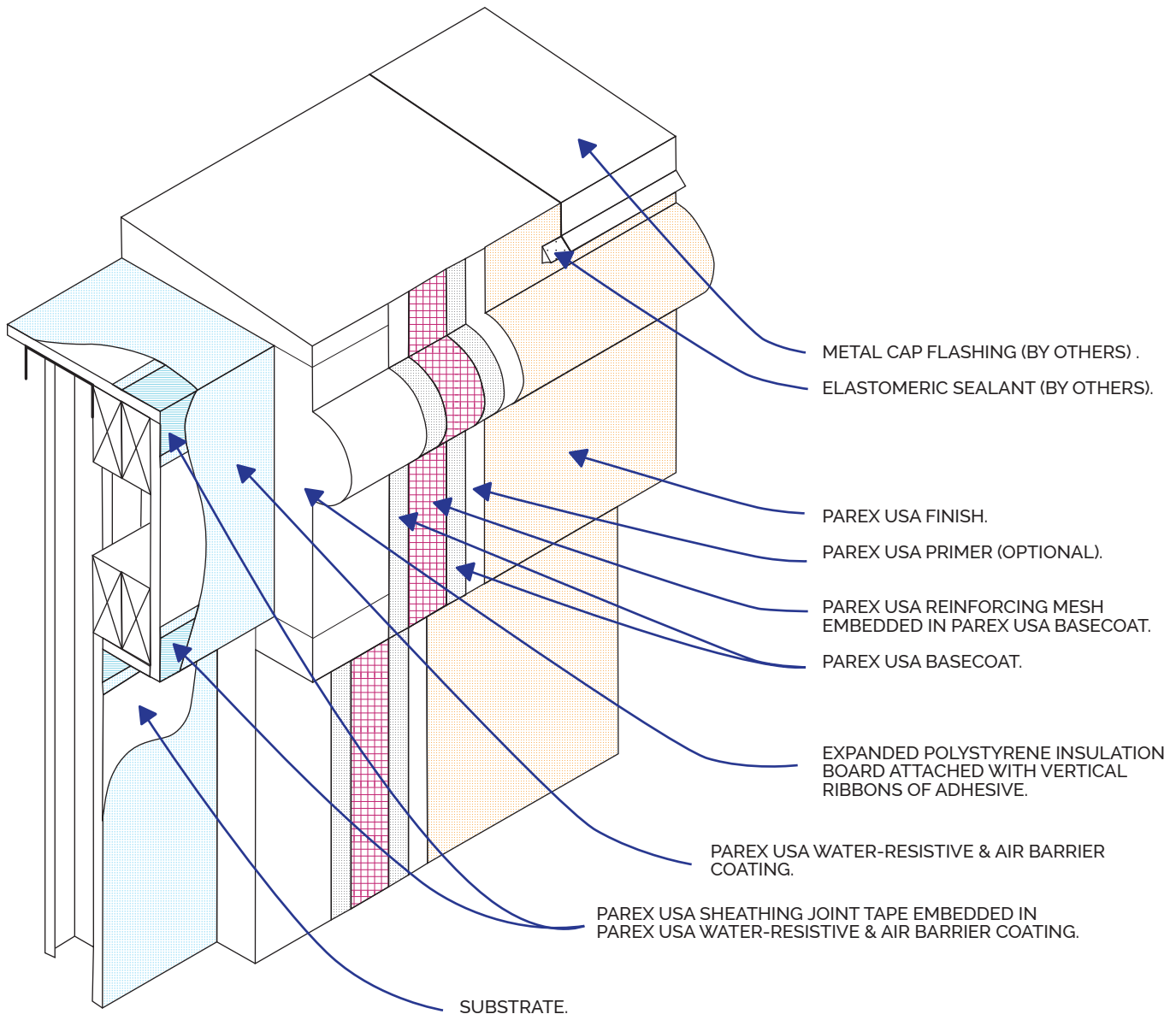

### SWM R1.01B TERMINATION AT CORNICE (ISO)

REV. DATE: 05/04/18

NOTES: 1. To ensure a continuous air barrier across the building envelope, a continuous air seal should be made at each substrate change, joints/gaps, penetrations and dissimilar material terminations. These must be a consideration of the designer in the overall wall assembly design.

**Disclaimer:** The design specifications and construction shall comply with all local building codes and standards. Parex USA installation guidelines are for general information and guidance only and Parex USA specifically disclaims any liability for the use of this design and for design engineering or workmanship of any project. The assembly shall be designed to prevent condensation within the assembly. The designer and the user shall provide final drawings and specifications. Products shown other than those manufactured by Parex USA are shown for clarity of the Parex USA product only. Contact the manufacturer of such other products for installation instructions.

## WATERMASTER CI

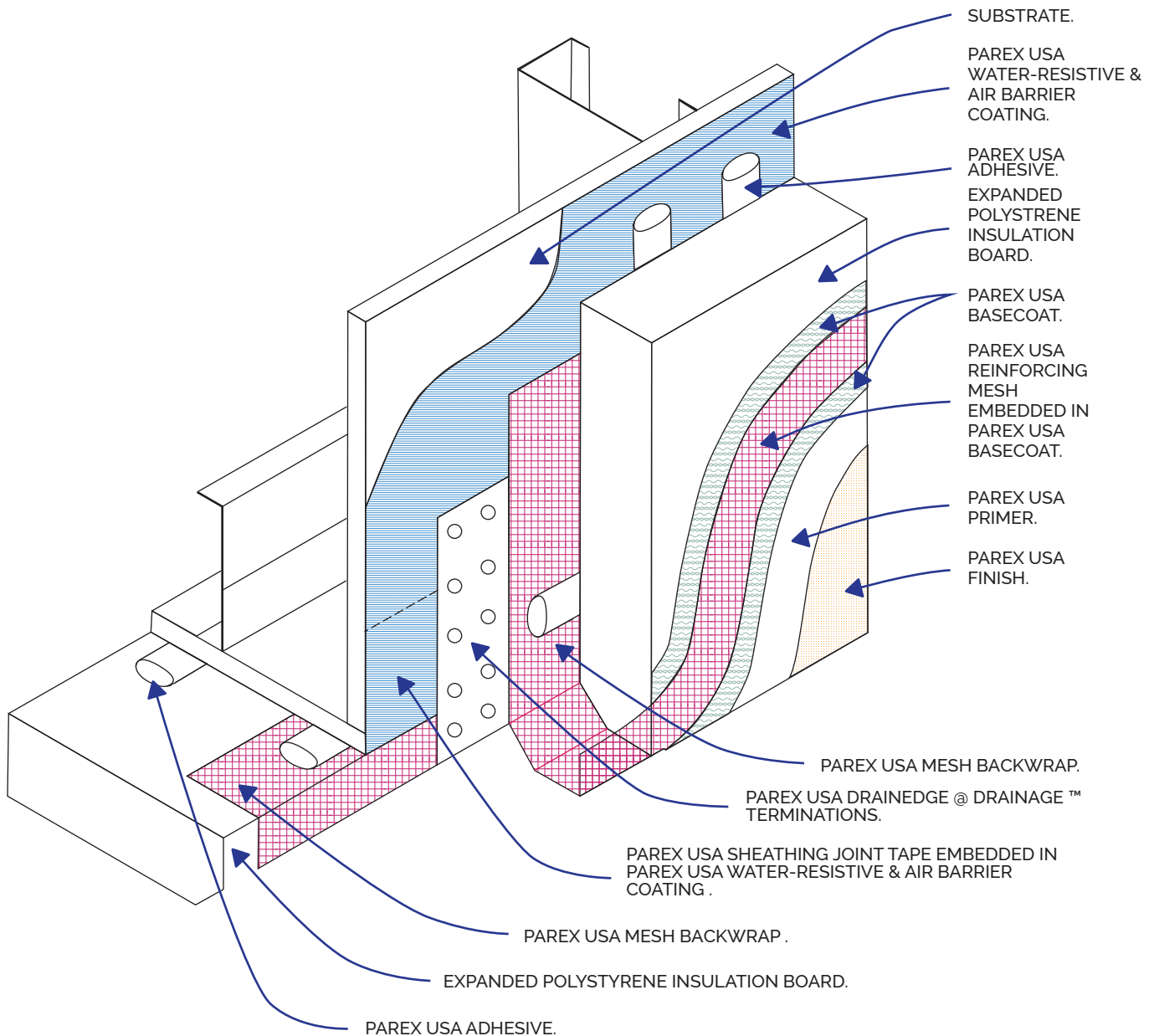

### SWM R1.02A SECTION AT FASCIA/SOFFIT WITH INSULATION

REV. DATE: 05/04/18

NOTES: 1. To ensure a continuous air barrier across the building envelope, a continuous air seal should be made at each substrate change, joints/gaps, penetrations and dissimilar material terminations. These must be a consideration of the designer in the overall wall assembly design.

**Disclaimer:** The design specifications and construction shall comply with all local building codes and standards. Parex USA installation guidelines are for general information and guidance only and Parex USA specifically disclaims any liability for the use of this design and for design engineering or workmanship of any project. The assembly shall be designed to prevent condensation within the assembly. The designer and the user shall provide final drawings and specifications. Products shown other than those manufactured by Parex USA are shown for clarity of the Parex USA product only. Contact the manufacturer of such other products for installation instructions.

## WATERMASTER CI

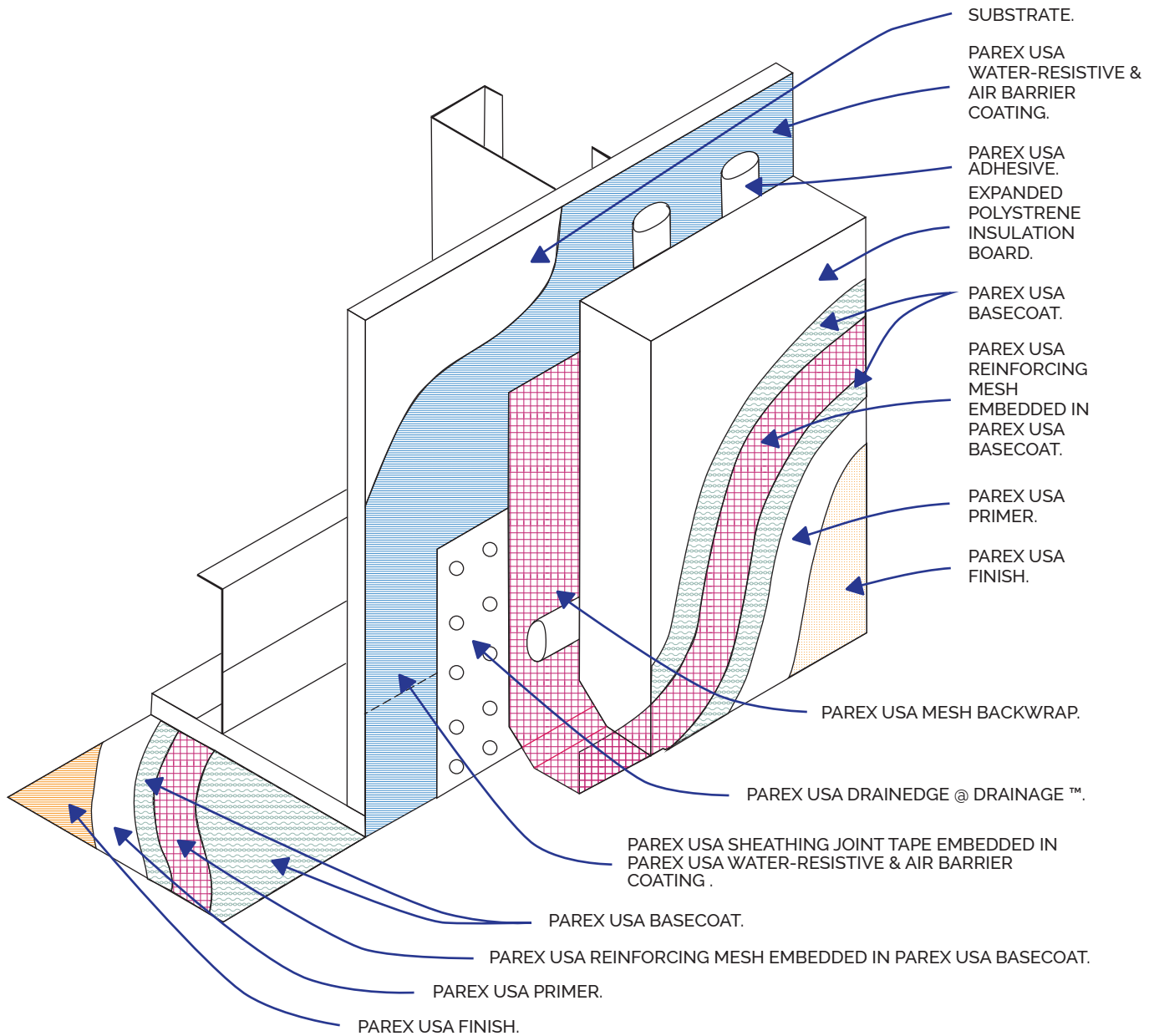

### SWM R1.02B SECTION AT FASCIA/SOFFIT WITHOUT INSULATION

REV. DATE: 05/04/18

NOTES: 1. To ensure a continuous air barrier across the building envelope, a continuous air seal should be made at each substrate change, joints/gaps, penetrations and dissimilar material terminations. These must be a consideration of the designer in the overall wall assembly design.

**Disclaimer:** The design specifications and construction shall comply with all local building codes and standards. Parex USA installation guidelines are for general information and guidance only and Parex USA specifically disclaims any liability for the use of this design and for design engineering or workmanship of any project. The assembly shall be designed to prevent condensation within the assembly. The designer and the user shall provide final drawings and specifications. Products shown other than those manufactured by Parex USA are shown for clarity of the Parex USA product only. Contact the manufacturer of such other products for installation instructions.

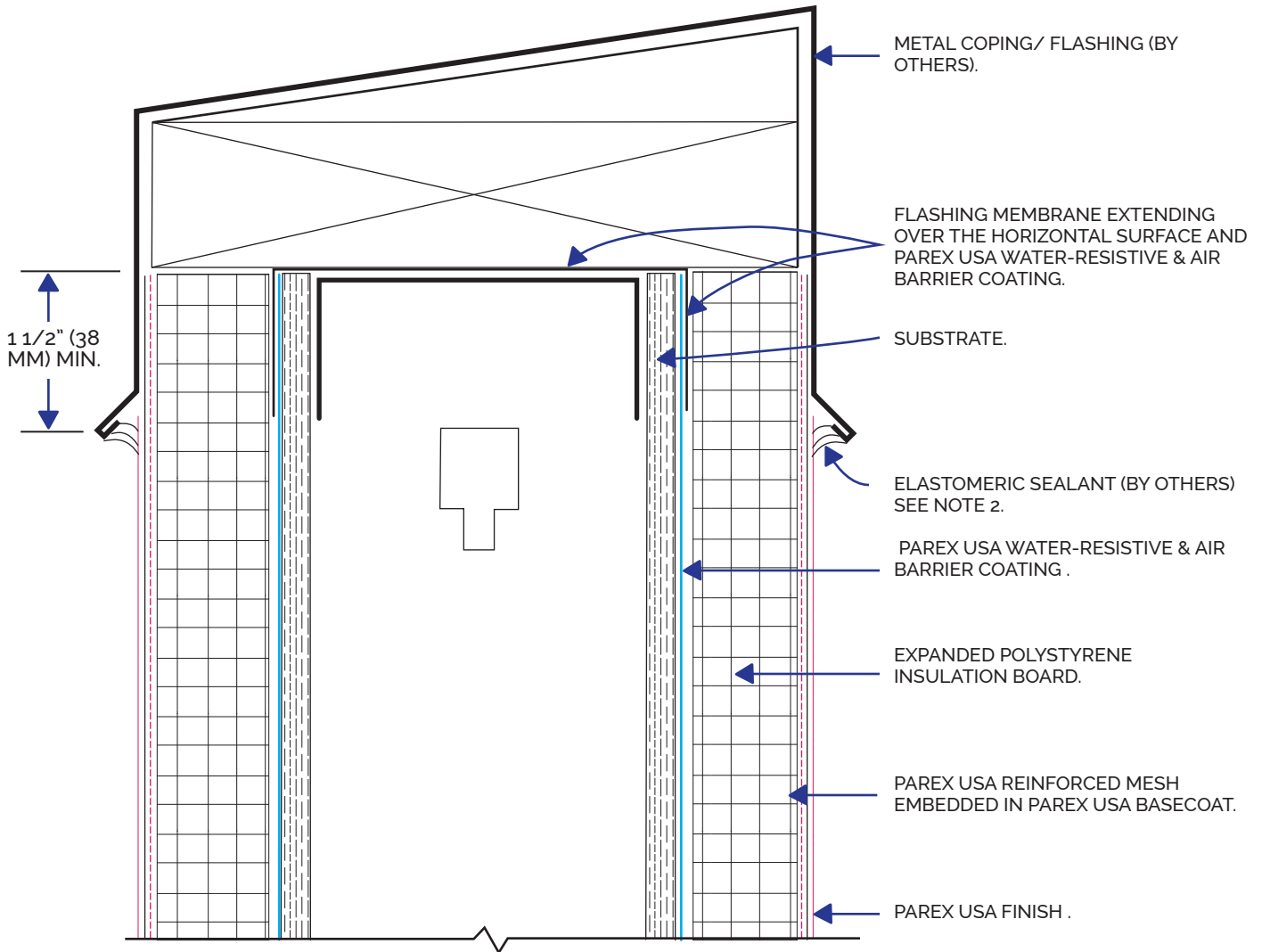

### SWM R1.03 PARAPET WALL TERMINATION AT CAP FLASHING

REV. DATE: 05/04/18

- NOTES: 1. To ensure a continuous air barrier across the building envelope, a continuous air seal should be made at each substrate change, joints/gaps, penetrations and dissimilar material terminations. These must be a consideration of the designer in the overall wall assembly design.
2. Some coping systems have an inner membrane that drains behind the metal flashing. Do not block drainage of these membranes with sealant.

**Disclaimer:** The design specifications and construction shall comply with all local building codes and standards. Parex USA installation guidelines are for general information and guidance only and Parex USA specifically disclaims any liability for the use of this design and for design engineering or workmanship of any project. The assembly shall be designed to prevent condensation within the assembly. The designer and the user shall provide final drawings and specifications. Products shown other than those manufactured by Parex USA are shown for clarity of the Parex USA product only. Contact the manufacturer of such other products for installation instructions.

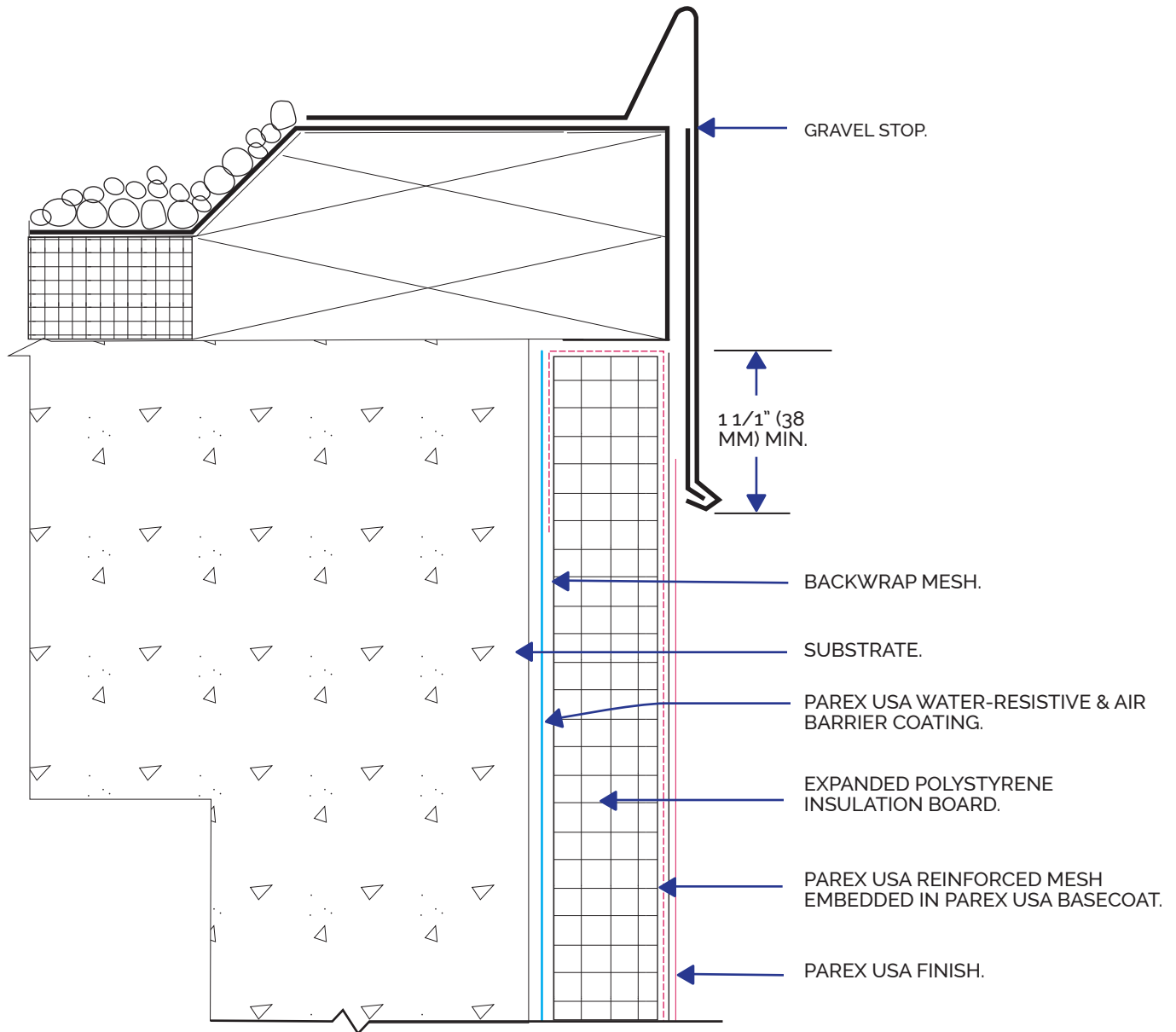

### SWM R1.04 TERMINATION AT GRAVEL STOP

REV. DATE: 05/04/18

NOTES: 1. To ensure a continuous air barrier across the building envelope, a continuous air seal should be made at each substrate change, joints/gaps, penetrations and dissimilar material terminations. These must be a consideration of the designer in the overall wall assembly design.

**Disclaimer:** The design specifications and construction shall comply with all local building codes and standards. Parex USA installation guidelines are for general information and guidance only and Parex USA specifically disclaims any liability for the use of this design and for design engineering or workmanship of any project. The assembly shall be designed to prevent condensation within the assembly. The designer and the user shall provide final drawings and specifications. Products shown other than those manufactured by Parex USA are shown for clarity of the Parex USA product only. Contact the manufacturer of such other products for installation instructions.

## WATERMASTER CI

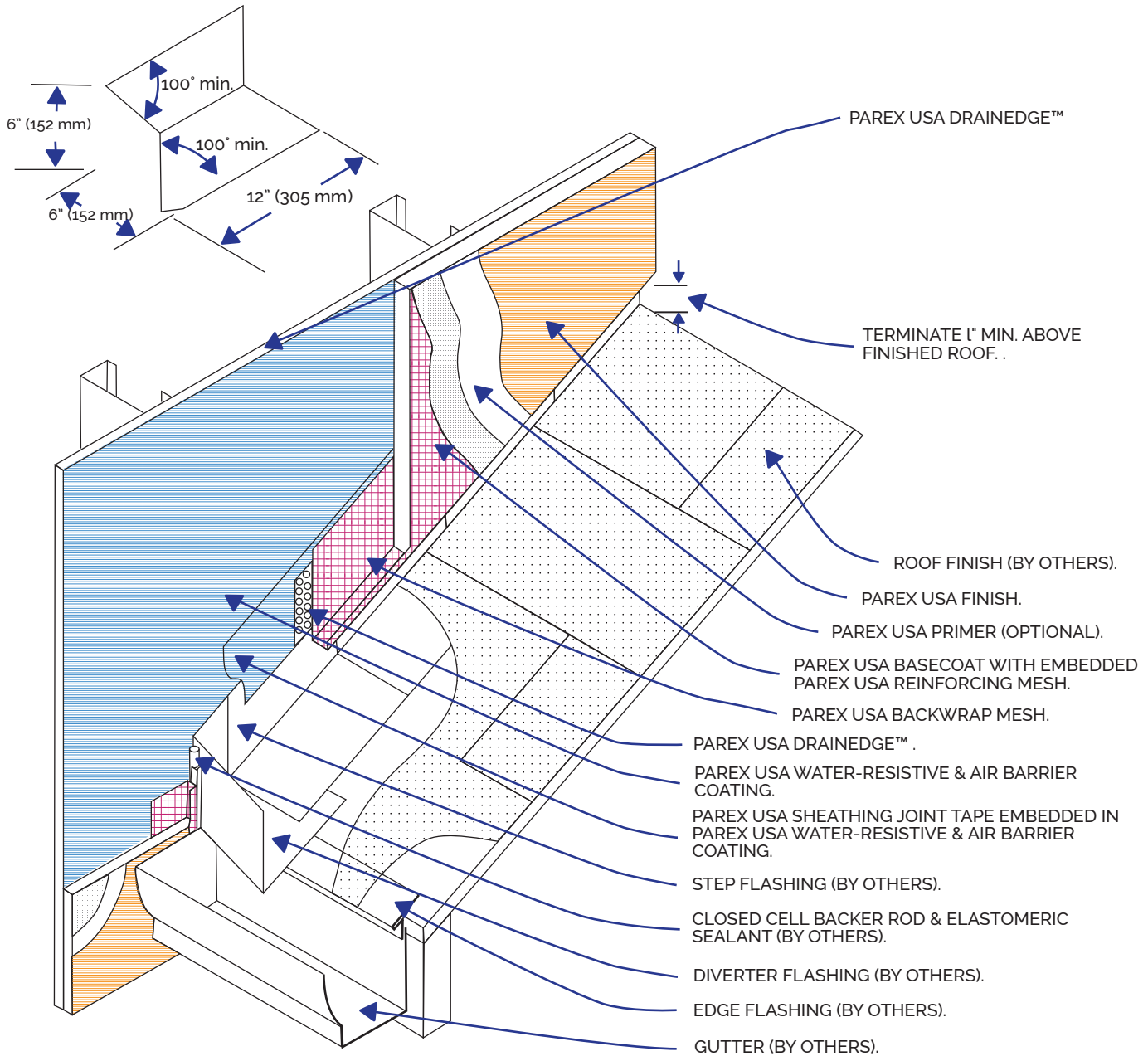

### SWM R1.05 INTERSECTION OF ROOF CORNICE AT SYSTEM

REV. DATE: 05/04/18

NOTES: 1. To ensure a continuous air barrier across the building envelope, a continuous air seal should be made at each substrate change, joints/gaps, penetrations and dissimilar material terminations. These must be a consideration of the designer in the overall wall assembly design.

**Disclaimer:** The design specifications and construction shall comply with all local building codes and standards. Parex USA installation guidelines are for general information and guidance only and Parex USA specifically disclaims any liability for the use of this design and for design engineering or workmanship of any project. The assembly shall be designed to prevent condensation within the assembly. The designer and the user shall provide final drawings and specifications. Products shown other than those manufactured by Parex USA are shown for clarity of the Parex USA product only. Contact the manufacturer of such other products for installation instructions.

## WATERMASTER CI

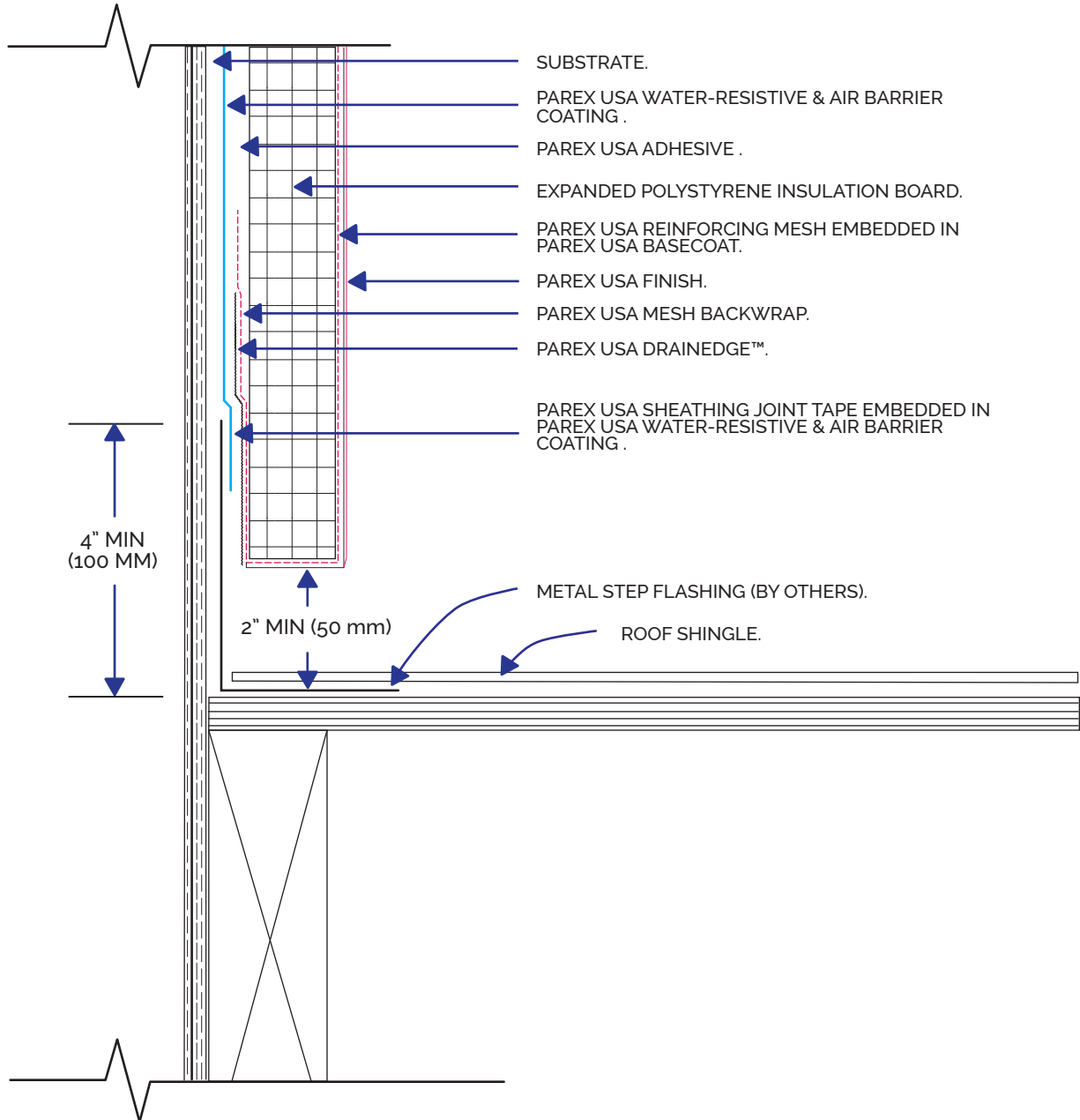

## SWM R1.06 TERMINATION AT ROOF

REV. DATE: 05/04/18

NOTES: 1. To ensure a continuous air barrier across the building envelope, a continuous air seal should be made at each substrate change, joints/gaps, penetrations and dissimilar material terminations. These must be a consideration of the designer in the overall wall assembly design.

**Disclaimer:** The design specifications and construction shall comply with all local building codes and standards. Parex USA installation guidelines are for general information and guidance only and Parex USA specifically disclaims any liability for the use of this design and for design engineering or workmanship of any project. The assembly shall be designed to prevent condensation within the assembly. The designer and the user shall provide final drawings and specifications. Products shown other than those manufactured by Parex USA are shown for clarity of the Parex USA product only. Contact the manufacturer of such other products for installation instructions.

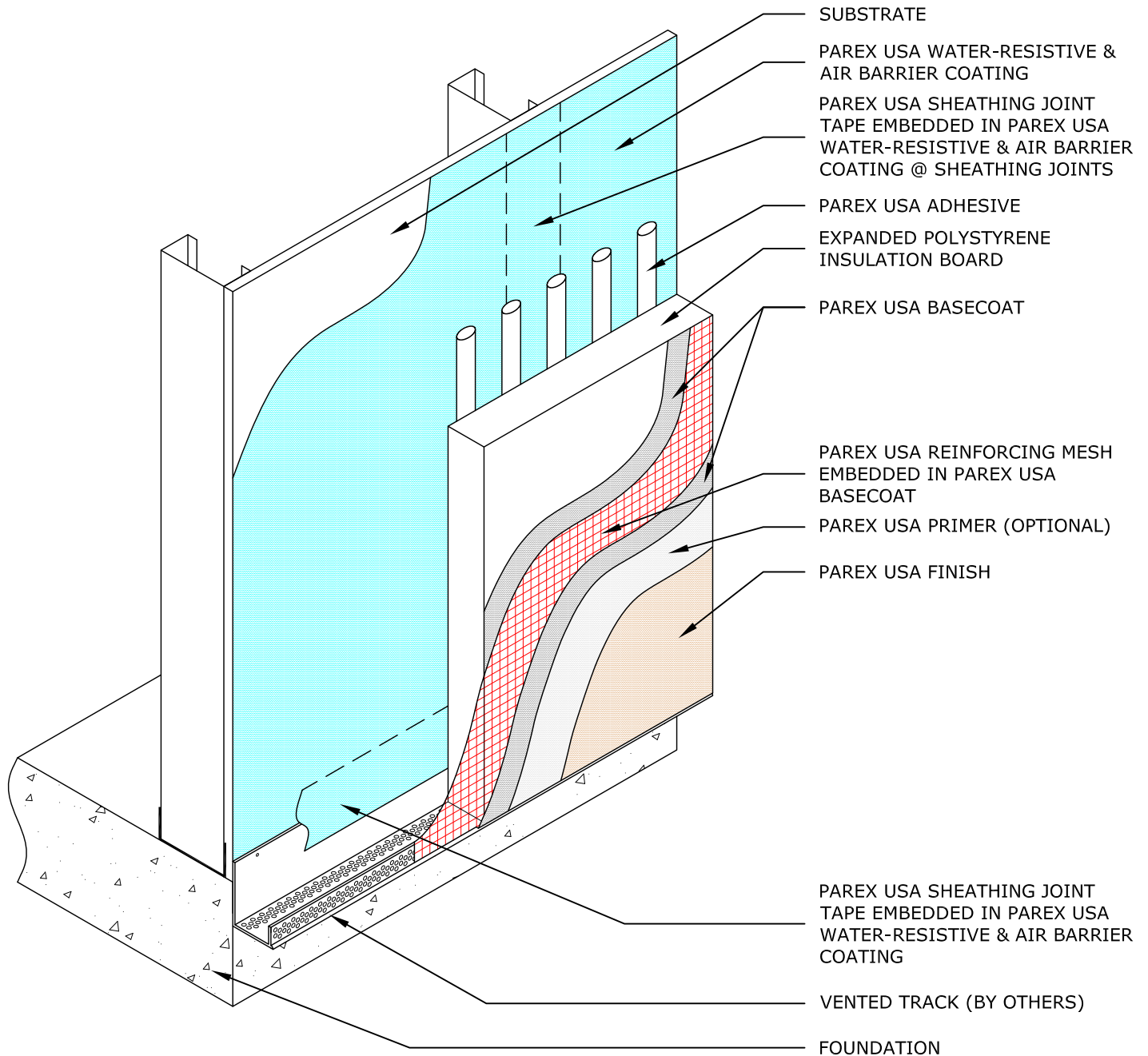

## SWM T1.01A TERMINATION AT FOUNDATION WITH VENTED TRACK

STANDARD WATERMASTER SYSTEM  
OPTIMUM WATERMASTER SYSTEM

**NOTE:** To ensure a continuous air barrier across the building envelope, a continuous air seal should be made at each substrate change, joints/gaps, penetrations and dissimilar material terminations. These must be a consideration of the designer in the overall wall assembly design.

**Disclaimer:** The design, specifications, and construction shall comply with all local building codes and standards. Parex USA installation guidelines are for general information and guidance only and Parex USA specifically disclaims any liability for the use of this design, and for design, engineering, or workmanship of any project. The assembly shall be designed to prevent condensation within the assembly. The designer and the user shall provide final drawings and specifications. Products shown other than those manufactured by Parex USA are shown for clarity of the Parex USA product only. Contact the manufacturer of such other products for installation instructions..



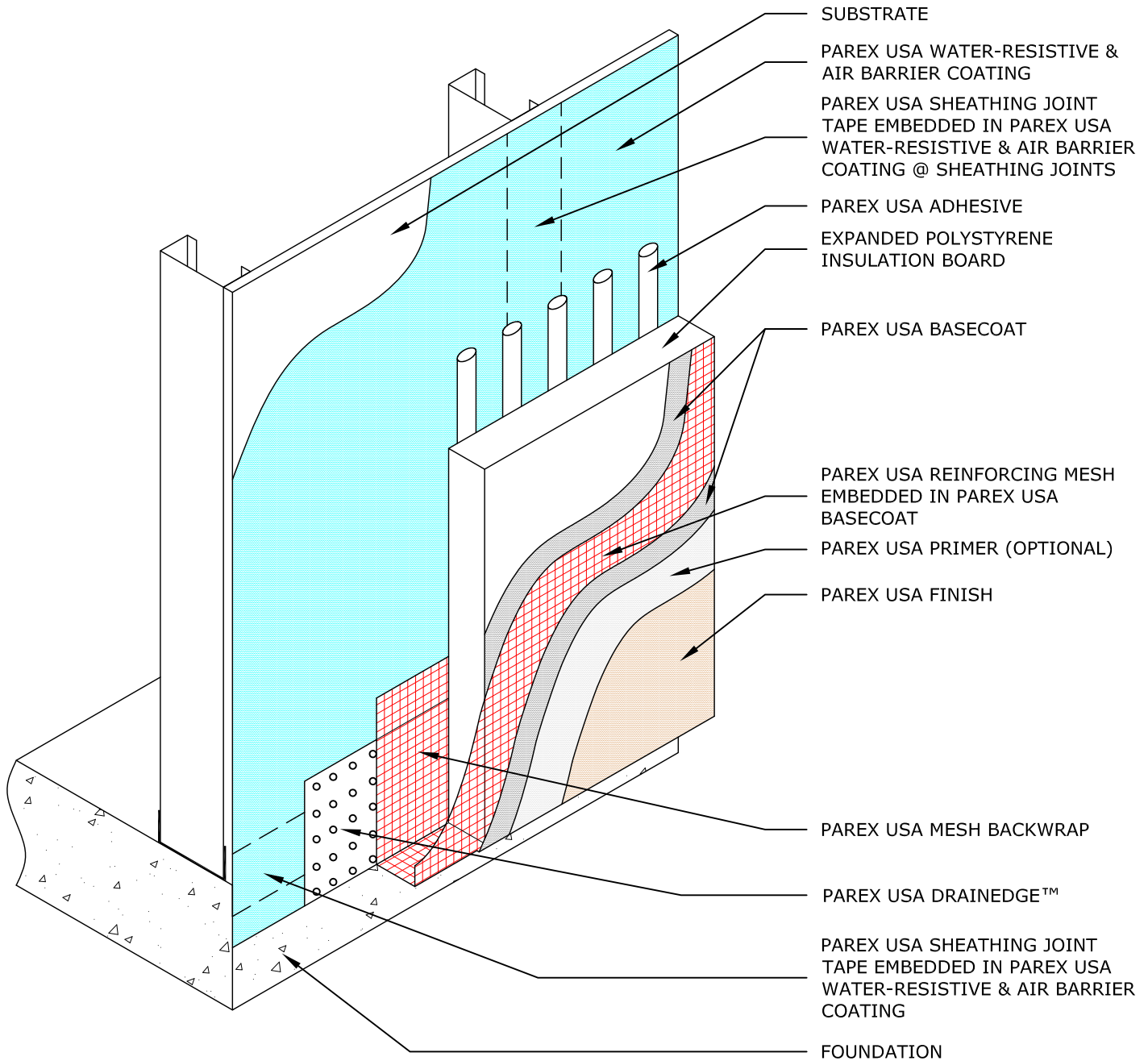

## SWM T1.01B TERMINATION AT FOUNDATION WITH BACKWRAPPING

STANDARD WATERMASTER SYSTEM  
OPTIMUM WATERMASTER SYSTEM

**NOTE:** To ensure a continuous air barrier across the building envelope, a continuous air seal should be made at each substrate change, joints/gaps, penetrations and dissimilar material terminations. These must be a consideration of the designer in the overall wall assembly design.

**Disclaimer:** The design, specifications, and construction shall comply with all local building codes and standards. Parex USA installation guidelines are for general information and guidance only and Parex USA specifically disclaims any liability for the use of this design, and for design, engineering, or workmanship of any project. The assembly shall be designed to prevent condensation within the assembly. The designer and the user shall provide final drawings and specifications. Products shown other than those manufactured by Parex USA are shown for clarity of the Parex USA product only. Contact the manufacturer of such other products for installation instructions.

## WATERMASTER CI

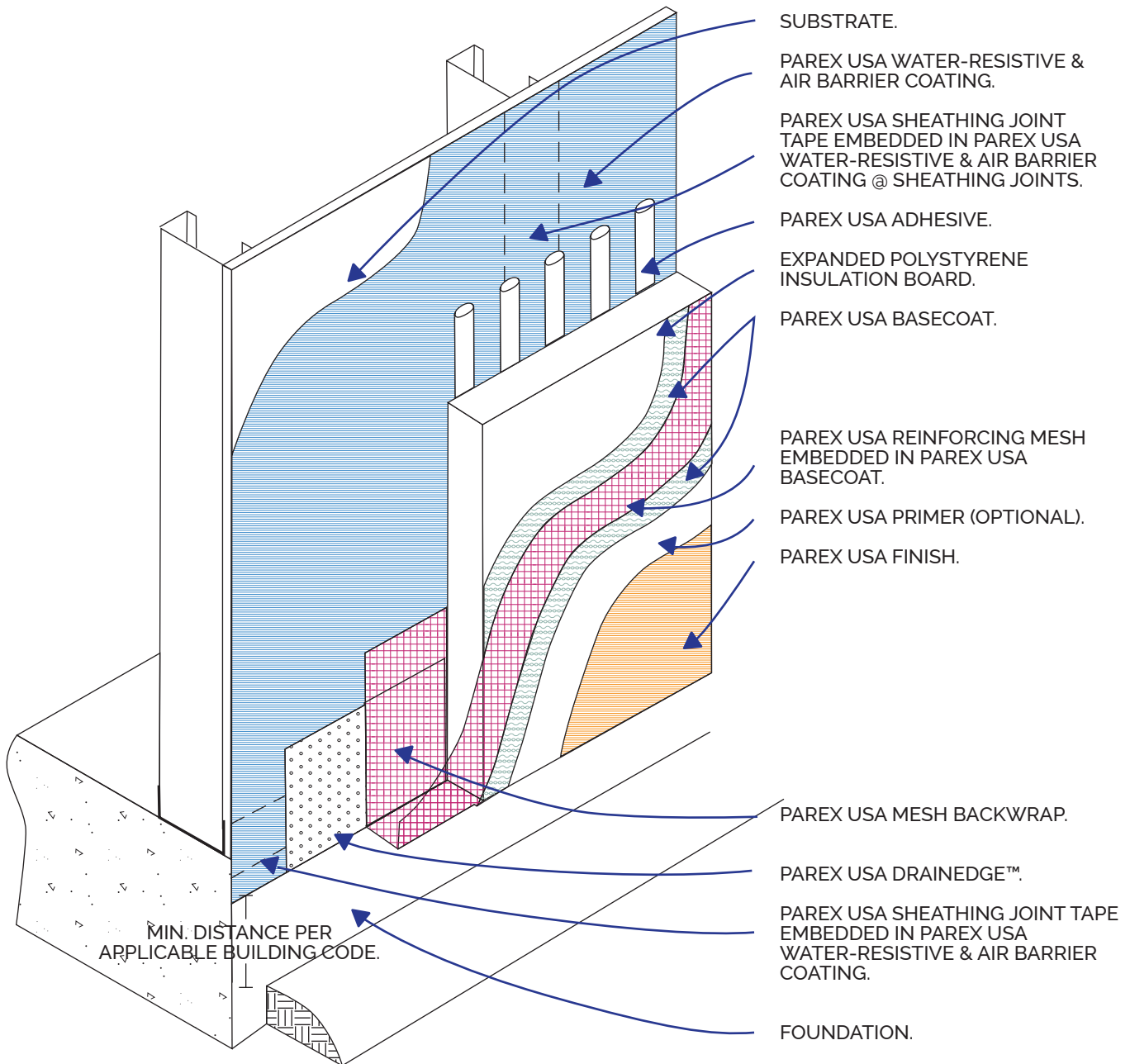

## SWM T1.02 TERMINATION AT GRADE

REV. DATE: 05/04/18

- NOTES: 1. To ensure a continuous air barrier across the building envelope, a continuous air seal should be made at each substrate change, joints/gaps, penetrations and dissimilar material terminations. These must be a consideration of the designer in the overall wall assembly design.
2. Sawn dimension lumber floor joists may require an expansion joint at the dissimilar substrate transition.

**Disclaimer:** The design specifications and construction shall comply with all local building codes and standards. Parex USA installation guidelines are for general information and guidance only and Parex USA specifically disclaims any liability for the use of this design and for design engineering or workmanship of any project. The assembly shall be designed to prevent condensation within the assembly. The designer and the user shall provide final drawings and specifications. Products shown other than those manufactured by Parex USA are shown for clarity of the Parex USA product only. Contact the manufacturer of such other products for installation instructions.

## WATERMASTER CI

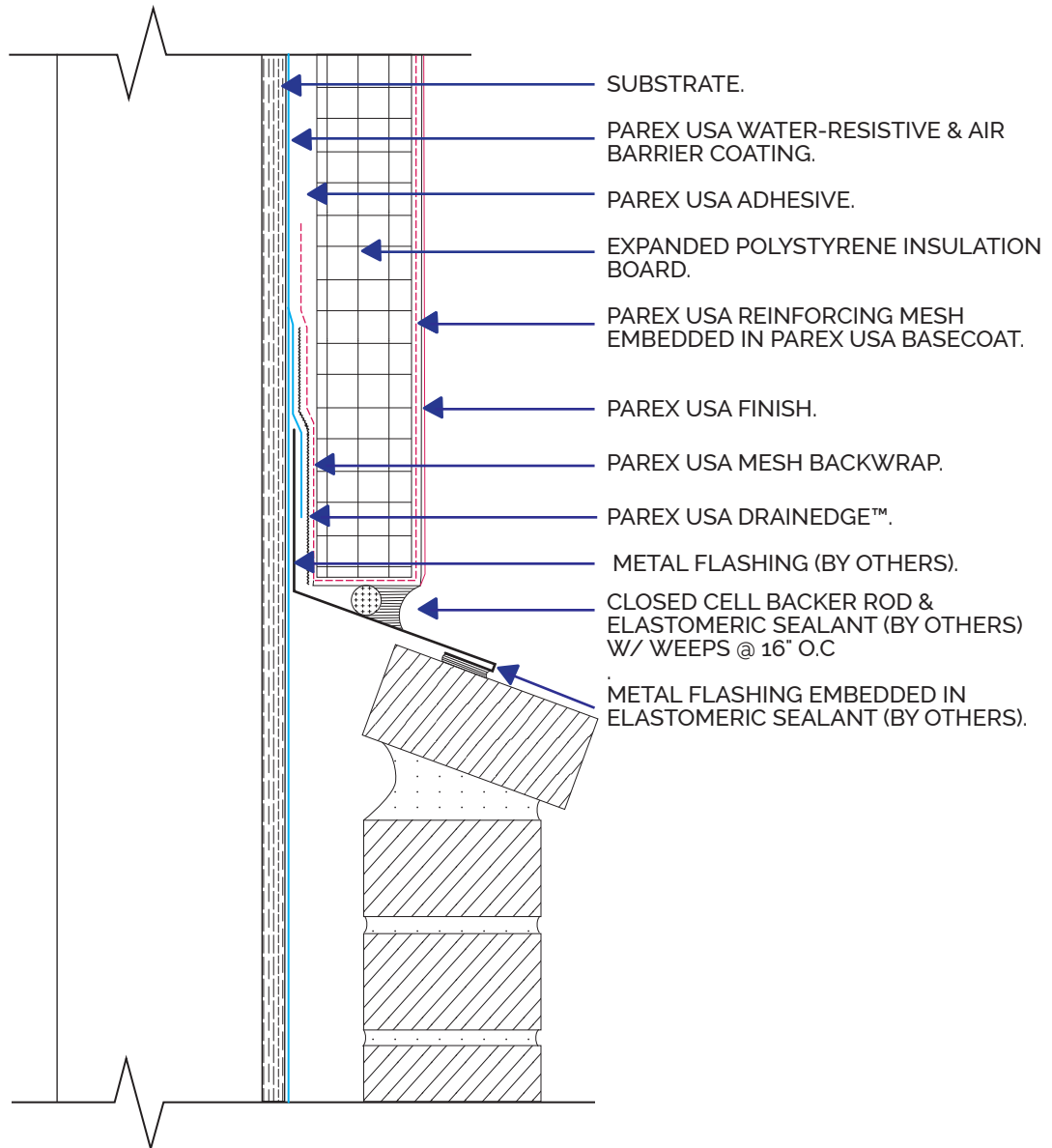

## SWM T1.03A CLADDING TRANSITION (2D)

REV. DATE: 05/04/18

NOTES: 1. To ensure a continuous air barrier across the building envelope, a continuous air seal should be made at each substrate change, joints/gaps, penetrations and dissimilar material terminations. These must be a consideration of the designer in the overall wall assembly design.

**Disclaimer:** The design specifications and construction shall comply with all local building codes and standards. Parex USA installation guidelines are for general information and guidance only and Parex USA specifically disclaims any liability for the use of this design and for design engineering or workmanship of any project. The assembly shall be designed to prevent condensation within the assembly. The designer and the user shall provide final drawings and specifications. Products shown other than those manufactured by Parex USA are shown for clarity of the Parex USA product only. Contact the manufacturer of such other products for installation instructions.

## WATERMASTER CI

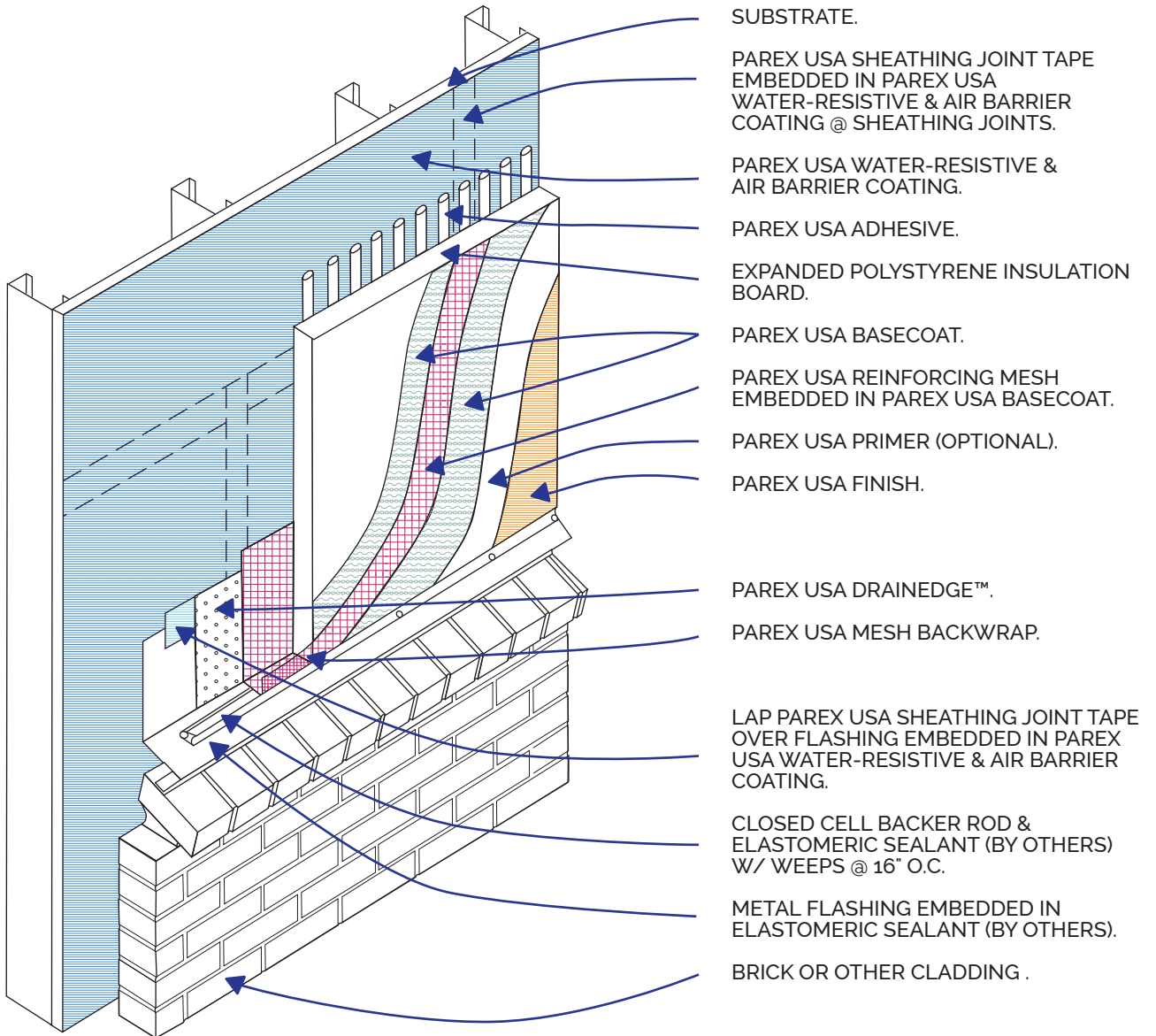

SUBSTRATE.

PAREX USA SHEATHING JOINT TAPE EMBEDDED IN PAREX USA WATER-RESISTIVE & AIR BARRIER COATING @ SHEATHING JOINTS.

PAREX USA WATER-RESISTIVE & AIR BARRIER COATING.

PAREX USA ADHESIVE.

EXPANDED POLYSTYRENE INSULATION BOARD.

PAREX USA BASECOAT.

PAREX USA REINFORCING MESH EMBEDDED IN PAREX USA BASECOAT.

PAREX USA PRIMER (OPTIONAL).

PAREX USA FINISH.

PAREX USA DRAINEDGE™.

PAREX USA MESH BACKWRAP.

LAP PAREX USA SHEATHING JOINT TAPE OVER FLASHING EMBEDDED IN PAREX USA WATER-RESISTIVE & AIR BARRIER COATING.

CLOSED CELL BACKER ROD & ELASTOMERIC SEALANT (BY OTHERS) W/ WEEPS @ 16" O.C.

METAL FLASHING EMBEDDED IN ELASTOMERIC SEALANT (BY OTHERS).

BRICK OR OTHER CLADDING .

## SWM T1.03B CLADDING TRANSITION (ISO)

REV. DATE: 05/04/18

NOTES: 1. To ensure a continuous air barrier across the building envelope, a continuous air seal should be made at each substrate change, joints/gaps, penetrations and dissimilar material terminations. These must be a consideration of the designer in the overall wall assembly design.

**Disclaimer:** The design specifications and construction shall comply with all local building codes and standards. Parex USA installation guidelines are for general information and guidance only and Parex USA specifically disclaims any liability for the use of this design and for design engineering or workmanship of any project. The assembly shall be designed to prevent condensation within the assembly. The designer and the user shall provide final drawings and specifications. Products shown other than those manufactured by Parex USA are shown for clarity of the Parex USA product only. Contact the manufacturer of such other products for installation instructions.

# PAREXUSA

## WATERMASTER CI

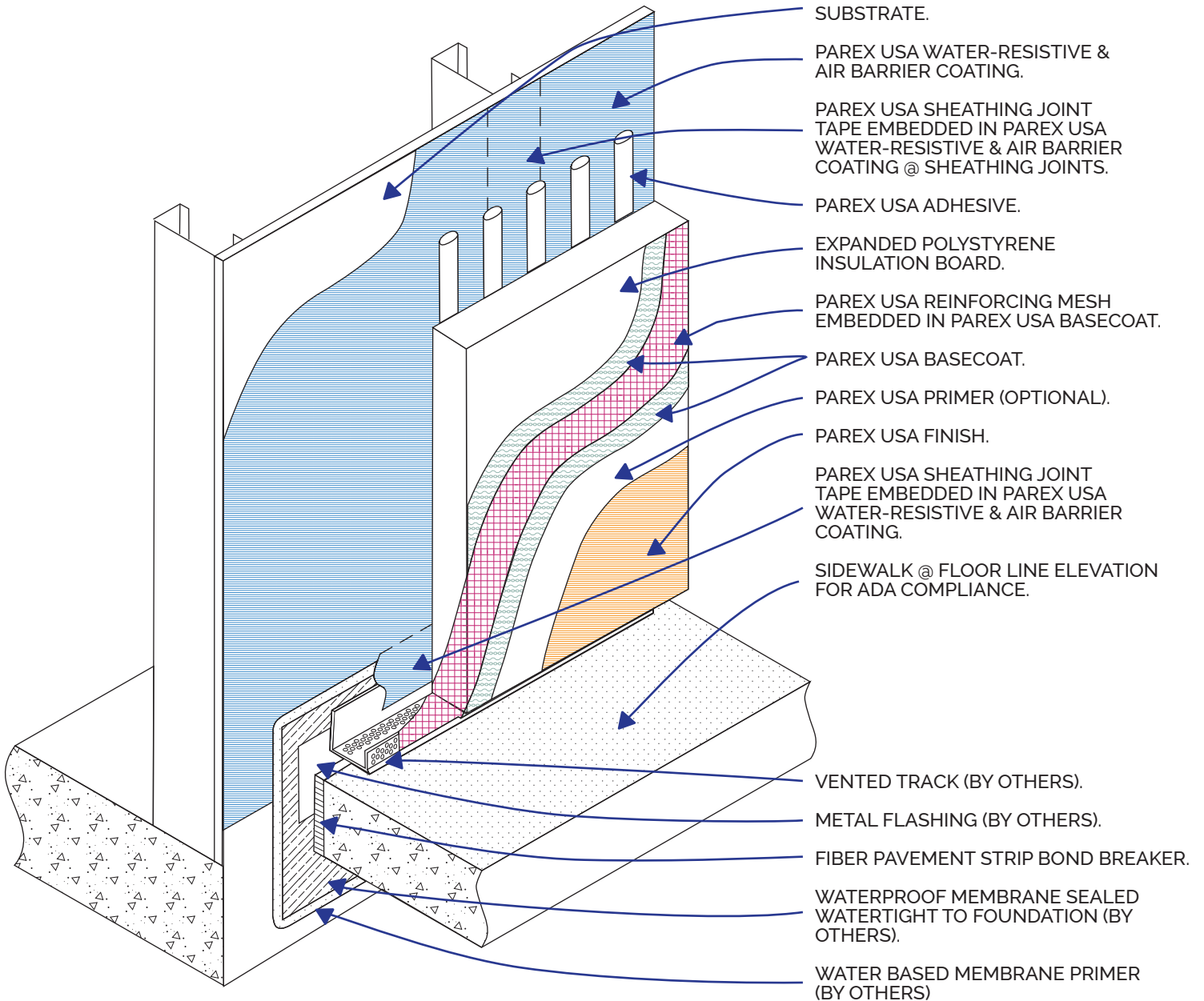

## SWM T1.04 TERMINATION AT ADA SIDEWALK

REV. DATE: 05/04/18

NOTES: 1. To ensure a continuous air barrier across the building envelope, a continuous air seal should be made at each substrate change, joints/gaps, penetrations and dissimilar material terminations. These must be a consideration of the designer in the overall wall assembly design.

**Disclaimer:** The design specifications and construction shall comply with all local building codes and standards. Parex USA installation guidelines are for general information and guidance only and Parex USA specifically disclaims any liability for the use of this design and for design engineering or workmanship of any project. The assembly shall be designed to prevent condensation within the assembly. The designer and the user shall provide final drawings and specifications. Products shown other than those manufactured by Parex USA are shown for clarity of the Parex USA product only. Contact the manufacturer of such other products for installation instructions.

## WATERMASTER CI

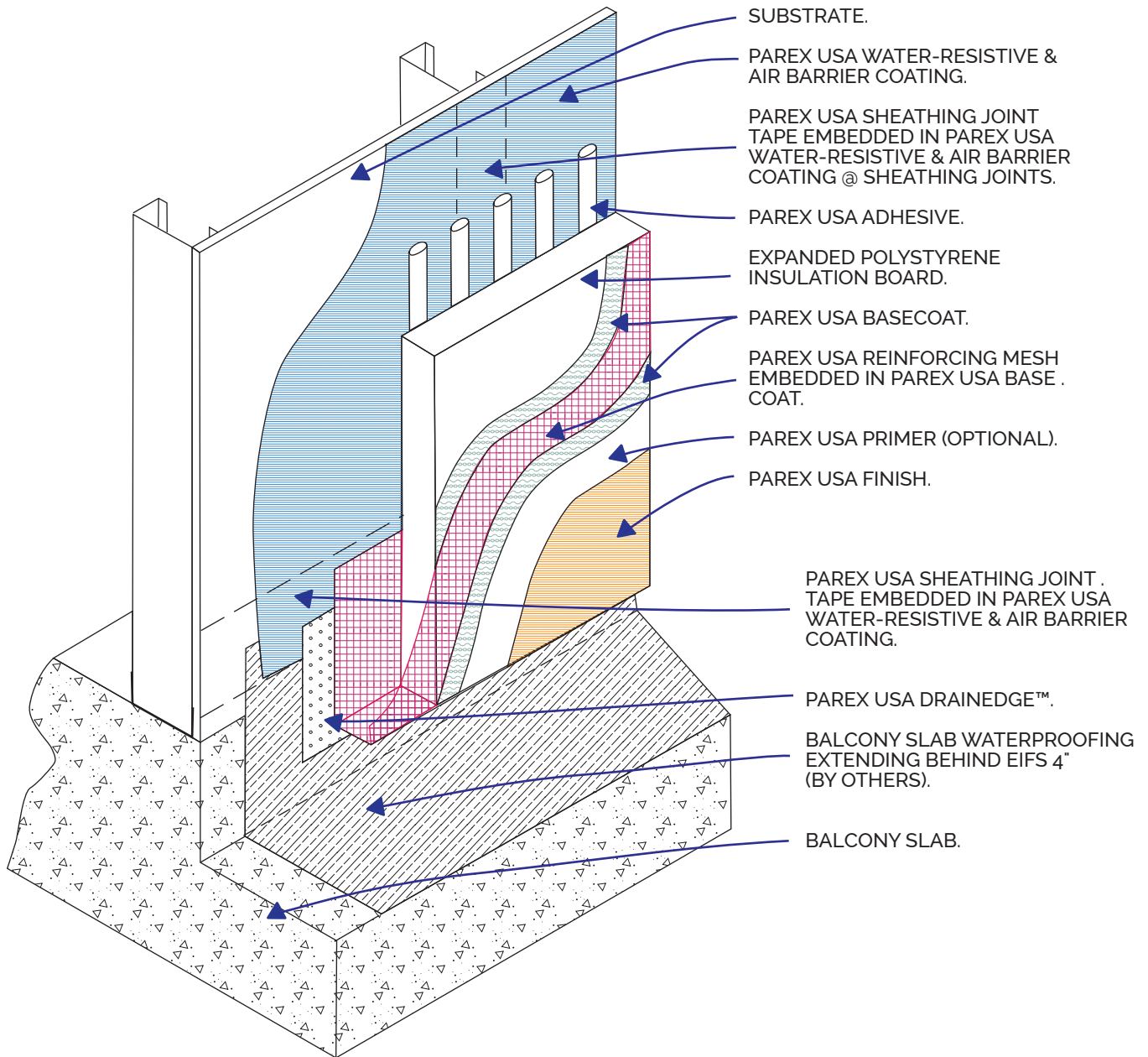

## SWM T1.05 TERMINATION AT BALCONY SLAB

REV. DATE: 05/04/18

NOTES: 1. To ensure a continuous air barrier across the building envelope, a continuous air seal should be made at each substrate change, joints/gaps, penetrations and dissimilar material terminations. These must be a consideration of the designer in the overall wall assembly design.

**Disclaimer:** The design specifications and construction shall comply with all local building codes and standards. Parex USA installation guidelines are for general information and guidance only and Parex USA specifically disclaims any liability for the use of this design and for design engineering or workmanship of any project. The assembly shall be designed to prevent condensation within the assembly. The designer and the user shall provide final drawings and specifications. Products shown other than those manufactured by Parex USA are shown for clarity of the Parex USA product only. Contact the manufacturer of such other products for installation instructions.

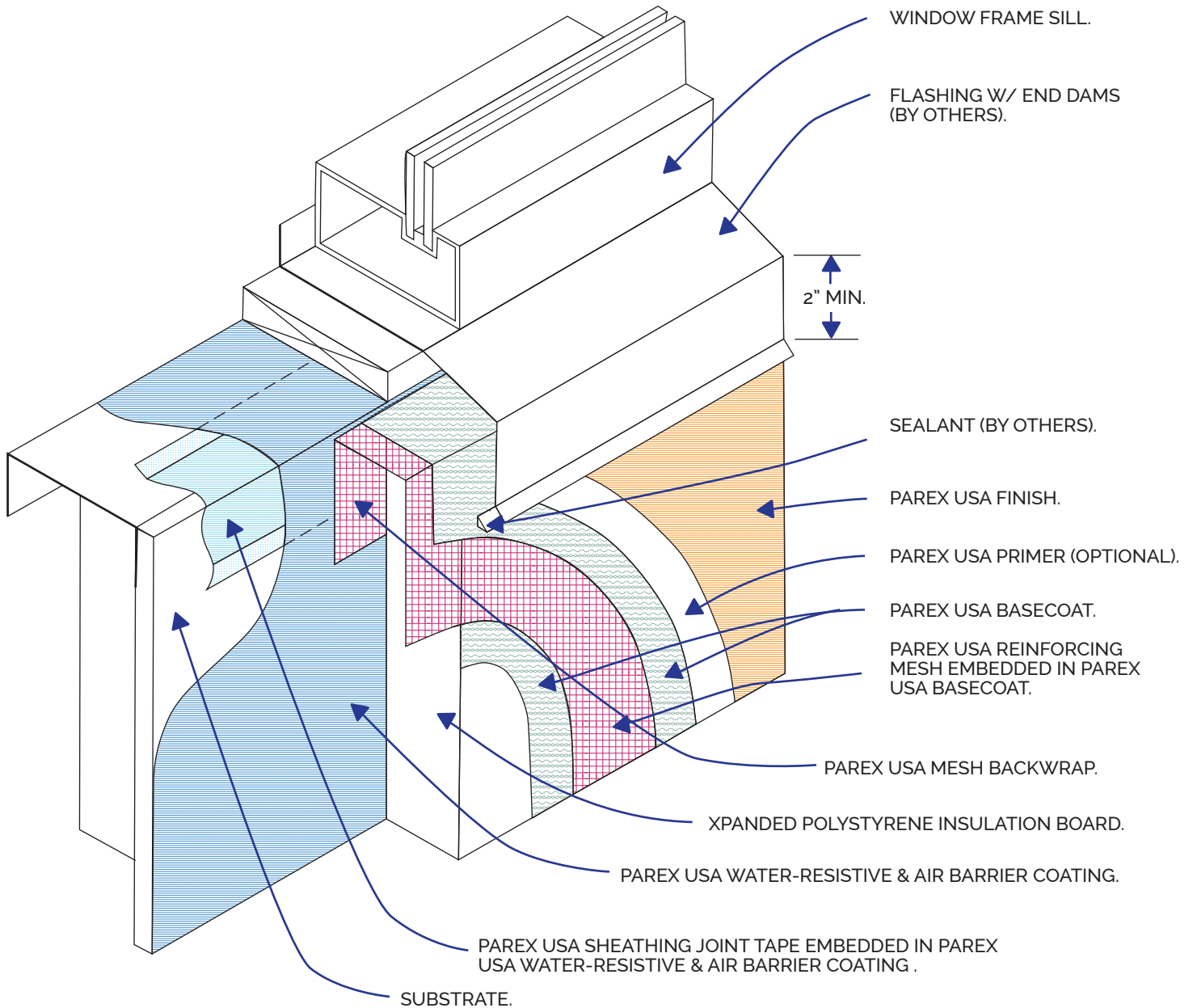

## SWM W1.03B TERMINATION AT METAL FLASHED WINDOW SILL

REV. DATE: 05/04/18

- NOTES: 1. To ensure a continuous air barrier across the building envelope, a continuous air seal should be made at each substrate change, joints/gaps, penetrations and dissimilar material terminations. These must be a consideration of the designer in the overall wall assembly design.
2. For more information, see Parex USA Water Resistive Barrier Details.

**Disclaimer:** The design specifications and construction shall comply with all local building codes and standards. Parex USA installation guidelines are for general information and guidance only and Parex USA specifically disclaims any liability for the use of this design and for design engineering or workmanship of any project. The assembly shall be designed to prevent condensation within the assembly. The designer and the user shall provide final drawings and specifications. Products shown other than those manufactured by Parex USA are shown for clarity of the Parex USA product only. Contact the manufacturer of such other products for installation instructions.

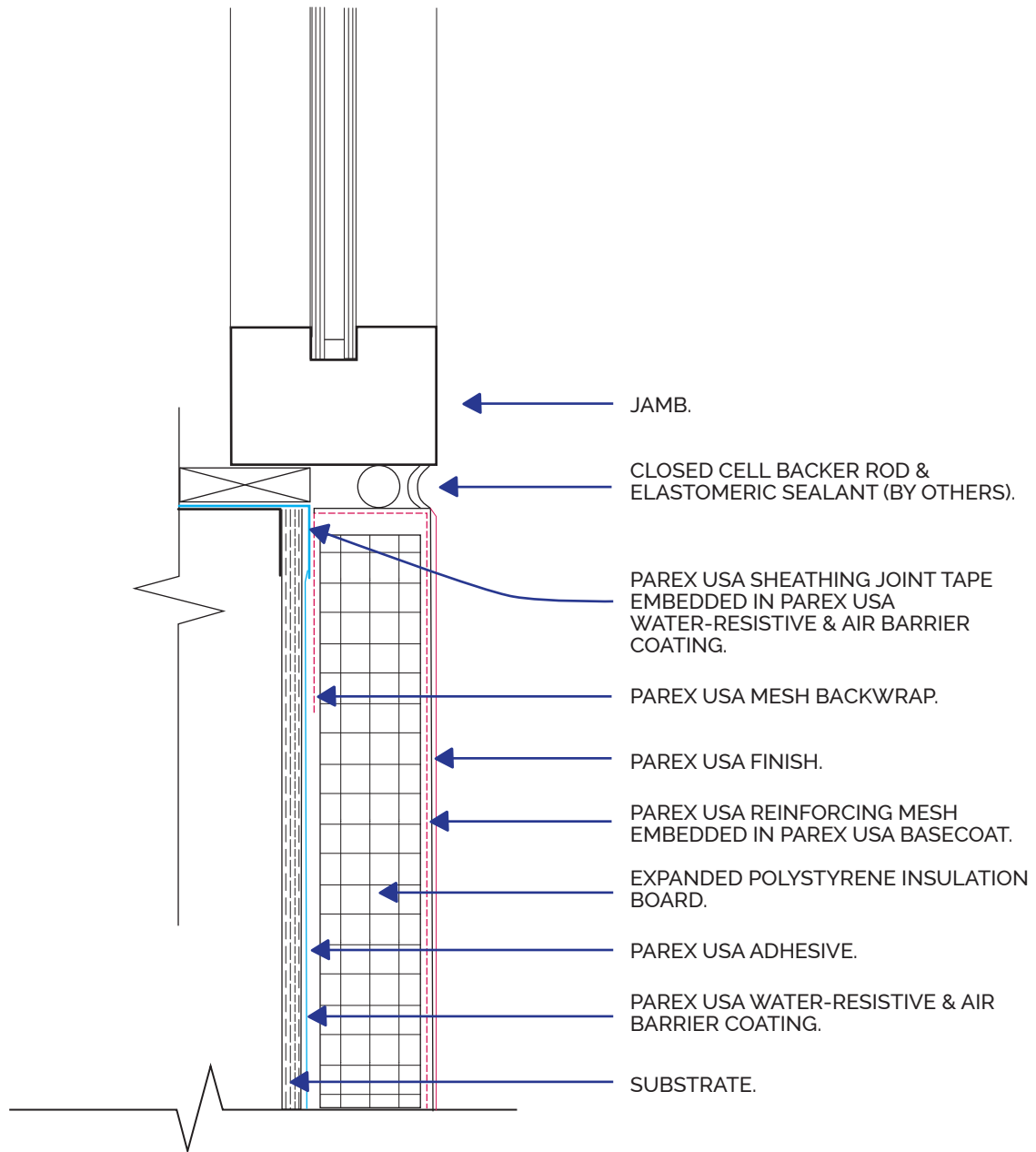

### SWM W1.04 TERMINATION AT WINDOW JAMB

REV. DATE: 05/04/18

NOTES: 1. To ensure a continuous air barrier across the building envelope, a continuous air seal should be made at each substrate change, joints/gaps, penetrations and dissimilar material terminations. These must be a consideration of the designer in the overall wall assembly design.

**Disclaimer:** The design specifications and construction shall comply with all local building codes and standards. Parex USA installation guidelines are for general information and guidance only and Parex USA specifically disclaims any liability for the use of this design and for design engineering or workmanship of any project. The assembly shall be designed to prevent condensation within the assembly. The designer and the user shall provide final drawings and specifications. Products shown other than those manufactured by Parex USA are shown for clarity of the Parex USA product only. Contact the manufacturer of such other products for installation instructions.



## WATERMASTER CI

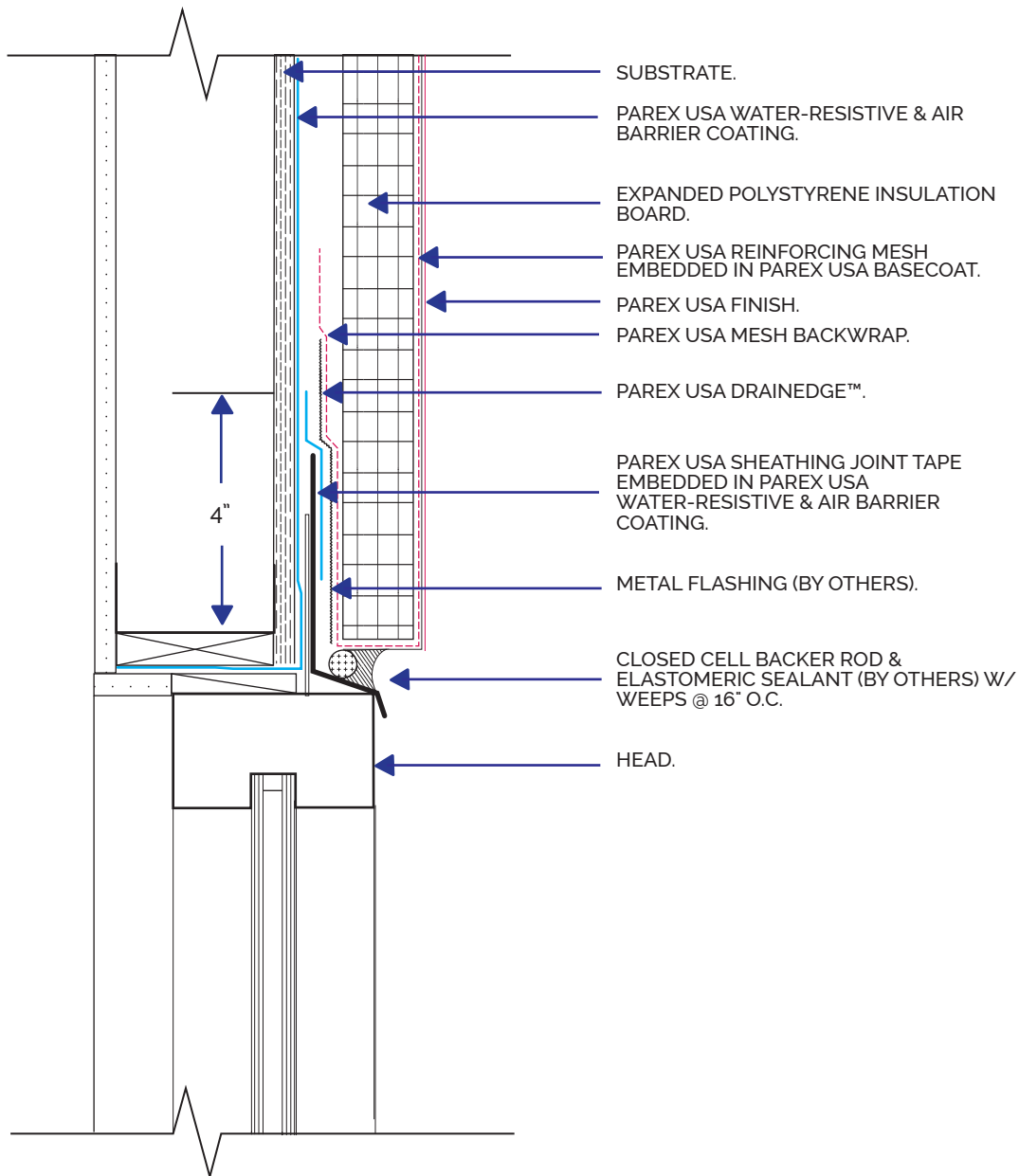

## SWM W1.05 TERMINATION WITH FINNED WINDOW HEAD

REV. DATE: 05/04/18

- NOTES: 1. To ensure a continuous air barrier across the building envelope, a continuous air seal should be made at each substrate change, joints/gaps, penetrations and dissimilar material terminations. These must be a consideration of the designer in the overall wall assembly design.
2. Do not use plastic track at window head.

**Disclaimer:** The design specifications and construction shall comply with all local building codes and standards. Parex USA installation guidelines are for general information and guidance only and Parex USA specifically disclaims any liability for the use of this design and for design engineering or workmanship of any project. The assembly shall be designed to prevent condensation within the assembly. The designer and the user shall provide final drawings and specifications. Products shown other than those manufactured by Parex USA are shown for clarity of the Parex USA product only. Contact the manufacturer of such other products for installation instructions.

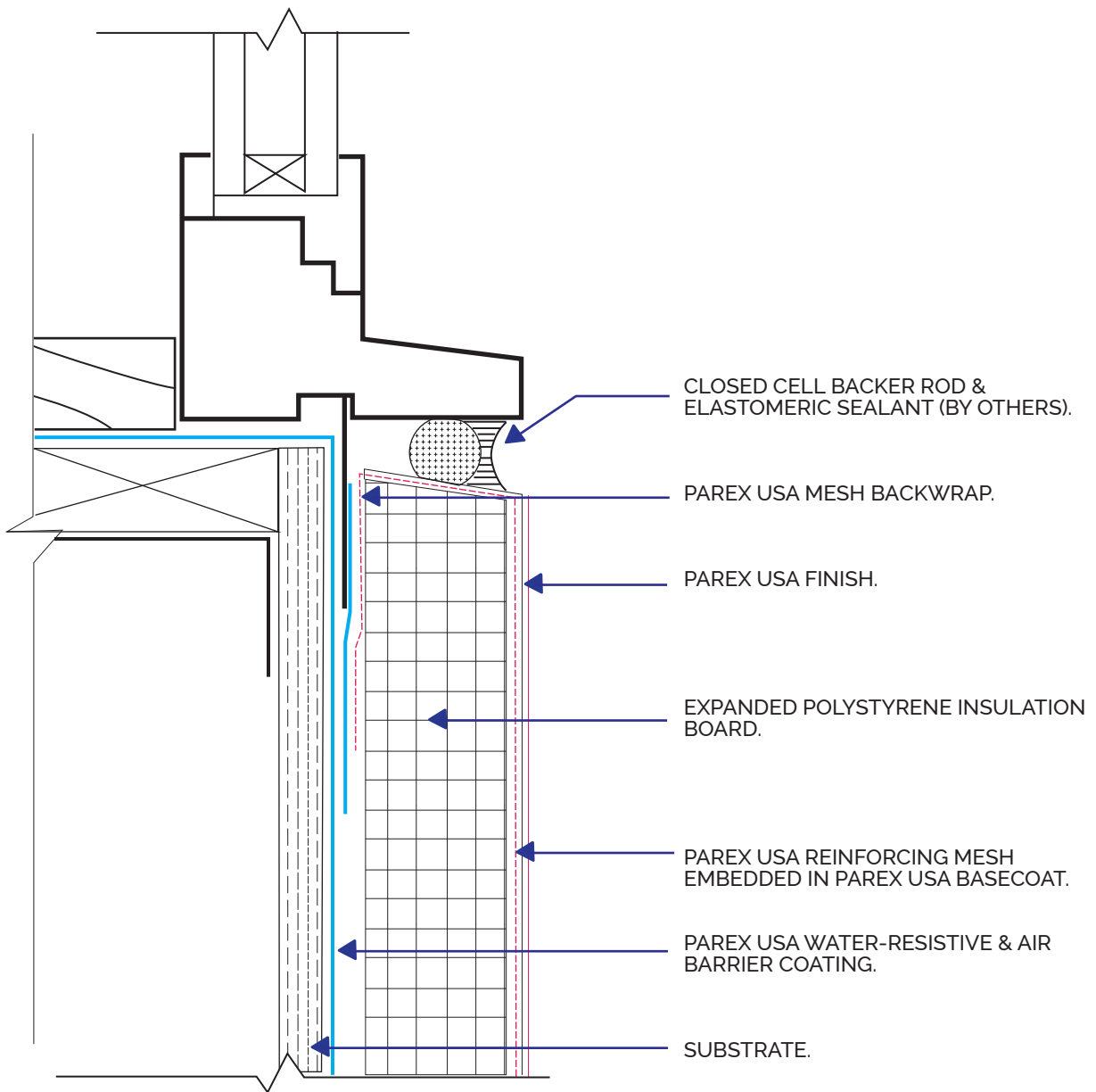

### SWM WL.06 TERMINATION WITH FINNED WINDOW SILL

REV. DATE: 05/04/18

NOTES: 1. To ensure a continuous air barrier across the building envelope, a continuous air seal should be made at each substrate change, joints/gaps, penetrations and dissimilar material terminations. These must be a consideration of the designer in the overall wall assembly design.

**Disclaimer:** The design specifications and construction shall comply with all local building codes and standards. Parex USA installation guidelines are for general information and guidance only and Parex USA specifically disclaims any liability for the use of this design and for design engineering or workmanship of any project. The assembly shall be designed to prevent condensation within the assembly. The designer and the user shall provide final drawings and specifications. Products shown other than those manufactured by Parex USA are shown for clarity of the Parex USA product only. Contact the manufacturer of such other products for installation instructions.

## WATERMASTER CI

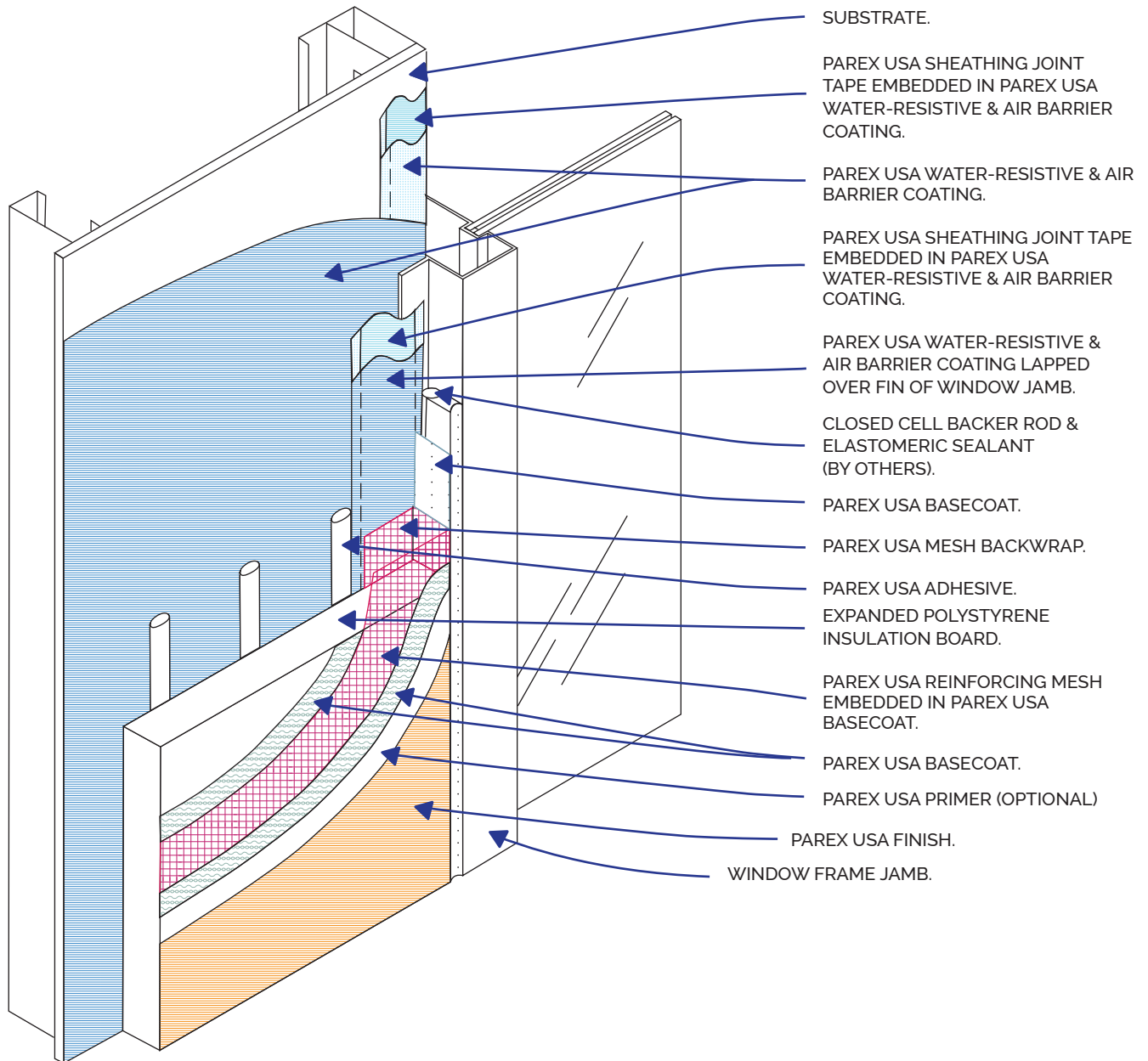

## SWM W1.07 TERMINATION AT FINNED WINDOW JAMB

REV. DATE: 05/04/18

NOTES: 1. To ensure a continuous air barrier across the building envelope, a continuous air seal should be made at each substrate change, joints/gaps, penetrations and dissimilar material terminations. These must be a consideration of the designer in the overall wall assembly design.

**Disclaimer:** The design specifications and construction shall comply with all local building codes and standards. Parex USA installation guidelines are for general information and guidance only and Parex USA specifically disclaims any liability for the use of this design and for design engineering or workmanship of any project. The assembly shall be designed to prevent condensation within the assembly. The designer and the user shall provide final drawings and specifications. Products shown other than those manufactured by Parex USA are shown for clarity of the Parex USA product only. Contact the manufacturer of such other products for installation instructions.