

**Packet Guide**  
**City of Charlottesville**  
**Board of Architectural Review**  
**Regular Meeting**  
**January 18, 2023, 5:30 p.m.**  
**Hybrid Meeting (In-person at CitySpace and virtual via Zoom)**



**Pre-Meeting Discussion**

**Regular Meeting**

**A. Matters from the public not on the agenda [or on the Consent Agenda]**

**B. Consent Agenda**

**1. Meeting minutes February 15, 2022 and March 15, 2022**

**C. Deferred Items**

**2. [Certificate of Appropriateness](#)**

BAR # 22-09-03

1301 Wertland Street, TMP 040303000

Wertland Street ADC District

Owner: Roger and Jean Davis, Trustees

Applicant: Kevin Schafer/Design Develop

Project: New apartment building/existing Wertenbaker House c1830

**3. [Certificate of Appropriateness](#)**

BAR # 22-10-02

101 East Jefferson Street, TMP 330190000

North Downtown ADC District (contributing)

Owner: First United Methodist Church

Applicant: William L. Owens, AIA

Project: FUMC solar panels

**D. New Items**

**4. [Certificate of Appropriateness - Demolition](#)**

BAR # 23-01-01

207-211 Ridge Street, TMP 290029000

Ridge Street ADC District (contributing)

Owner: The Salvation Army

Applicant: Erin Hannegan / Mitchell-Matthews Architects & Planners

Project: Phased demolition of two, c1960s buildings.

**E. Other Business**

5. Prelim. Discussion: 747 Park Street (misc. rehabilitations)

6. Staff questions/discussion

- CLG annual report – BAR training
- DT Mall NRHP listing and work group update
- Cafe space – catenary lights (if time allows)

**F. Adjourn**

**BAR MINUTES  
CITY OF CHARLOTTESVILLE  
BOARD OF ARCHITECTURAL REVIEW  
Regular Meeting  
February 15, 2022 – 5:00 PM  
Zoom Webinar**



Welcome to this Regular Monthly Meeting of the Charlottesville Board of Architectural Review (BAR). Due to the current public health emergency, this meeting is being held online via Zoom. The meeting process will be as follows: For each item, staff will make a brief presentation followed by the applicant’s presentation, after which members of the public will be allowed to speak. Speakers shall identify themselves, and give their current address. Members of the public will have, for each case, up to three minutes to speak. Public comments should be limited to the BAR’s jurisdiction; that is, regarding the exterior design of the building and site. Following the BAR’s discussion, and before the vote, the applicant shall be allowed up to three minutes to respond, for the purpose of clarification. Thank you for participating.

**Members Present:** Cheri Lewis, Breck Gastinger, James Zehmer, Jody Lahendro, Ron Bailey, Clayton Strange, David Timmerman, Robert Edwards, Hunter Smith  
**Staff Present:** Patrick Cory, Jeff Werner, Robert Watkins, Remy Trail  
**Pre-Meeting:**

There was a discussion regarding the Albemarle County Courts building project. Staff went over the details of the Albemarle County Courts and City Courts complex. The BAR got a preliminary introduction to the project this past summer. Staff went over the project for the new members of the BAR. The Chairman did recommend that the new members of the BAR provide their feedback for the courts complex project.

Mr. Zehmer had a question regarding the timelines of COAs. The timelines for COAs with the City of Charlottesville is 18 months. Staff did clarify the language and timeline for COAs approved by the BAR.

Staff did provide the distinction of contributing and non-contributing buildings and structures. Non-contributing buildings can be demolished.

**A. Matters from the public not on the agenda**

No Comments from the Public

**B. Consent Agenda** (Note: Any consent agenda item may be pulled and moved to the regular agenda if a BAR member wishes to discuss it, or if any member of the public is present to comment on it. Pulled applications will be discussed at the beginning of the meeting.)

**1. Certificate of Appropriateness**

BAR 22-02-01  
617 Park Street, TMP 520186000  
North Downtown ADC District  
Owner: Lucy Taurel and Alex Bassett  
Applicant: Adelle Chenier  
Project: Play structure

**2. Certificate of Appropriateness**

BAR 22-02-02  
413 Ridge Street, Tax Parcel 290136000  
Ridge Street ADC District  
Owner/Applicant: Michaela Lieberman and Benjamin Martin  
Project: Fencing and landscape

**3. Certificate of Appropriateness**

BAR 22-02-03  
511 N 1st Street, TMP 330001000  
North Downtown ADC District  
Owner: Charlottesville Towers Condo Assoc.  
Applicant: Robert McGinnis  
Project: Alterations to main entry.

**4. SUP Recommendation**

BAR 22-02-05  
207 14th Street, NW; TMP 090070100  
Rugby Rd-University Cir-Venable ADC District (non-contributing)  
Owner: University Limited Partnership  
Applicant: Bill Chapman  
Project: SUP to allow use as a hotel. (currently apartments.)

**Ms. Lewis moved to approve the Consent Agenda. (Second by Mr. Bailey) – Motion passes 9-0.**

**C. Deferred Items**

**5. Certificate of Appropriateness**

BAR 21-10-04  
310 East Main Street, TMP 28004100  
Downtown ADC District  
Owner: Armory 310 East Main, LLC  
Applicant: Robert Nichols/Formworks  
Project: Facade renovations/alterations

**Jeff Werner, Staff Report** – Year Built: 1916. In 1956 the north façade was reconstructed. The existing north façade was constructed in 1982. (South façade may have been built at this same time.) District: Downtown ADC District Status: Contributing (Note: When the district was established, all existing structures were designated contributing.) CoA request for alterations to the Main Street (north) and Water Street (south) facades. The proposed work will alter the 20<sup>th</sup> century facades. *See Appendix for comparison of October 2021 submittal and present submittal*

**Discussion and Recommendations**

The original, 1916 facades no longer exist. The proposed alterations will replace the contemporary facades constructed in the 1980s. The November 1980 National Register nomination of the Charlottesville and Albemarle County Courthouse Historic District does not include this address, nor do any of the building descriptions for this block match the current design. Unless the building [the facades] are of *exceptional importance*, it does not meet the 50-year threshold necessary for consideration for the National Register.

<https://www.dhr.virginia.gov/historic-register/>

A Property that can be Nominated for Listing in the Registers should:

- Have achieved historical significance at least 50 years prior to today and/or is of exceptional importance; and
- Is associated with at least one of the following:
  - o An important event or historic trend;
  - o A significant person whose specific contributions to history can be identified and documented;
  - o An important architectural or engineering design; or it represents the work of a master; or it is a distinguishable entity although its components may lack individual distinction;
  - o Has the potential to answer important research questions about human history (most commonly these properties are archaeological sites); and
- Retain physical integrity through retention of historic materials, appearance, design, and other physical features.

There are two questions for the BAR to discuss:

1. Do the existing facades—together or singularly; as part of the mall or as a single structure; and due to age, design, architect. and/or other factors—contribute to historic character of the Downtown ADC and should they be protected? (Emphasizing that an ADC District is a City designation, and not dependent on state or national designation.)
2. If the facades are to be altered--together or singularly—are the proposed changes consistent with the ADC District Design Guidelines?

Additionally, due to the unique nature of the existing facades, the BAR might consider applying components of the design standards for both *New Construction* and for *Rehabilitation*.

The applicant has not specified the glass to be used. The BAR may request that information or address it as a condition of approval. In the Appendix is a summary of BAR's July 17, 2018 discussion re: glass.

**Robert Nichols, Applicant** – Our current project is 310 East Main Street. It's the building that currently has Vita Nova Pizza on the ground floor. It has a 1970s era curtain wall façade with very thin aluminum framed-in glass on The Mall side. In addition to a style that has been exhausted, they are in dire need of maintenance. That same description holds up for the Water Street façade. The building is about 22-23 feet wide. It goes all the way through the block from The Mall to Water Street.

In October, 2021, we brought this project before the Board and reviewed our strategies for redesigning/redeveloping/rebuilding both front and back facades. We had a good discussion and a positive response. We're back this month for two reasons. One is the front (East Main Street façade). It has currently has an elevator shaft that is visible on the street. It is a convex circular shaft. We know that it is going to revert back to a flat panel that is coplanar with the face of the building. It is just a blank panel. We're not interested in seeing the elevator shaft the way it is now. It is a blank slate. We've considered it a blank slate for the decorative treatment. It already comes with a great proportion being three stories high and 8.5 feet wide. In our schedule, we asked for a deferral to give us more time to develop that. It wasn't necessarily coordinated with the rest of the other construction on the building.

What we showed last time was a 'composition in two dimensions' where we were experimenting with a little bit of relief. We had some bars in contrasting material that populated that vertical façade in varying rhythms. We got there by composing within this narrow vertical rectangle a collection of elements that produced some pleasing proportions. We have been working on a more systematic approach to creating a decoration on that façade. What it relies on are many small pieces of metallic

finished material that will come in many varieties of shape. The view on the right is a computer generated view. It's a perspective used to explain this thing. It is an array of tiles or little angle clips where the tiles go up in a regular array. They have certain parameters, which vary across the system. Each tile is flat against the elevator shaft. There's an angle where that tile is bent and it projects from the elevator shaft. The length bent tab varies and the angle the tab is bent varies. Working with that is a palate. It gives you an opportunity to develop, by the combination of these many small pieces, very interesting visual effects from a static piece of architecture that will appear very dynamic and very interesting depending on the position from which you're viewing it, your rate of speed as you walk by it, and a function of what daylight is doing at the time. If you look closely at this piece on the right, it may be not easy to identify any given tile that has an angle that is different from its neighbor. If you look at the whole piece, you can see a graphic move at the scale of the whole building where you get this river of that contrasting color coming down through the middle of that. In this case, the contrasting color will be the flat backing surface of the elevator shaft. That's going to be a very thin bronzish color. These studies on the left are different demonstrations of ways in which repeated small moves (the similar material adjusted in a similar way) in combination in the aggregate create an effect that is commiserate with the scale of the whole assembly. The ability to do this is made possible with (CNC) manufacturing abilities which is a computer numerical control. This would be less interesting and prohibitively expensive if each of these pieces was made by hand. This whole system allows for the work that we do here in our design studio to defining how these tiles relate to one another, their angles, and tab lengths. We can send that information directly into the CNC machine shops that will produce the multiple tiles in an automated way. Given this ability to make these subtle changes over many different tiles laid out in an array such as this, we are using mathematical formulas to account for the effect of one course of these being stacked on another. How do you change the variation as you go to each one? How do you adjust that variation to change course? The parameters can adjust according to what course they are on. The means of producing this and how it is derived is mute once it is an object. It gives us access to an affect and result that would be hard to achieve. The effect will be quite interesting. One of the comments about this particular panel from the last meeting was that we might consider integrating lighting into this panel. We have considered that. We had considered it before. We have decided not to do that for a couple of reasons. Since this is up against the elevator shaft, we have very little depth available to us. We don't have the kind of depth we often like to exploit to conceal lighting. We didn't want to make lighting that needed to steal depth from inside the elevator shaft. It would introduce a need to maintain that from inside the shaft, which was unappealing to us. We have had some results on the Mall, particularly going back to when we designed the Blue Light Grill many years ago where we invested a lot of time in trying to develop a subtle lighting effect that looked pretty great in our mockups. When we got it installed, it was overshadowed/overpowered by the street lighting. We realized that a lot of what is happening particularly from two stories down is that street lighting illuminates that zone through people walk. Lighting, other than interior lighting, can have a tendency to be washed out. In this case, we're relying on the backing material to reflect light. When somebody passes by and the varying degrees to which the bronze material is revealed, that would have an effect of showing the brightness and reflecting some color.

When we came back from the last meeting, there were a couple of comments that we wanted to focus on. We were hoping to come back with the response to those comments. There is a fair amount of depth in this façade (in the depth of the framing members and the depth that is provided by the kind of primary frame around the tall glazing compared to the actual sash). We also have increased depth in that vertical panel on the left over the street number. We were talking about what some sun control might do on that façade both to control the sun for the benefit of the occupants but also for the appearance of the façade. Sun control is a real issue down there from an interior perspective. What opportunities do we have on the exterior of the building? We evaluated some common ways to address southern sun; horizontal planes that project out from the building and become visors over the glazed

openings on the south. We also realized that, in this particular location, late afternoon sun should beam down Water Street from a low angle. That is also problematic. Low sun typically comes from the west. It takes a different strategy to combat that. We had horizontal blinds and vertical blinds. We're calculating sun penetration into the building. It quickly became apparent that, given the width of this building (22 feet), we have about 21 feet of occupiable space back here. The length of the floorplate is about 250 feet. There is quite a lot of action we're evaluating and proposing of the exterior of the building to improve and fine-tune the experience at this patch of floor on the interior. We found that the investment in exterior blinds on the building wasn't going to be the right way to combat sun. We have integrated on the interior positions for automated roll down shades. In the vertical tower overlooking the doorway, we're suspending that single steel mesh screen, which act as a sun shade. This is strong enough that it also acts as a safety guardrail. Operating windows and doors at that location can be opened and provide ventilation and a little connection to the street without having to add guardrails.

## **QUESTIONS FROM THE PUBLIC**

Nu Questions from the Public

## **QUESTIONS FROM THE BOARD**

**Ms. Lewis** – My question is about the windows fenestration on The Mall side. You're showing glazed. What would that look like?

**Mr. Nichols** – There will be a film on it as part of the energy development of it. I don't know in what way we have standardized the criteria for windows on The Mall; whether it is visible transmission. I am aware that there have been issues in the past about vision and tinting. If there are technical standards, we would conform to those standards. We're happy to provide samples.

**Ms. Lewis** – Our guidelines for new construction in two different places say that glass should be clear. Opaque, spandrel, or translucent glass could be approved. Darkly tinted or near glass is not appropriate. The unique thing about this building is that it was pretty much demolished. There's no historic fabric on this building. It is so unusual on the Downtown Mall. I think that gives the applicant a little bit more leeway. We're not looking at existing transoms, openings, or a structure. It was made into this huge wall with this round elevator tower and not much more. We do need to adhere to the guidelines. Where the guidelines might be silent or might equivocate, we have more leeway with this application than we do with a lot of other buildings. If this was any other building on The Mall, it would be a very different consideration.

**Mr. Werner** – On the last page of the staff report, I inserted a paragraph. Back in the summer of 2018, there was a request from the Planning Commission for how the BAR defined clear glass. We have been using this as the VLT percentage of not lower than 70 percent. There are so many different numbers that can be used to measure glass. This is the one the BAR had come down as the point. If you go below 70, the glass starts to become a mirror with the primary concern being the street level. You want to have those be permeable spaces into the shops and restaurants. You don't want people looking in a mirror. Back in 2018, the BAR had a discussion about this. It gave itself some latitude and some instruction on understanding that there is other criteria that can be evaluated. It doesn't always have to be at the 70 percent VLT. At Dairy Central, there are some windows where they went to 62 VLT. We had a difficult time discerning the difference between the 62 and the 70. There is some latitude there. The primary conclusion of the BAR was open for flexibility, provided there's a design intent behind it and provided there is an explanation of why.

**Mr. Nichols** – I always think of the tradeoff between visibilities with energy performance. Typically beefing up the energy performance can fight that. The climate condition that is best combatted with the beefed up film is solar penetration. Being on the north side of the building, we really don't have that problem. We're certainly not specifying a specific tint or mirror effect. I would be happy to provide samples. I think you will definitely perceive it as clear and clean glass.

**Mr. Timmerman** – I am having a hard time with the 3-D image. I understand that you're looking at a bronze background. With the break metal that's on top of that, is the idea that would be thin slivers of metal that are broken up with sharp angles?

**Mr. Nichols** – At the base and going up to around seven feet, those pieces probably wouldn't qualify as break metal in terms of thickness. It probably would qualify as bent plate. The angle at which they're broken would be relatively shallow. They don't project so much. Their coursing would be taller (six inches a piece). Those bits are relatively stout and there are fewer of them. Those would have their corners touched by an abrasive to soften them up. They reveal the angle at which they are broken. It would be a quite subtle five degrees. There would be a reveal of around three quarters of an inch or something like that. Once we get above that human occupancy zone, those parameters would adjust consistently with not needing to worry about vandalism or safety. That would allow for a shorter coursing, more of a reveal, and probably thinner materials.

**Mr. Timmerman** – On the right hand side, it is hard to tell from the renderings what to make of the storefront and if that is a typical storefront assembly or if there is something specific custom about it. I would be interested to hear more about that, as well as the brick selection that's surrounding. Is there something particular that led to that colored brick? I would be interested in hearing about the intent on that.

**Mr. Nichols** – That diagrammatic wall section describes the glazing system. The main idea there is that we have one masonry opening which is at the taller story. The two upper stories populate a single, taller masonry opening with the division between floors two and three. It's going to be detailed in color and geometry in a way that suggests a steel or metallic system. It has a structural appearance. It looks like the shallow side of an open steel channel. The glazing system itself is relatively conventional. We're using that intermediate spandrel condition there that will be in the same finish to try to extend the reading of the storefront so that it spans across floors two and three in a system that looks more integral to the building than just a storefront insert.

With the brick, we are just happy to use a modular size, which is what we're showing here. We and our client were interested in contrasting with the red brick down there. We want to drop a sample off. We're definitely proposing a neutral grey. That one image shown on our print submission/digital PDF isn't very compelling. We will go for a more uniform, cleaner selection.

**Mr. Gastinger** – Your elevations shows it as a lighter grey/green color. The perspective is a darker grey. The sample is somewhere in between. Your drawings also seem to suggest a darker, mortar color. What is the most representative of your intention?

**Mr. Nichols** – All of these ways of representation end up having varied effects. I would say that it is a darkened version of the elevation. The rendering is a little muddier and more shadowy than what we expect to bring to you as a sample. That printed picture is the kind of ranging in color and effect that they're allowing on the brick, to my eye is darkening that up. To the extent that there is green coming through in the elevation, that's incorrect. We would be much more neutral.



**Ms. Lewis** – What is going on right at the bottom of the façade? I don't see materials specified there. It looks like something vertical is happening below the storefront window at the entrance.

**Mr. Nichols** – That's still the brick masonry in an alternate bond pattern. I see that there's a conflict between the elevation and the rendering. The rendering has that more correct. It's the same material laid up in a sojourn.

**Ms. Lewis** – It looks like it is doing two different things side by side.

**Mr. Nichols** – The three dimensional rendering on the right is correct. The left implies something at a different scale going horizontal. It's the brick of the same size/same specification.

**Mr. Lahendro** – Despite your detailed description of the CNC metal screen, I'm still having a hard time understanding what I am reviewing. What is it going to look like? You're creating a pattern with the CNC program as it is cutting out this screen? If that's the case, what is the pattern? Is it a tight matrix-type of pattern? Is it something else?

**Mr. Nichols** – The best I can do at the moment is to revert back to the view on pg. 5. At the moment, we haven't yet locked it in. It's very hard to show in print. Coming from the east/from the amphitheater at the Mall, the effect of the pattern would largely be invisible until you get within five feet. The direction that the blinding effect happens. It obscures the contrasting color in the back. Coming from the right, you would see the effect of this pattern more. It's an abstract pattern. It's intended to utilize the full three stories to have a building scale pattern where there is some continuity of the visible bronze color all the way down. If you look at that mockup, you start to get rivers of the bronze color coming through. There is an infinite amount of possibilities. We haven't sent it to the fabricators and to our client that we have locked it in. With this view, if you something interesting or legible and if I was to rotate it, your understanding of that pattern would change. It would look different.

**Mr. Werner** – This can maybe help the BAR. It almost seems to be a sculptural piece. You can think of it as a three dimensional mural. In that case, there's a way of thinking this through, as not necessarily the design of it, but the location. The design doesn't matter. As far as the installation at this location and what the result of the artwork might be, you step away from that. The other piece is just that (lessons learned from the Code Building), some of the metal panels that are at the street level. I am not suggesting you treat it as a sculpture. It is one way to think about it.

**Mr. Lahendro** – How will you, as the architects, be sure that you're getting what you want. Are you going to be doing a mockup of this and reviewing it on site? If so, can the BAR have the ability to also review it? I would like to know what it is we're reviewing and being asked to approve. Clearly, you also don't know at this point.

**Mr. Nichols** – That's correct. There will be mockups at a relatively small scale to demonstrate other aspects of this that are essential to its construction and performance but don't describe the scale. You can learn a lot from the live, three dimensional modeling of it. That's how we're working on it. I would be happy (in the same way you review a mockup) to share with you our final review of this thing in that same way. We can emulate being at street level and having a cone of vision that starts to incorporate the full building façade and adjust for position. I appreciate your question and would like to offer that. I am describing something live, which might be difficult to coordinate. Our technology would let us deliver that as a series of frames/a video so we wouldn't have to join together for something like that.

**Mr. Lahendro** – I just bring up my own difficulty/my own hesitance in approving something that I don't know what it's going to look like. Maybe the rest of the BAR members are willing to accept it on faith. We go through an awful lot of trouble requiring mockups of traditional/conventional construction. This is something new that I have seen before the BAR.

**Mr. Nichols** – I could prepare a video or even a series of still images. It would do a much better job than a physical sample portion of it describing/making pretty clear the effect. I know pretty closely what we want. I may have been able to present to you with twelve images that would have given you an idea.

**Ms. Lewis** – I would just like to request a little bit more information about the materials. Are they going to be fragile? Will they damage? Will they be at the pedestrian level? You have mentioned bronze. We know there's metal. I would just like to see the thickness. I think that I might have to see some sort of sample of this. The video would be great to capture the image of what you're trying to do.

**Mr. Nichols** – Along with the brick, we can submit a sample of three tiles of representative size; the fattest ones we expect to see at the base, something in the middle, and one of the finer ones from the top. We expect them to be painted aluminum. The bronze would be very thin; for the most part completely protected material.

**Mr. Bailey** – How are the tiles attached to the bronze?

**Mr. Nichols** – The tiles will have blind fasteners. As an assembly, the thing goes up in panels of six courses each. It would be assembled offsite. Those panels will go up in a more conventional way as if they were an opaque piece of glass in a glazing system. All of the fasteners would be concealed on the backside of that.

**Mr. Strange** – Those will be the same material on the fenestration?

**Mr. Nichols** – The glazing system on the building proper side of that will be fairly conventional.

**Mr. Gastinger** – What is the max projection of one of those small tiles?

**Mr. Nichols** – At the moment, I am showing them at three inches.

## **COMMENTS FROM THE PUBLIC**

No Comments from the Public

## **COMMENTS FROM THE BOARD**

**Mr. Gastinger** – It's a given that there's some concern about what exactly we would be approving. We're definitely going to want to see a brick sample and some samples of this screen material and an animation of some sort to understand the fact.

**Mr. Strange** – This screen is a real interesting dynamic on a re-interpretation of the leading program you get with brick. In that respect and given the size of the module, it's a nice contemporary take on the kind of materials that are used on The Mall.

**Mr. Timmerman** – I agree with that. It’s a really good idea. The number of questions that you have already received about what it is doing points to the fact that we’re interested in it. I question it because I think it’s a great idea. I want it to be really great. I’m looking at the image of your rendering and precedent images beside it. That’s very telling. The precedent images that you presented here really do show that moire effect very well. For me, the moire effect is all about this sleight of hand. At some point, you might look at something and it looks bland. The sun or moon comes out and you’re faced with this really striking contrast and this really beautiful pattern. Whether it is one bolt strike or a wave or on the other end of the spectrum and it is a very subtle screen-like effect. My feeling about the rendering that you have provided is that I am squinting and not quite feeling something there. These precedent images are maybe physical models that you can do with a CNC machine if this is a CNC project. I don’t know if there’s a way to miniaturize it and make it something that we can look at. I’m very interested to see more study on it. I am assuming that’s where you’re heading anyway when you talk about nailing the thing down. The other thing that I would like to mention, as far as the front façade goes, I am also interested in a little bit more detailing on the windows. With some of those elevations, it would be helpful to see the context that the building sits in; not necessarily that I would have to see direct relationships. I am interested in your comment about it being a proportional project. I am interested in see how the proportions of the façade relate to what is on either side, especially given the fact that’s how we experience of walking down The Mall. In thinking about the screen, I would like to see more variety or something with the window patterns. This goes back to the guidelines. There’s a decorative pattern to a lot of the precedents along The Mall. As we walk down The Mall, there’s the copper, metallic canopies that we look at and admire, the detailing from the 20s and 30s. There’s some more contemporary detailing that catches our eye. This is pretty neat that this is a detailing and decorative project. I would like to see how that pushes a little bit more in the window wall. In questioning the intent behind the solids versus the glass, you mentioned that the idea there was for a singular opening, singular aperture. When you mentioned that, I saw it. The big band going across it breaks it up or works against that singularity a little bit. I am interested in where the numbers are; the 310 and the joint of the glass. There is an interest there that I would like to see spread out to the other typical storefront patterns that happen everywhere else around. There’s a huge opportunity with the screen. This goes back to Ms. Lewis’ original comment about how this is a tabular rasa. The historic context was brutally ripped out of this thing. There’s a great opportunity here to bring back some ‘ghosts’ of the old detailing of years past on The Mall.

**Ms. Lewis** – We haven’t talked about the Water Street side. I don’t have any objections to it. It meets our guidelines. My concerns and focus are on the transparency of the glass on The Mall. I am happy that the brick color is more nuanced and you provided a sample that gives a little bit more color than the elevation was shown. I am interested to see the color of the mortar and more details as other people have said including surrounds. I think the screen is pretty cool. It’s a great innovation. It’s a much better solution than what you had before us in October. It can be fantastic. We need more information about the materials and how it would work and what you were going to spell out in the moire. I am concerned about how these openings relate to existing buildings on the Downtown Mall. The first two guidelines under New Construction definitely ask us to looking at buildings’ openings, rhythm of voids and masses, and proportions and make sure those are similar to adjacent or nearby structures; maybe some elevations, maybe showing us anything in that block. It doesn’t have to be fancy. These three stories don’t strike me as being out of character. They do seem to have more of a commercial than other buildings traditionally do on The Mall. I am really supportive. It looks like a neat project.

**Mr. Gastinger** – I am really supportive of the project. The way that you have approached these facades has been really successful. I really like the elongated proportions. They’re an appropriate, contemporary response to the condition that you found. There are a couple of concerns about the panel. My concern is the great, elegant, and long proportion. I hope that it is not detracted from the treatment

you have to give the pattern in the lower 7 to 8 feet. I just worry that could get really flat and less interesting. I hope it wouldn't feel like a different material in that portion. I'm not convinced by the effect in the rendering. I am concerned that the really beautiful/white ones are using the white material and it is all indirect light that creates shadow and creates a lot of contrast. What you're proposing is using dark colors on a north façade. It's not going to have direct sunlight. The potential is there for it to be exquisite. I'm not yet convinced by what you have shown us. The proportion of the depth of relief that you are working with is much less than the small little paper models of the other examples that you're showing. I'm hoping it doesn't feel two dimensional or underwhelming for the effort it is taking to create it. In the earlier elevations, the bronze color was really helpful in setting itself off against that primarily dark grey façade. I'm worried that we're losing that color. If it was more like the rendering, it would be very dark. Maybe that lighter brick is helpful. There have been a few questions about the windows and the storefront system. In many cases, we don't require as much information regarding that. In this case, the storefront is essentially almost the entire façade. It is well within our purview to understand more about that system and the glazing that would be included.

**Mr. Nichols** – You're talking about the Main Street side and how it ties in with the spandrel?

**Mr. Gastinger** – How much detail is included in that section where it is the two inch piece and the glass and the character of that glass.

I know that you put this up for final COA approval this evening. There are no questions about samples and details. Do you have any comment about where you are in the process?

**Mr. Nichols** – We're pretty far along. We have in our office the information about the storefront, scale, and what is going on with the storefront as it goes to the spandrel in the back. We understand here that it would be fairly easy to get to. The development of the screen is ongoing. The remaining questions would be addressed and approved in 'one swoop' without setting aside bits and pieces to come back or to be reviewed as samples in the conference room. With the general construction and design schedule, we need to keep going. It seems pretty clear from your comments today that what is happening, in terms of our choice of systems and basic structural conditions and material choices, it is very easy to isolate out the panel as off the construction schedule. I really don't see that holding up our general work on the project. I would expect to be able to come back roughly eight weeks from now. We will be working on our construction documentation in the meantime.

**Mr. Gastinger** – What I am hearing is general support for the direction and approach with some questions about some of the details, samples, understanding that there is a longer timeframe, and finalizing the construction of the panel. Do we have enough information to approve the panel tonight? I know that we also have challenges in how we could come back approve that at a later date.

**Mr. Werner** – There are a couple of things that we need to clarify. One is the glass. Do you have something in mind? Is 70 VLT something that you want? That would be information provided by the company that does the storefronts. The second piece that we need to clarify is the difficulty with having renderings versus elevations. We get details that are slightly different. I noticed at the rear elevation that I can't tell if things are supposed to align or if it is the way the rendering has it presented. An actual elevation in lieu of a rendering is probably preferable to make sure that we see all of the details. It does seem like there are some material samples that you all want to see; the front screen and the material in the back. I clearly hear support. I don't know how you would phrase this unless you have strong opinions or you want to make some clarifications about the renderings so that we're clear about what is understood.

**Mr. Gastinger** – We’re getting more guidance from the city attorney and city staff about limiting or not allowing COAs with extensive conditions. We’re limited in our ability to come back approve COAs in a piecemeal fashion. It would certainly be my preference to approve this at a later date. We need a little bit more information to exactly understand what we’re approving.

**Mr. Nichols asked the BAR to defer the application to a later date – Mr. Zehmer moved to accept the deferral. (Second by Mr. Gastinger). Motion passes 9-0.**

## 6. Certificate of Appropriateness

BAR 21-07-05

350 Park Street, TMP 530109000 and 530108000

North Downtown ADC District (non-contributing property)

Owner: City of Charlottesville and County of Albemarle

Applicant: Eric Amtmann, Dalgliesh-Gilpin-Paxton Architects [on behalf of Albemarle County]

Project: New courthouse building (at Levy Building)

**Jeff Werner, Staff Report** – 350 Park Street Year Built: Levy Building 1852, Annex c1980

District: North Downtown ADC District Status: Contributing 0 Park Street Year Built: N/A, parking lot District: North Downtown ADC District

Status: N/A

The Levy Building is Greek Revival, constructed with brick laid in American bond with Flemish bond variant. Three stories, hipped roof, three-bay front, heavy entablature supported by monumental stuccoed pilasters on brick pedestals, crossette architraves, and brick water table.

CoA request for construction of an addition to the Levy Building and new construction related to the expansion of the City-County Courts Complex.

### Discussion

**While this is a formal CoA request, the applicant has acknowledged that this meeting will be treated as an intermediate review, that the applicant will request a deferral, and no formal BAR action will be taken, except to accept that request.** However, by consensus the BAR may express an opinion about the project as presented. (For example, the BAR may take a non-binding vote to express support, opposition, or even questions and concerns regarding the project’s likelihood for an approved CoA. These will not represent approval or even endorsement of the CoA, but will represent the BAR’s opinion on the project, relative to preparing the project for final submittal. While such votes carry no legal bearing and are not binding, BAR members are expected to express their opinions—both individually and collectively--in good faith as a project advances towards an approved CoA.) This is an iterative process and these discussions should be thorough and productive. The goal is to establish what is necessary for a final submittal that provides the information necessary for the BAR to evaluate the project and to then approve or deny the requested CoA.

In response to any questions from the applicant and/or for any recommendations to the applicant, the BAR should rely on the germane sections of the ADC District Design Guidelines and related review criteria. While elements of other chapters may be relevant, staff recommends that the BAR refer to the criteria in Chapter II--*Site Design and Elements*, Chapter III--*New Construction and Additions*, and Chapter VI – *Public Design and Improvements*.

Of particular assistance for this discussion are the criteria in Chapter III:

- Setback, including landscaping and site improvements
- Spacing
- Massing and Footprint

- Height and Width
- Scale
- Roof
- Orientation
- Windows and Doors
- Street-Level Design
- Foundation and Cornice
- Materials and Textures
- Paint [Color palette]
- Details and Decoration, including lighting and signage

Also, the criteria under *Public Buildings and Structures*, in Chapter VI

- Public buildings should follow design guidelines for new construction.
- New structures, including bridges, should reflect contemporary design principles.

Additionally, the BAR should consider Sec. 34-282(d). While the provision identifies what is *required for a submittal*, the BAR has historically applied this list with discretion, given that not all are necessary for every CoA request.

- 1) Detailed and clear descriptions of any proposed changes in the exterior features of the subject property, including but not limited to the following: the general design, arrangement, texture, materials, plantings and colors to be used, the type of windows, exterior doors, lights, landscaping, parking, signs, and other exterior fixtures and appurtenances. The relationship of the proposed change to surrounding properties will also be shown.
- 2) Photographs of the subject property and photographs of the buildings on contiguous properties.
- 3) Samples to show the nature, texture and color of materials proposed.
- 4) The history of an existing building or structure, if requested by the BAR or staff.
- 5) For new construction and projects proposing expansion of the footprint of an existing building: a three-dimensional model (in physical or digital form) depicting the site, and all buildings and structures to be located thereon, as it will appear upon completion of the work that is the subject of the application.

**Steve White, Applicant** – We have been diligently advancing the design inside and outside for the last six months. Our intent tonight is to show you what we have progressed with and with our plan to come back a third time for design with regards to more granular detail. Tonight’s presentation is divided into four sections. The sections are the history, site context analysis, the building design, and materials/materiality.

### **First Slide**

To orient everyone to the site, north is up. We’re looking at the parameters of the building site. We have Park Street on the west/left, High Street to the north, the Jessup House (county owned property) to the east/right, and we have East Jefferson Street to the south. We have the Redlands Club in that southwest corner. There is a 1980s addition that will be demolished as part of the project. What will remain is the original Levy structure from 1851 (top left corner).

### **Next Slide**

The history of courts complex starts in 1803 with the building that’s on the right hand side (that cluster of two building facades). It was added onto a few times at least one hundred years. The façade you see there was 100 years after the original one was built. It is a wonderful, cultural resources that you have

in Charlottesville. It will be the circuit court and remain as the circuit court when this project is finished. The project we're discussing tonight is a lower court (General District Court). The building to the left is the 1938 addition. It was originally an administrative office building. It was converted to courts. It will have the remainder of the circuit court/higher court functions going on in that structure.

### **Next Slide**

These pictures are giving you some historical research that we have been diving into over the last year. The Redlands Club (top right corner) is noteworthy.

### **Next Slide**

Understanding the context of the region and of the Shenandoah.

### **Next Slides**

We did fly a drone over the site. We used that to do investigative work related to façade restoration. We had them here to get a good birds-eye. This is looking west. The next slide is looking east. You can see on the top portion the Levy Building on the left and the 1980s addition (that will come down). The Redlands Club is hidden by a tree.

### **Next Slide**

These three slides certainly are very important to us in the makeup of the character, proportion, scale, and the identity of this campus as a courts campus, a judicial facility made up of four structures. The fourth structure is the new structure. That's important for us in keeping in mind how we figure out the identity of this new structure.

### **Next Slides**

These next two or three slides are just the street views.

### **Next Slide – Site Analysis**

This is just a sampling of the things that we were looking at. We looked at traffic patterns, those sheds to the site, and new sheds from the site, the site topography, solar orientation, etc.

I included in the package three to four pages of written narrative. The intent there was to provide you with a narrated response. I encourage the Board to read through that. It does go through carefully the comments we received and our response to those comments.

### **Next Slide**

This is our current site plan. There are a couple of things I want to point out about the site plan. As we get further into the discussion, the building is made up of a series of building forms. The forms are really driven a lot by the function that is within because we have large courtrooms. There are two large courtrooms. They make up the primary building mass. We have a series of "saddlebags" that support that primary mass with building, judge's chambers to the north. We have the building entrance and portico. We have the hyphen/connection to the Levy Building. They are a contextual response to the building masses that are adjacent to our property; the lengths of walls, heights of walls, and where the

steps occur. You will see that as we go through this. The other piece to this site plan that I want to point out is that we, since the first presentation, the entry plaza is really our most important space. It's a public space, outdoor space that is essentially an outdoor room as framed by two buildings that are 150 to 200 years old. The third side is the new building/entry portico. That really becomes the place where you meet your associates, your attorney before going in, there are serious discussions before going in, and there are serious discussions after coming back out. This is intended to be a place of calming and respite and to be a civic space that is indicative of the gravitas of the court system. That's what is going on.

### **Next Slide**

The blue areas are the public spaces. Behind those blue spaces are the functional areas like the clerk's offices and their highly trafficked spaces. They're on the first floor. The Commonwealth Attorney is in the Levy Building. They take up the entirety of the Levy Building. You enter the main portico at that center portion where the elliptical form is. If you're meeting with the Commonwealth Attorney, you would actually turn left and make your way to the Levy Building. There are stairs that flank the north and south ends of the building. Those are also expressed on the exterior and help break down the scale of the mass of the building.

### **Next Slide**

This is where the most important functions of the building are. You go up through a double rotunda space into this linear corridor that feeds the two courts. One is the county general district court and the other is the city general district court with the judge's chambers to the north.

### **Next Slide**

This is the roof plan. We do have a mechanical screen. It has been deeply recessed from the primary elevation to be discrete and functionally moved off of the edge of the courtrooms to mitigate noise that occurs as a result of the units.

### **Next Slide**

We're going to shift to the portico. These are traditional porticoes that reflect civic, government, or academic functions. The bottom three are all courthouses either at the state or federal level, which are modern interpretations of those traditional porticoes. These are some of the things that we looked at the design of the front entrance.

### **Next Slide**

We also carefully studied the proportions of the facades of the buildings, particularly the buildings that are part of the courts complex. The Levy, Greek revival is on the top left, the 1803 original structures' additions from the 1870s and 1890s (an ionic order), and the bookended brick walls.

### **Next Slide**

This is a rendering of that entry plaza. You can see that it is a formal symmetrical space, framed by the Redlands Club on the right and the Levy Building on the left. The portico is a modern expression in steel and glass. There are honey-locust trees, which frame the left and the right and create nice dapple light/shade for benches that are left and right. With the elliptical form, we have studied it quite



extensively and we're still studying different patterns for that elliptical form. On the end that is facing you, it creates the building signage but also separates the ADA access on the right from the stair access on the left as the site slopes right to left.

### **Next Slide**

These are studies of the elliptical form; all predominantly in brick with highlights in bluestone. We have not settled on a particular pattern. We are investigating various patterns in design right now.

### **Next Slide**

This is a colored rendition of the plan of that space. You can see the six trees. We previously had two on either side. We have now pushed the building back about 17 feet and added an additional honey locust to create a better proportioned outdoor room in a more ceremonial space.

### **Next Slides**

This is a diagram illustrating the ADA accessible routes.

### **Next Slide**

These two sections illustrate the benches and the trees and the site walls.

### **Next Slide**

The building forms have been deliberately kept low. It is a two story structure that sits approximately 35 feet such that no portion of the new building is taller than the cornice line of the Levy Building.

### **Next Slide**

In terms of the rhythm of that front façade, the last time you saw this it was a five bay order running across the entirety of that saddlebag. We have changed it to an ABA rhythm with a three bay order in the center with bookends left and right. It works well for us in terms of the function and the interior with queuing and screening. From a scale point of view, the relationship to the Levy Building was working better to create a 'sibling' of the Levy Building that is somewhat of a reflection.

### **Next Slide**

This is a detail of how the portico/the way we're thinking of the detailing at this time. It is a galvanized, architectural finished steel. It means that the welds are done to a certain level of quality. There's no writing on the steel. It is very clean. If you galvanize and paint it, it can be a very nice finish. The anti-room is a roofed space. That's where your weather-lock is. It's nested internal to that larger element. The muttoned portion would be clad. It would be an aluminum clad storefront system that would not be the exposed steel.

### **Next Slides**

This is the north side up on High Street with the Levy Building on the right and the addition that will be removed on the left. This next view is the design of the new structure. You can see that saddlebag that is the judge's chambers. It is very similar in scale to the Levy Building in its dimension (left to

right) and in that direction. You have the setback to the left with the recessed panel and the garage entrance. One thing to keep in mind with the courthouse is that there's very specific functional criteria. We have a sally port for detainee transfer going down the ramp into a secure space. It's also a secure zone for the judges and chief clerks to park. That was a very important functional requirement. That is tucked away. It also aligns with the face of the Jessup House on the left.

### **Next Slide**

This gets into the detailing of the brick. Our intent here is to finesse the façade with very subtle details and to not overplay our hand and to be somewhat differential to the historic structures and to beget the detailed in proportions that are really nice. The steps in the façade are 2 to 4 inches depending on where you are. Those primary pilasters are all two inch changes in plane. The entablature is a series of corbels. There is cat stone that is intentionally a similar color to the brick as not to create a heavy striation that can be distracting. It's also indicative of the function of the courts so that the courts are on that upper level. You have very tall ceilings there. That's the reason for the really tall window.

### **Next Slide**

This is the elevation from the east. That's the Jessup House in the foreground. It is by enlarge covered. That building is about 10 to 15 feet away. Since you last saw it, the façade has been broken into an ABABA rhythm rather than one long strip of windows and pilasters. We thought that it broke it up nicely. It also is indicative of the two courts. There is a court on the left, a court on the right, and a space between. You can also see the subtle saddlebags. The saddlebag on the right is the judge's chambers. You can see how that cornice line is picked up. There's no parapet wall. There are pretty subtle steps that are occurring on and around the façade.

### **Next Slide**

This is the north elevation with the Levy Building on the right, the hyphen on the left. You can see how much lower that hyphen is from not only the main structure but also the saddlebag of the chambers. The long element between the hyphen and the element on the left is the stair. That stair egresses out to grade. That expression is slightly different. The window is at the landing. We're just trying to create some interest and some variation to help mitigate the fact that we have a pretty large institutional building across the street from a residential neighborhood.

### **Next Slide**

This is the south façade. You can see the Redlands Club in the 'ghosted' thing on the left with the Levy Building behind it. You can see the relationship of the portico in the weather lock to the saddlebag of the entry element. That element has windows according to the interior arrangement. That proportion is very in keeping with the townhouses that are nearby. There are a couple of slight recessed panels between the stair and the entry element on the left.

### **Next Slide**

This is an aerial view of the site from the south and east.

### **Next Slide**

These are the materials. We have three brick blends we're studying right now, all with darker mortars. An example is the national building museum where it uses the sandstone, a red brick, and a red mortar as a way to differentiate it from its neighbors. We're also using a Norman brick. The trim colors are in that last slide. It is a blueish-slate color that we think works nicely with the brick. It is also a departure from the white trim, mutton windows that are predominant.

### **Next Slides**

These are slides showing materials for the exterior plaza spaces.

### **QUESTIONS FROM THE PUBLIC**

No Questions from the Public

### **QUESTIONS FROM THE BOARD**

**Mr. Strange** – Can you talk more about why you're using mimicry and a single material to mimic the classical forms of the adjacent building and is the correct approach here?

**Mr. White** – We were intentionally not trying to use mimicry. There was the intentional use of other materials to avoid mimicry.

**Mr. Strange** – There is so much use of a single material. I find it odd/strange that you wouldn't make better use of contemporary ideas about brick in order to address the kind of classical language in a new way. It seems to me like a one-to-one relationship between what is existing and what you're proposing and using brick as 'paintbrush' to do that.

**Mr. Zehmer** – I thought that I had read the penthouse on the roof was 'if needed.' Is that needed?

**Mr. White** – It is absolutely needed. If it was written as 'if needed,' that was an error on our part.

**Mr. Gastinger** – Can you remind us what the nature of that screen will be?

**Mr. White** – It would be a metal panel that would likely be in a vertical orientation. It would be abut seam. There would be no shadow line. It would likely be the same tone as the blue-grey of the window trim.

**Mr. Lahendro** – No natural light in courtrooms. The only natural light in the building is going into the hallways that ring the building. Is that just the way it is with courtrooms and court buildings? Just the lack of windows? It looks like a fortress. It's just a lack of transparency, penetration. It's hard to believe that courtrooms can't have natural light. Were you in the program not allowed to put natural light in the courtrooms?

**Mr. White** – This is a very astute question. I appreciate you asking it. There will be light in the courtrooms. There will be a clear story light that will be high somewhat similar to the city district court. There is a clear story there. It is essentially a security and egress driven issue. I don't know if you're aware of how a modern new courthouse works. There are three essential elements. There's the public, the judiciary, and the detainee. They're all three separate circulation routes that can never cross, except for in the courtroom itself. They are very much a driver. I recently designed a courthouse for the federal courts that did have windows on the edge. The way you achieve that is by having extra stairs in the back in order to not have to the circulation wrap around. We could do that here if we had more

site. That was something we tried to achieve at one point. We're really hemmed in by the size of the site to be able to get that. I am sensitive to this issue and realize that the judges and clerks spend most of their days in these rooms. To have natural light in them is really important.

**Mr. Zehmer** – Is a skylight a viable option?

**Mr. White** – Yes. It could be a viable option.

**Mr. Gastinger** – I don't see any clear story windows in the building facades. Where is the light coming in?

**Mr. White** – Do you see the 16 foot dimension? Those windows are about 12 feet tall. That's a clear story in that upper portion.

**Ms. Lewis** – What is the remaining material on these windows? What would be called fenestration but they're not clear story that would bring in natural light?

**Mr. White** – Just regular vision glass. That tall window is all clear vision glass.

**Ms. Lewis** – It is clear vision glass? There's no natural light coming in it? I am not familiar with clear vision glass. Can you describe what that is?

**Mr. White** – Did I say that there was no light coming in?

**Ms. Lewis** – I thought that you had said that only the top, rectangular, horizontal windows would be the windows letting in the light. That was a clear story.

**Mr. White** – The question was I don't see any clear story windows. Show me the clear story. I was pointing out where the clear story is. When we say vision lights that means that they're lights that you can see through. They're clear. From the floor to 12 feet above the floor is a large window, which includes that horizontal band, which is called a clear story. All of them contribute to the light that goes into the courtroom.

**Ms. Lewis** – There is a lot of natural light that goes into these courtrooms.

**Mr. White** – The confusion was that there was a corridor. The corridor is on the exterior. It is part of that security requirement. It bounces light into the courtroom itself. The courtroom itself has bands of light that are high.

**Mr. Timmerman** – Can you explain the front portico as it is designed? It looks like the vertical columns are disengaged from the portico below. It is like two separate structures there. The columns are outside the glass and the one story box below.

**Mr. White** – That's correct.

**Mr. Timmerman** – Nothing really happens up there. That's a solid roof above the first story. The second story canopy is just a decorative element. It is not to be occupied at any time?

**Mr. White** – The roof/brise soleil would filter light for the second story of that atrium/lobby space with the views out to the western site, the circuit court.

**Mr. Timmerman** – Is my interpretation of those windows is that it would be like a thin mutton steel fenestration?

**Mr. White** – I would call it a steel aesthetic.

**Ms. Lewis** – I have a question about this new space that you called a ‘weather lock.’ What was the origin of that that is new on this iteration? I am wondering how that came about.

**Mr. White** – One thing we did was reduce the size of the mass of the entire structure, most of it being in that lobby sequence. Previously, that whole weather lock piece was essentially the first 17 feet of the entire building, which contained the queuing. What we have done is push the atrium inward. We still wanted a weather lock because it is very functional and it can get quite cold. It’s not good for energy use to not have a weather lock. This was essentially get us back to the weather lock in doing it in a different expression.

**Ms. Lewis** – What was the reason that the building was reduced by that 17 feet?

**Mr. White** – Inflation has gone up by 20 to 30 percent for construction. That was a mitigating factor to still meet the program and to still have a good building.

**Mr. Strange** – Can you talk about the way the new construction connects with the Levy Building?

**Mr. White** – There’s currently a hyphen that’s there now. That hyphen currently engages with the cornice. There’s a railing up there for maintenance workers. The cornice is really jammed into the other cornice. What we did was align the hyphen in plan so that the hyphen puncture into the Levy Building is exactly the same spot. We’re not making any different hole in plan. In elevation, we’re going down in order to restore that cornice all the way across.

**Mr. Lahendro** – The Levy Building historic entrance and the way the architecture is designed to emphasize the entrance to the current building; that will no longer be an entrance?

**Mr. White** – It will no longer be a public entrance.

**Mr. Lahendro** – It will be a private entrance for the Commonwealth Attorneys and for the staff?

**Mr. White** – Yes. As they see fit.

## **COMMENTS FROM THE PUBLIC**

No Comments from the Public

## **COMMENTS FROM THE BOARD**

**Mr. Zehmer** – I feel that the building as a whole is too monochromatic. It’s just a huge block of red. I was wondering if there might an opportunity. You said the trim of the windows was a blue slate color. I didn’t know if even some detailing on the window sills would break up the big mass of red. (Page 169) I worry about having this muttoned enclosure with such small panes of glass; feels like a cage. I would be worried that someone who is innocent until proven guilty would not feel comfortable walking through there. We will definitely want to look at details with the penthouse. With our guidelines with rooftop screening, units should be screened from public view. Screening design and

materials should be consistent with the design, textures, materials, and colors of the building. Screening should not appear as an afterthought or an addition to the building. Right now, it is very schematic and conceptual. That's what our guidelines say when you get to detailing that. It's never an easy thing to do. With the portico, I respect the departure from that. I was intrigued by your precedent images. I wonder if there's an opportunity to make that have a little more 'pizazze.'

**Mr. Strange** – I would echo what you said about the portico. I think the precedents have more to offer. I appreciate the contemporary take on the portico. There is a degree of governmental transparency embodied by the examples that you showed that is lost here in the way that the fenestration is very similar if not exactly the same behind the portico. The weather lock occupies the entire portico. I feel that the purpose of the portico is to create an indoor/outdoor space. When the weather lock is in that space, it almost negates the functionality of the portico. I know it is a delicate game to be deferential but to also not be unremarkable. When I look at the image of these two buildings together, there's no question that the new building is not competing with the Levy Building. It's not very "exciting." The materiality of the portico looks very dark. It shrinks compared to the size of the overall façade. It's not doing the kind of things that the porticos do on some of the examples you showed in terms of creating a nice surface or a moment of engagement with the building, the public space. I am echoing the notion that the portico could do a lot more to engage this public space a little more effectively. I wonder if using the same architectural language to connect to the Levy Building is the right approach. This is a building of many masses. I wonder if the mass connects the existing building to the new building and should be articulated in the same way or if it should have a different kind of connection that really lets us know that it is a connection and creates a buffer zone between the new building and the old building.

**Mr. Bailey** – Part of the thing with the portico is that people are complaining that the portico that the applicant offered the first time was too big. The applicant has shrunk it and it's now too small. He may have offered a smaller portico because people thought it was too big the last time.

**Mr. Gastinger** – There has been some improvement in the way that the rooflines and the volumes of the buildings have been clarified. That was part of it. It was not just the size of the portico but its relationship to the adjacent roofline. I definitely hear the commentary on the portico and the concern about the cage-like reading of a steel façade and tightly grained fenestration. My big concern is the unremarkable-ness of the rest of the building. I am very distressed about the direction that the building and its detailing has come. The lack of any differentiation in the material leads to a reading from me of a really big brick box with the least amount of detailing possible to get it passed the BAR. It's not proportional to the scale of the building. It's not using detail in a way that breaks down the building to make it feel more approachable from a pedestrian standpoint. The facades on High Street are really disasters. Because the foundation has the most minimal treatment, it is a full nine foot tall brick wall with no differentiation. You have chosen this way using classical proportions to modulate the building. The detailing is so skinny and so thin. It's not very proportional at all in the way visually to the weight a cornice should have with the shadows it would cast. Maybe it doesn't need to be a different color. If so, it seems like it needs to have a thicker, deeper proportion to create the kind of differentiation you are hoping for. While I appreciate budgetary concerns, this is a building we hope to be living with for the next 100 years. It is underwhelming. It is really difficult to imagine. This is something that is really important to the county and the city. The community deserves a better approach to these facades that are going to be there for a really long time.

**Mr. Lahendro** – I concur with what Breck has said. I am especially disturbed by the High Street elevation and the pedestrian lack of experience on High Street. This is disastrous.

**Mr. Strange** – I suspect the approach of using brick as a mono-material is an attempt to make this not just a complete copy of something classical. I wonder if there aren't other ways to use brick that are not super-classist that might relate to classical proportions but could imbue the façade with different textures. Just throwing this out as a way to possibly move forward. I respect the desire to not just make a classical building. If it has to have these different materials and follow these classical forms, how do you do that?

**Mr. Gastinger** – I agree. Some of the examples that were shown as precedents offer some ways of doing that. I think bringing in more of the gray-blue of the steel of the entry portico into some more of the detailing. That could be a way of offering/improving the articulation of the structure, even with its current modulation. Things that Mr. Strange is mentioning, either with the hyphen or with the foundation, give it more depth.

**Mr. Timmerman** – I am new to this. I was given the images of the previous submission. I noticed on High Street that there used to be windows at eye level. Is there a programmatic reason why you took them out?

**Mr. White** – We do have some programmatic function in the basement. It is mostly sunken. We may have been exploring that at one point to try to get some eye level windows into this surface space down there. We can certainly look at ways to modulate the water table course to give it some interest and create some more visual interest to the façade.

**Mr. Timmerman** – I will reiterate what the other board members have said. While High Street is not the front of the building, it's really important to all of us. The whole site is really important. We live in a small city without a lot of real estate. These projects don't come along very often. When they do come along, we really want to capitalize on them and not end up with something that is underwhelming. In that particular location, we all have experienced walking around the Levy Building. As you walk around that building and walk down High Street, we want something else there. We're not looking for background. There's a certain amount of focus that needs to be paid to that elevation beyond what the current expectation is. Underwhelming came up for me when looking at the front portico. Looking back at some of the previous project renderings, I favor the older one more than this one. This one seems diminutive. It almost seems residential in scale. While I appreciate the sensitivity that you're going for as far as breaking up the massing and I appreciate opening up the public space in the front, seeing that elongated was good. You're left with this little contraption on the big red brick building. It looks like an added on appendage. The original design/the front started to create its own pattern and its own texture; maybe breaking up the rest of big block behind it. I really liked Clayton's idea about the transparency that we're looking for in these kinds of public buildings. The idea of a portico is a first step to bridge that gap between the inside and the outside. That diminutive appendage that is there now seems to be more of a barrier.

**Ms. Lewis** – I wanted to thank the applicant for two things that were achieved from the last iteration. One is this weather lock/vestibule area. We had noted that we wanted a place where litigants, attorneys, and other people coming to court would be gathering. I know the creation of this space was a response to those comments. With the breakup of that huge wall on East Jefferson Street, I really appreciate the windows that have been inserted in the detail and how that is articulated in that it wraps around to Seventh Street on the other side. I actually wished we had seen some of this with this slate/blue accents that you're talking about; whether they be lentils, window surrounds, or whatever that looks like. It might have addressed some of the comments that my colleagues have about the solid brick. The brick samples you have given us would make the building a whole lot different than what it looked like in some of these renderings. It would be great to see that and what that looks like. I have a

real problem with the High Street side. Fifty feet long of nothing but nine feet of brick with nothing else is not going to happen. High Street is an entrance corridor. It is designated as a very important corridor in our city. That is not going to fly for any of us. I was disappointed to see that. I understand that the garage entrance needs to be there. There has to be more detail on that. I understand that's programmatic. I will definitely add support to the other comments about the portico. I know it sounds like we're giving mixed messages. The width was reduced. The depth was also brought in. That's one of the things that makes it unremarkable. It could be quite remarkable. The portico is a face on the building. This is not a very pretty face. I really regret that there's no natural light in either of these courtrooms. There's a way to figure that out. This is not a federal court. Half of the cases heard in these courts will be civil cases. There are no detainees in civil cases. There is no separate corridor in any of the four local courts. The detainees are brought in the same way that public enters. There are things we need to think about. This is not a prison. My last comment is about this weather lock. I completely agree with James' comments. We have to look at the separation. It looks like a cell to me. It looks like a place I don't want to be. The idea of having something that insulates people from the elements is very appealing. It's a really important building for us.

**Mr. Gastinger** – There were a number of sheets dedicated to the plaza. That has developed nicely. It seems flexible with the changes made to the portico. I would encourage the design team to think carefully about the amount of brick in that plaza, especially given the comments about the amount of brick in the façade. I would also encourage the design team to continue to make sure that the detailing allows for enough soil volume to make sure those three trees thrive in a pretty hard surface.

**Mr. Strange** – On the Mall, they use a utility brick for the plaza. That's one way to think about differentiating the plaza and buildings.

**Mr. White moved to request a deferral. Ms. Lewis moved to accept the deferral request. (Second by Mr. Zehmer) Motion passes 9-0.**

**The meeting was recessed for five minutes.**

#### **D. New Items**

##### **7. Certificate of Appropriateness**

BAR 22-02-04

540 Park Street, TMP 520183000

North Downtown ADC District

Owner: Jessica and Patrick Fenn

Applicant: Ashley LeFew Falwell / Dalgliesh Gilpin Paxton Architects

Project: Raze pool house, construct new; addition and alterations to house.

**Jeff Werner, Staff Report** – Year Built: 1900 District: North Downtown ADC District Status: Contributing, including two outbuildings: garage and pool house. (Note: While designated contributing, the pool house was constructed between 2000 and 2002. See images in Appendix.) 540 Park Street is a two-story asymmetrical wood house with a Doric veranda. Constructed by William T. Vandergrift for the Maphis family. Wood siding was covered in stucco.

#### **Application**

- Applicant's submittal: Dalgliesh Gilpin Paxton Architects narrative (two pages) and drawings (15 sheets, including five sheets from Wolf Josey Landscape Architects) for 540 Park Street, dated January



25, 2022. Request for demolition of existing pool house, exterior alterations to rear addition, new pool house construction, and the execution of a new landscape plan.

### **From applicant's submittal**

Architectural Summary: The architectural plan proposes to demolish the existing pool house structure, construct a new lower profile pool house, and revise the east addition within the existing footprint. The goals of the project are to achieve a new coordinated aesthetic for the rear pool courtyard, add square footage, and improve the functionality of the existing square footage for the current owner.

Front of House:

- Removable screen panels are proposed for the southwest portion of the existing front porch.

Back of House:

- Overall, the new architecture around the rear pool courtyard of the house will be thoughtfully considered, holistically designed, and will result in improved functionality for the owners upon completion. The architectural language of the altered east addition and new pool house will be modern, rendered in colors and high-quality materials that are compatible with the main house, but not intended to imitate the house stylistically. The stucco exterior walls will have a smooth finish, clad metal windows and doors will be dark in color, and the roofs will be copper.

Landscape Summary: The landscape plan proposes renovations to the existing hardscapes at the front and side of the house as well as modifications to paving and planting at the back of the house to support the proposed architectural changes.

Front of House:

- Existing crushed stone paths will be realigned and replaced with stepping stones in lawn. The north path section will be removed and replaced with lawn.
- The crushed stone landing in the front of the house will be paved in bluestone and raised slightly for drainage purposes.
- The steps down from the front porch will be rebuilt to adjust to a revised landing elevation. Stair treads will be lengthened.
- An existing black walnut along the street is in poor health and is proposed to be removed.
- The front lawn will be regraded to a more gentle pitch. A new stone seatwall at the west end of the lawn will retain approximately 12" of soil.

Side of House:

- Pathways and hardscapes on the south side of the house along Farish Street will be upgraded and paved in bluestone or brick.

Back of House:

- Paving along the back and east side of the house will respond to the architectural changes and match or complement existing paving.

### **Discussion**

Staff recommends that the BAR refer to the criteria in Chapter II--Site Design and Elements, Chapter III--New Construction and Additions, and Chapter VII--Demolitions and Moving.

Re: razing the existing pool house: The pool house was constructed between 2000 and 2002. (See Appendix.) Staff is uncertain why it was designated a contributing structure. While a formal review will require compliance with Code section 34-2779(a), there is nothing to indicate this structure is historic or that its demolition would negatively impact the character of the ADC District. (Per 34-277(a), a CoA is required for the demolition of a contributing structure.)

For the new pool house: From G. Garages, Sheds, and Other Structures in Chapter II

- Choose designs for new outbuildings that are compatible with the major buildings on the site.

- Take clues and scale from older outbuildings in the area.
- Use traditional roof slopes and traditional materials.
- Place new outbuildings behind the dwelling.
- If the design complements the main building however, it can be visible from primary elevations or streets.
- The design and location of any new site features should relate to the existing character of the property.

For the rear addition: From the checklist for Additions in Chapter III.

- Function and Size
- Location
- Design
- Replication of Style
- Materials and Features
- Attachment to Existing Building

Additionally, the discussion should address any questions regarding the materials and components. For example:

- Roofing
- Gutters/Downspouts
- Cornice
- Siding and Trim
- Doors and Windows
- Landscaping
- Lighting

The proposed alterations to the rear addition include a new shell within the footprint of the existing addition. This rear addition was substantially altered in 2014; the second floor of the addition is older than the floor and was previously supported by columns over an open porch. In 2014, the BAR approved a first-floor addition that enclosed the porch under the second floor. It is unclear if when this second floor addition was constructed, but given these substantial changes, staff finds the proposed alterations consistent with the guidelines.

**Mary Wolf, Applicant** – For this property, we’re essentially renovating the front yard of the property and the side yard along Farish Street and creating some new landscape in association with the new pool house. The renovations along the front include removal of an existing large walnut tree that’s in poor health. We’re planning to reshape and repave the crushed stone paths in front of the house and create a new landing at the front door. We’re also proposing to regrade some of the front lawn to make it a gentler slope and more functional for the family. This is the only lawn space on the property. As part of that leveling out, we’re also proposing a stone, low wall inboard of the property by about 25 feet from the sidewalk. We’re also proposing, along Park Street, to remove the existing tall hemlock hedge that exists. It’s about 12 to 14 feet tall. We’re proposing to replace that hedge with a boxwood hedge that we would like it to ultimately be 4 to 5 feet high that you can see over. We would back-plant that with some deciduous shrubs that would allow views into the property. The house sits pretty low down from the sidewalk. It’s the only house on Park Street that has that low siding relative to the street. We feel like having a little bit of height involved along the street without blocking views is really necessary. Along Farish Street, we’re also proposing to upgrade a lot of the existing stepping stone paths. We’re also proposing to remove two large ash trees that are growing very close to the existing shed along Farish Street.

**Ashley Falwell, Applicant** – We’re looking at a zoomed in version of the site with the existing building, existing pool house. The red-hatched area is the proposed demolition. We would like to take

out an existing exterior stair on the north side of the main house and the pool house that was built between 2000 and 2002. The gray hatched areas are the new building footprint or altered footprint. We are altering the shell of the east addition of the main house. It will be within the footprint of the existing east addition. We are making some changes to the exterior. We're also showing the proposed pool house. We're really trying to create an aesthetically unified courtyard around this existing pool. These are drawings showing what is there. You can see the east addition. We are keeping that footprint; altering the lower level and extruding that footprint up to the first and second floors. This is the south view showing that addition. We are going for a bit more modern expression with this addition; trying to keep the color palate very similar, high quality materials. We're looking at a low slope, flat seamed, copper roof with stucco for the first and second floors and with a smooth finish. The existing house has a textured stucco finish, new metal clad windows and doors. The historical reference sheet for this original house references the noble and serene quality of the existing house. We're trying to carry that into the addition and the new pool house. This is the new pool house that is a low bar building to create a courtyard space and have a more modern dialogue with the east addition. It has a stone chimney, copper roof, metal clad windows and doors, and going to use some smooth stucco for the exterior walls. The last time we presented, the Board was looking for a cut sheet on windows and doors. We're looking at using Pela-reserve contemporary clad wood unit. This is the quality and detail that we're going for. We have some exterior reference shots. The bottom three show the area that we're effecting. We're looking at referencing the stone on that existing privacy wall. This is the existing pool house structure that we would like to demolish.

#### **QUESTIONS FROM THE PUBLIC**

No Questions from the Public

#### **QUESTIONS FROM THE BOARD**

**Mr. Gastinger** – Can you describe the stucco product you're thinking of using?

**Ms. Falwell** – The stucco on the main house has a significant amount of texture in it. I think we're trying to imitate that on the pool house. We're definitely looking to do something fairly smooth that's not going to have a modeled texture at all. It's more about the massing, the planes, and continuing the color that would be consistent. It's going to be true stucco.

#### **COMMENTS FROM THE PUBLIC**

No Comments from the Public

#### **COMMENTS FROM THE BOARD**

**Mr. Gastinger** – This is a huge improvement to the way that this house is presented. Thank you for that approach to lower that existing hedge and improve the visibility of this remarkable house. I find the additions really appropriate in the back.

**Motion – Ms. Lewis – Having considered the standards set forth within the City Code, including City Design Guidelines, I move to find that the pool house demolition, new pool house construction, rear addition alterations, porch screening, and landscape plan at 540 Park Street satisfy the BAR's criteria and are compatible with this property and other properties in the North Downtown ADC District, and that the BAR approves this application as submitted. Second by Mr. Lahendro. Motion passes 9-0.**

#### **E. Discussion Items**

## 8. Preliminary Discussion

0 Preston Place, TMP 050118001 (or 050118002 or 050118003)

Rugby Rd-University Cir-Venable ADC District

Owner: Preston Place Properties, LLC

Applicant: Leigh Boyes

Project: New residence

- Staff introduced the proposed project to the Board for this preliminary discussion on Preston Place.
- There have been multiple COA applications from Preston Place in the recent past.
- The applicant is proposing to build a single-family residence, three bedroom, and two stories with a mix of materials.
- The plan is to use all of the existing stone walls that used to retain the storage container on that site.
- The house will have a number of porches.
- The applicant did present a summary of what they're planning to do in terms of landscaping and plantings around the house.
- After a brief presentation from the applicant, members of the Board provided feedback and guidance for the applicant for the project.
- Mr. Gastinger had some concerns about the garage structure and the character of the garage structure.
- Mr. Timmerman brought up fitting the house into the parcel could be an interesting design and inspiration and could tell a story about the site.
- Mr. Timmerman wondered about the engagement with the neighboring house. The applicant was responsive to finding engagement with the neighboring house.
- There is a mixed bag of different styles within this neighborhood.
- The applicant does want stone elements within the house.

## 9. Preliminary Discussion

1301 Wertland Street, TMP 040303000

Wertland Street ADC District

Owner: Jeanne and Roger Davis

Applicant: Kevin Schafer / Design Develop

Project: New residential building

- The applicant presented the project proposal to the members of the BAR for their review and discussion.
- The current house is the oldest structure within the Wertland Street ADC District.
- The surface parking area on the property is the best place for the building of this new residential building.
- The plan is to keep and maintain the current historic structure as part of the proposed project.
- Members of the BAR posed questions for the applicant regarding the proposed project on Wertland Street.
- There was concern about the primacy of the garage to Wertland Street and the imposing residential building compared to the historic structure.
- Staff did remind the BAR that there are going to be more of these projects coming in front of the BAR in the future.
- Members of the BAR provided constructive feedback and suggestions to the applicant as to what can be done to improve the project proposal.

**F. Work Session (TENTATIVE – May only introduce the matter for later discussion)**

- Brief work session to go over and discuss the Zoning Rewrite.

**G. Other Business**

Staff Questions/Discussion

**Adjournment**

The meeting was adjourned at 9:57 PM

**BAR MINUTES  
CITY OF CHARLOTTESVILLE  
BOARD OF ARCHITECTURAL REVIEW  
Regular Meeting  
March 15, 2022 – 5:00 PM  
Zoom Webinar**



Welcome to this Regular Monthly Meeting of the Charlottesville Board of Architectural Review (BAR). Due to the current public health emergency, this meeting is being held online via Zoom. The meeting process will be as follows: For each item, staff will make a brief presentation followed by the applicant's presentation, after which members of the public will be allowed to speak. Speakers shall identify themselves, and give their current address. Members of the public will have, for each case, up to three minutes to speak. Public comments should be limited to the BAR's jurisdiction; that is, regarding the exterior design of the building and site. Following the BAR's discussion, and before the vote, the applicant shall be allowed up to three minutes to respond, for the purpose of clarification. Thank you for participating.

**Members Present:** Cheri Lewis, James Zehmer, Robert Edwards, Breck Gastinger, David Timmerman, Clayton Strange, Jody Lahendro

**Staff Present:** Patrick Cory, Robert Watkins, Jeff Werner, Remy Trail

**Pre-Meeting:**

Staff went over the meeting agenda. Mr. Gastinger did speak with the Wertland applicant regarding the preliminary discussion.

Mr. Gastinger had questions about the minutes from the July BAR meeting. Mr. Gastinger asked that some changes be made to those minutes.

Ms. Lewis recused herself from one of the preliminary discussion due to representing the applicant before the BAR on past projects.

**The Chairman brought the meeting to order at 5:30 PM.**

**A. Matters from the public not on the agenda**

No Comments from the Public

**B. Consent Agenda** (Note: Any consent agenda item may be pulled and moved to the regular agenda if a BAR member wishes to discuss it, or if any member of the public is present to comment on it. Pulled applications will be discussed at the beginning of the meeting.)

1. Approval of Meeting Minutes from July 21, 2021
2. Approval of Meeting Minutes from January 18, 2022
3. **Certificate of Appropriateness**  
BAR 22-03-01  
1835 University Circle, TMP 060069000  
Rugby Rd-University Cir-Venable ADC District  
Owner: Meg Conklin and John Jay  
Applicant: Mary Wolf / Wolf-Josey

Project: Landscaping

**4. Certificate of Appropriateness**

BAR 20-03-02

223 East Main Street, TMP 33023400

Downtown ADC District

Owner: Labace, LLC

Applicant: Tony Labace

Project: Replace storefront

**Mr. Gastinger made the Motion to Approve the Consent Agenda with three edits to the July, 2021 BAR Minutes (Second by Ms. Lewis) – Motion passes 7-0.**

**C. Deferred Items**

N/A

**D. Preliminary Discussions (including questions from staff)**

**5. 1301 Wertland Street, TMP 040303000**

Wertland Street ADC District

Project: New residential building

- Kevin Schafer and Design Develop introduced the project for a new residential building on 1301 Wertland Street.
- The existing lot is a large agrarian lot and the relationship with this house is an anomaly to the street.
- The driveway has disconnected the house from its historic front. There was an effort to save some large trees.
- The current house sits pretty far back from Wertland Street and still does have a drive aisle on 13<sup>th</sup> Street that cuts in front of the house.
- One of the opportunities for this property was to straighten the drive aisle and get it out from in front of the house and move the historic building towards Wertland Street.
- It would give it a presence on Wertland Street and maintain the relationship with 13<sup>th</sup> Street (its historic driveway).
- It would provide an opportunity on the rear part of the site to add a building on the rear part of the site behind the historic building.
- A precedent that the applicant to the BAR was the Varsity Hall at UVA. It was moved to a different location, repaired, and renovated.
- The applicant is seeking feedback from the BAR regarding this potential project.
- There would have to be two COA applications needed for this potential project: One for moving the historic structure and one for the new residential building.
- Staff did note that there are tax credit opportunities available for this project. Staff did recommend doing the COA applications separately.
- Members of the BAR did provide the feedback on what the applicant could do to improve the project/make the project feasible.
- There is a lot of work that has to be done to stitch this project together. The applicant wanted to make sure to have positive feedback from the BAR before starting the work.

**6. 32 University Circle, TMP 060094000**

Rugby Rd-University Cir-Venable ADC District (non-contributing)

Project: Window replacements

- Staff presented this proposed window replacement project for this building.
- The guidelines are 'silent' on window replacement on a non-contributing building/structure.
- A previous applicant from Court Square at the Monticello Hotel was asked to make a window replacement plan.
- According to Mr. Zehmer, UVA has been restoring windows on the historic buildings rather than replacing windows.
- After much discussion with staff, the BAR recommended that staff work to protect the character of those things that are historic on the building.
- The decision reached by the BAR was that any changes made to the building (window replacement) will require a Certificate of Appropriateness from the BAR.

**7. 1901 East Market Street, TMP 55A149000**

IPP within the Woolen Mills HC District

Project: Rear addition

- Staff reminded the BAR that this project should get the same attention as a contributing structure and building in an ADC District.
- Ms. Lewis recused herself due to a conflict of interest of having represented the owners of this property in previous COA applications.
- Staff presented the renderings of what the rear/suggested addition to this property.
- Staff did emphasize the importance of the roofline and elevations between the original house, the 2002 addition, and the new rear, suggested addition.
- One of the things that is successful with the 2002 addition is that there is a hyphen.
- With the proposed addition, an elaborate hyphen would be good for the proposed addition.

**8. 111 14th Street NW, TMP 090074000**

Rugby Rd-University Cir-Venable ADC District (non-contributing)

Project: Proposed Mural

- The purpose of this preliminary discussion is whether a mural would be an appropriate addition.
- One of the suggestions was to move the mural closer to 14<sup>th</sup> Street and not be as close to the door.
- The guidelines do state that there should be no painting on unpainted brick.
- There was a precedent with the painting of Heather Heyer on brick.
- One of the reasons for the applicant wanting to paint this mural is because there is currently graffiti there.
- The idea is to preclude people spray painting graffiti on this wall.
- Staff is going to recommend to the applicant that they find a different place or what the sacrificial coating does.

The meeting was recessed for ten minutes.

Staff met with the design team of the Courts Complex Project to discuss the feedback that was received from the BAR. An application for the Courts Complex Project will be submitted in April. It was a very positive meeting with the design team.

Staff is hoping to bring to the BAR next month six structures for a proposed historic conservation district. The CH Brown Historic District would be at 12<sup>th</sup> and Rosser on the north end of the Tenth and Page Neighborhood. The next step is to talk to the property owners about the architectural, character defining



features that are important. That will be coming to the BAR with a recommendation from the BAR on the change in the zoning and change to the Design Guidelines. This district is going to be in memory of Reverend Brown, who designed many houses in Charlottesville. The idea is to start with these six houses. The idea is for this to come before the BAR in April, 2022.

## **E. Work Session**

### **Zoning Ordinance Revisions**

James Freas, NDS Director

- The zoning rewrite project has begun and it is a three part project.
- The first part is the diagnostic and approach phase.
  - Staff and the consultant team is reviewing the current zoning and where the current zoning is out of step with best practices in zoning and the adopted Comprehensive Plan.
  - That approach will be documented in a report that is going to be released in the middle of April.
  - Feedback will be collected on the report and finalize the report to share with the Planning Commission and City Council by the end of June.
  - The drafting of the zoning ordinance will happen in the course of the summer.
  - The draft zoning ordinance will be released at the end of September/beginning of October.
- The next part is receiving feedback/input with a goal of a final draft of a zoning document by the end of 2022 with an adoption a year from now.
- The zoning ordinance should be an approachable and readable document. That is going to be the guiding principle going into the drafting process.
  - The new zoning ordinance will have a lot of illustrations, tables, charts, and it will use simple language.
- Staff is going to look at what role the BAR is going to play in the zoning rewrite and the ADC Districts within the zoning rewrite.

## **F. Other Business**

Staff Questions/Discussion

## **Adjournment**

The meeting was adjourned at 8:00 PM.

## **Certificate of Appropriateness**

BAR # 22-09-03

1301 Wertland Street, TMP 040303000

Wertland Street ADC District

Owner: Roger and Jean Davis, Trustees

Applicant: Kevin Schafer/Design Develop

Project: New apartment building/existing Wertebaker House c1830

Application components (please click each link to go directly to PDF page):

- [Staff Report](#)
- [Historic Survey](#)
- [Application Submittal](#)

**City of Charlottesville  
Board of Architectural Review  
Staff Report  
January 18, 2023**



**Certificate of Appropriateness**

BAR # 22-09-03

1301 Wertland Street, TMP 040303000

Wertland Street ADC District

Owner: Roger and Jean Davis, Trustees

Applicant: Kevin Schafer/Design Develop

Project: New apartment building/existing Wertebaker House c1830

---



**Background**

*Year Built:* [Likely] 1842. (Some believe c1815 or c1830, but that cannot be confirmed.)

*District:* Wertland Street ADC District

*Status:* Contributing

1301 Wertland Street--the *Wertebaker House*--is a two-story, three-bay, brick house with a rear ell. (Wm. Wertebaker was UVA's second librarian, serving from 1826 until 1880, he died in 1882.) Built in the Greek Revival style, it owes much of its appearance to renovations later in the century, when a Victorian porch was added. (In 1842, Wertebaker acquired 27-acres from James Dinsmore's estate. He immediately sold all but 6 ¾-acres, on which the house was built. By 1886, the parcel was 1.4-acres. By the 1980s, it had been reduced to 0.4-acres. See map in Appendix.)

**Prior BAR Reviews**

February 15, 2022: BAR held a preliminary discussion for this project.

Meeting video (01:22:00): [BAR Meeting Feb 15 2022](#)

Submittal: [1301 Wertland St - BAR Submittal February 2022](#)

March 15, 2022: BAR held a preliminary discussion for this project.

Meeting video (00:08:46): [BAR Meeting March 15 2022](#)

Submittal: [1301 Wertland St - BAR Submittal March 2022](#)

September 20, 2022: BAR discussion; accepted applicant's request for deferral.

Meeting video (01:22:00): [BAR Meeting Sept 20 2022](#)

Submittal: [1301 Wertland St - BAR Submittal September 2022](#)

October 18, 2022: BAR discussion; accepted applicant's request for deferral.

Meeting video (0:55:00): [BAR Meeting October 18 2022](#)

Submittal: [1301 Wertland St - BAR Submittal October 2022](#)

## Application

- Submittal: Design Develop drawings *1301 Wertland Street*, dated December 27, 2022 (41 pages).

Proposed construction of apartment building, including parking, landscaping and site improvements, adjacent to c. 1830 Wertenbaker House. [Staff note: the submittal does not address what is planned for the historic house re: maintenance, alterations, and/or rehabilitation.]

**Note:** The rendering on sheet 18 of the submittal is incorrect. Correct image is in the Appendix of this staff report.



## Materials

- Brick: Old Carolina Brick Company Handmade Brick In “Windsor.” Mortar: Argos “San Tan”
- Siding: James Hardie Vertical Board-and-Batten Siding. Painted BM “Midnight Oil”
- Trim: Smooth Fiber Cement Boards. Painted BM “Midnight Oil”
- Metal Railing: Custom. Painted BM “Midnight Oil”
- Windows: Jeld-Wen Aluminum clad, double-hung. Insulated, internal spacer bars. Color: “Sable”
- Doors: Windsor wood [French] doors. Painted “Sable”
- Doors: Jeld-Wen single-panel, steel door.
- Balcony decking: Trex Enhanced Natural Decking. Color: “Coastal Bluff”
- Garage Door: None
- Canopy near garage entrance: (See image in Appendix.) Structural c-channels around the exterior (similar to balcony detail on Sheet 37). EPDM roof. Stained wood ceiling.
- Exposed ceilings: (per applicant email) Ceilings will be exposed wood joists, stained dark, semi-transparent. (See images in Appendix.) Using *YellaWood*: pressure treated pine processed to accept staining.
- Lighting:
  - Bollards (Pemco), wall sconces (Spitzer), and strip lighting (Sonoray): Lamping is dimmable, Color Temp does not exceed 3,000K. Sconces and strip lighting have Color Rendering Index of 80. (CRI not noted for the bollards; however, they are not serving as overhead area lights.)
  - Garage ceiling (Spitzer): Lamping is dimmable; however, the Color Temp does not exceed 5,000K and the CRI is 70. (\*\* BAR has required that lamping have a CT not exceeding 3,000K and a CRI not less than 80.)
- Pathway paving: Brick. Scored concrete.
- Landscaping: All specified plants are on the City’s Master List, unless (noted).
  - Trees: Bald Cypress; Sweetgum; Yellowwood; Serviceberry; Magnolia; Ginko.
  - Plantings: Inkberry Holly; Summersweet; Witchalder [*Fothergilla*]; Oakleaf Hydrangea; Arrowwood Viburnum.

- Groundcover: Low Gro Sumac; Aronia; Liriope muscari (non-running, clumping variety; approved at 0 3<sup>rd</sup> Street, NE).
- Perennial mix: (All are non-invasive.) Threadleaf Bluestar; Switchgrass; Dwarf Joe Pye Weed; Hyssop; Coneflower, Prairie Dropseed.

## Discussion

(Attached is a comparison of current design and submittals from Feb, March, Sept, and October 2022.)

In response to any questions from the applicant and/or for any recommendations to the applicant, the BAR should rely on the germane sections of the ADC District Design Guidelines and related review criteria. While elements of other chapters may be relevant, staff recommends that the BAR refer to the criteria in Chapter II--*Site Design and Elements*, Chapter III--*New Construction and Additions*, and Chapter VI – *Public Design and Improvements*.

Staff recommends that the BAR refer to the criteria in Chapter II--*Site Design and Elements* and Chapter III--*New Construction and Additions*. Of assistance are the following criteria from Chapter III:

- |                        |                    |                          |
|------------------------|--------------------|--------------------------|
| A. Residential Infill  | F. Scale           | K. Foundation & Cornice  |
| B. Setback             | G. Roof            | L. Materials & Textures  |
| C. Spacing             | H. Orientation     | M. Paint [Color palette] |
| D. Massing & Footprint | I. Windows & Doors | N. Details & Decoration  |
| E. Height & Width      | J. Porches         |                          |
- 
- |                          |                               |                         |
|--------------------------|-------------------------------|-------------------------|
| • Roof                   | • Doors & Windows             | • Plantings/Landscaping |
| • Gutters and Downspouts | • Lighting                    | • Patios & walks        |
| • Exterior walls         | • Railings                    |                         |
| • Trim                   | • Balcony details             |                         |
| • Public spaces          | • Screening (HVAC, utilities) |                         |

## Wertland Street ADC District



Wertland Street Historic District (National Register of Historic Places)

[www.dhr.virginia.gov/historic-registers/104-0136/](http://www.dhr.virginia.gov/historic-registers/104-0136/)

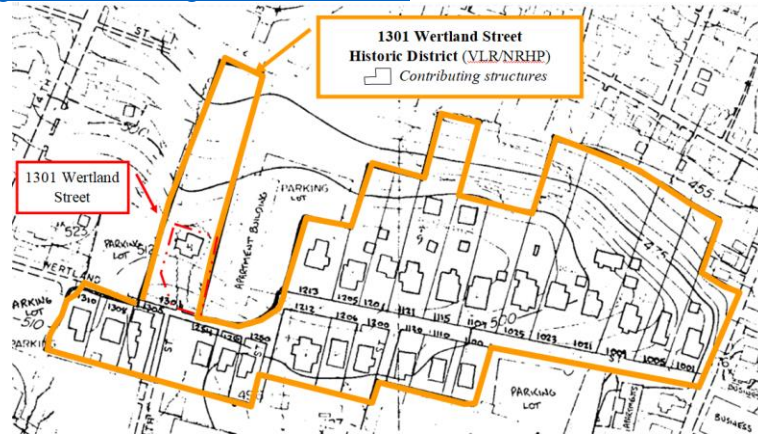

**Note:** In prior meetings it was noted that staff referred to *contributing structures* within the ADC District that are *not historic*---for ex. 1021 Wertland St, built 1999, and 1215 Wertland St., built 1965. The local district’s *contributing structures* are designated (shaded) on the City map. Note that the ADC District boundary and the *contributing structures* do not coincide with the NRHP designations.



The following summarize the BAR’s February and March discussions. In the Appendix are links to the previous submissions and video recordings of these discussions.

Summary of BAR discussion, Feb 15, 2022:

- BAR requests that architects consider the new building’s setback in comparison to the setbacks of other buildings on Wertland
- Concern that the garage entrance would be dangerous given its proximity to the sidewalk
- Height of the building is imposing. Breaking up the building mass may make it less imposing
- Materiality may break up the building mass, perhaps by using darker colors
- Stepping down building as it reaches Wertland Street may break down mass

- Relate building height to the cornice line of historic house
- Concern over the busy-ness of the new building's elevation facing Wertebaker House: too many competing elements
- The site offers an opportunity to build something that frames or accentuates historic building

Summary of BAR discussion, March 15, 2022:

- General support for moving historic house. It would improve street wall and visibility of the historic house
- Scheme would require two BAR applications: one to move house and a second to build new structure
- Fact that house would remain on original parcel supports case for moving it
- Request to more deeply investigate skewed footprint of Wertebaker House; compare it to historic maps
- BAR comments that by moving historic house, more attention paid to it and opportunity to rehabilitate it for new use
- Urban conditions have changed so drastically around Wertebaker House that skewed footprint is not important to retain. If moved, house should have new relationship to street
- Important to distinguish between design decisions intended to complement historic fabric and design decisions intended for good urban design and better pedestrian experience

Summary of BAR Discussion September 20, 2022:

Meeting video (begin at 1:22:00):

<https://boxcast.tv/channel/vabajtzeuyv3iclkx1a?b=nvdouryu5aooh1orqwx>

Summary of BAR October 18, 2022:

Meeting video (begin at 0:55:00):

<https://boxcast.tv/channel/vabajtzeuyv3iclkx1a?b=uzjzbhfohchjty5hs6f>

Staff comments and recommendations:

- Note: This will be the fifth time the BAR has reviewed this proposal. Given the BAR's direct involvement in the evolution of this design, in the following staff's goal is to be succinct and not, unless warranted, revisit or comment on every aspect of the project. (For example, ideally a garage entrance would not be so prominent on the primary façade; however, the location has been consistent throughout this review and the BAR has not recommended against it.)
- The proposed spatial elements are consistent with the recommendations of the design guidelines. (See staff comments below, under **highlighted** items from Chapter III – *New Construction and Additions*.)
- The proposed materials are consistent with the recommendations of the design guidelines.
- No alterations have been proposed for the house; however the BAR might discuss with the applicant: how the house will be protected during construction activities; [baseline] documentation of the house prior to construction; any alterations or maintenance that might be necessary, planned, or anticipated; and etc. (In reviewing the SUP for 612 W. Main Street, the BAR recommended that the adjacent Holsinger Building be seismically monitored during construction. Council included in the SUP a condition requiring the owner to *prepare a Protective Plan* for the historic building.)

- The historic porches, railings, and steps on the house are inaccurately portrayed in the applicant’s renderings. The BAR should establish that the renderings are illustrative only and no alterations to the house have been proposed, nor are any being reviewed and/or approved.
- The lighting inside the garage has lamping with a Color Temp that exceeds 3,000K. Glare has been a problem with some LED lighting and on other projects the BAR has expressed concern re: the exterior impacts of seemingly interior lighting. Either alternate fixtures can be requested, or a condition of approval might require that the owner addresses any later, glare-related issues.
- Relative to the site, the Design Guidelines incorporate by reference the Secretary’s Standards for Rehabilitation, which recommend that archeological resources will be protected and preserved in place. If such resources must be disturbed, mitigation measures will be undertaken. For some projects, that BAR has recommended an archeological investigation of the site. Given the significance of this site and its association connection to two prominent individuals associated with the University (Werthenbaker and Dinsmore), staff recommends a Phase I archeological survey be conducted prior to any site disturbance, with the results submitted for the BAR record.

**Suggested Motions**

*Approval:* Having considered the standards set forth within the City Code, including the ADC District Design Guidelines, I move to find the proposed new building at and related alterations to 1301 Wertland Street satisfy the BAR’s criteria and are compatible with this property and other properties in the Wertland Street ADC District, and that the BAR approves the application [as submitted].

Or, [... as submitted] with the following conditions:

*Denial:* Having considered the standards set forth within the City Code, including the ADC District Design Guidelines, I move to find that the proposed new building at and related alterations to 1301 Wertland Street do not satisfy the BAR’s criteria and are not compatible with this property and other properties in the Wertland Street ADC District, and that for the following reasons the BAR denies the application as submitted: [...].

**Criteria, Standards, and Guidelines**

**Review Criteria Generally**

Sec. 34-284(b) of the City Code states that, in considering a particular application the BAR shall approve the application unless it finds:

- (1) That the proposal does not meet specific standards set forth within this division or applicable provisions of the Design Guidelines established by the board pursuant to Sec.34-288(6); and
- (2) The proposal is incompatible with the historic, cultural or architectural character of the district in which the property is located or the protected property that is the subject of the application.

**Pertinent Standards for Review of Construction and Alterations include:**

- (1) Whether the material, texture, color, height, scale, mass and placement of the proposed addition, modification or construction are visually and architecturally compatible with the site and the applicable design control district;
- (2) The harmony of the proposed change in terms of overall proportion and the size and placement of entrances, windows, awnings, exterior stairs and signs;
- (3) The Secretary of the Interior Standards for Rehabilitation set forth within the Code of Federal Regulations (36 C.F.R. §67.7(b)), as may be relevant;
- (4) The effect of the proposed change on the historic district neighborhood;



- (5) The impact of the proposed change on other protected features on the property, such as gardens, landscaping, fences, walls and walks;
- (6) Whether the proposed method of construction, renovation or restoration could have an adverse impact on the structure or site, or adjacent buildings or structures;
- (7) Any applicable provisions of the City’s Design Guidelines.

## **Pertinent ADC District Design Guidelines**

### **Chapter I – Introduction**

Links: [Chapter 1 Introduction \(Part 1\)](#) and [Chapter 1 Introduction \(Part 2\)](#)

#### **5. Wertland Street ADC District**

*Subdivision of four large lots in the 1880s provided the impetus for the development of this University-adjacent neighborhood. It survives today as one of Charlottesville’s best examples of vernacular Victorian domestic architecture. Queen Anne, vernacular Victorian, foursquares, and Colonial Revival residences with a variety of gabled, hipped and complex roof forms, large dormers, porches, and porticos line the street. Many of the larger residences have been converted to student housing with parking in the front yards, however, the district retains its residential character.*

*Primarily mid-to-late nineteenth century, 2 to 3 stories, large lots, predominantly shallow setbacks, narrow spacing, brick, slate and metal roofs, older apartment building, large scale infill apartment buildings, front site parking, mature landscaping, overhead utilities, cobra head lights, low stone walls, ornate metal fencing, large parking lots, hedges, concrete retaining walls, small planted islands, smaller lots.*

### **Chapter II – Site Design and Elements**

Link: [Chapter 2 Site Design and Elements](#)

#### **A. Introduction**

[...] Many of the nineteenth century dwellings in the North Downtown area and along parts of Ridge and Wertland streets also have limited setbacks and are spaced closely together. In these cases there are small front yards composed of grass or ground cover and often containing large canopy trees. The edges of these areas often are planted with low shrubs or flower beds, and the houses are surrounded by foundation plantings. Iron fences, hedges or low stone walls may separate the homeowner’s property from the public sidewalk.

#### **B. Plantings**

- 1) Encourage the maintenance and planting of large trees on private property along the streetfronts, which contribute to the “avenue” effect.
- 2) Generally, use trees and plants that are compatible with the existing plantings in the neighborhood.
- 3) Use trees and plants that are indigenous to the area.
- 4) Retain existing trees and plants that help define the character of the district, especially street trees and hedges.
- 5) Replace diseased or dead plants with like or similar species if appropriate.
- 6) When constructing new buildings, identify and take care to protect significant existing trees and other plantings.
- 7) Choose ground cover plantings that are compatible with adjacent sites, existing site conditions, and the character of the building.
- 8) Select mulching and edging materials carefully and do not use plastic edgings, lava, crushed rock, unnaturally colored mulch or other historically unsuitable materials.

#### D. Lighting

- 1) In residential areas, use fixtures that are understated and compatible with the residential quality of the surrounding area and the building while providing subdued illumination.
- 2) Choose light levels that provide for adequate safety yet do not overly emphasize the site or building. Often, existing porch lights are sufficient.
- 3) In commercial areas, avoid lights that create a glare. High intensity commercial lighting fixtures must provide full cutoff.
- 4) Do not use numerous “crime” lights or bright floodlights to illuminate a building or site when surrounding lighting is subdued.

[...]

#### E. Walkways and Driveways

- 1) Use appropriate traditional paving materials like brick, stone, and scored concrete.
- 2) Concrete pavers are appropriate in new construction, and may be appropriate in site renovations, depending on the context of adjacent building materials, and continuity with the surrounding site and district.
- 3) Gravel or stone dust may be appropriate, but must be contained.
- 4) Stamped concrete and stamped asphalt are not appropriate paving materials.
- 5) Limit asphalt use to driveways and parking areas.
- 6) Place driveways through the front yard only when no rear access to parking is available.
- 7) Do not demolish historic structures to provide areas for parking.
- 8) Add separate pedestrian pathways within larger parking lots, and provide crosswalks at vehicular lanes within a site.

#### F. Parking Areas and Lots

- 1) If new parking areas are necessary, construct them so that they reinforce the street wall of buildings and the grid system of rectangular blocks in commercial areas.
- 2) Locate parking lots behind buildings.
- 3) Screen parking lots from streets, sidewalks, and neighboring sites through the use of walls, trees, and plantings of a height and type appropriate to reduce the visual impact year-round.
- 4) Avoid creating parking areas in the front yards of historic building sites.
- 5) Avoid excessive curb cuts to gain entry to parking areas.
- 6) Avoid large expanses of asphalt.
- 7) On large lots, provide interior plantings and pedestrian walkways.
- 8) Provide screening from adjacent land uses as needed.
- 9) Install adequate lighting in parking areas to provide security in evening hours.
- 10) Select lighting fixtures that are appropriate to a historic setting.

#### H. Utilities and Other Site Appurtenances

1. Plan the location of overhead wires, utility poles and meters, electrical panels, antennae, trash containers, and exterior mechanical units where they are least likely to detract from the character of the site.
2. Screen utilities and other site elements with fences, walls, or plantings.
3. Encourage the installation of utility services underground.
4. Antennae and communication dishes should be placed in inconspicuous rooftop locations, not in a front yard.

5. Screen all rooftop mechanical equipment with a wall of material harmonious with the building or structure.

### **Chapter III – New Construction and Additions**

Link: [Chapter 3 New Construction and Additions](#)

#### A. Introduction

...

#### 3. Building Types within the Historic Districts

When designing new buildings in the historic districts, one needs to recognize that while there is an overall distinctive district character, there is, nevertheless, a great variety of historic building types, styles, and scales throughout the districts and sub-areas that are described in Chapter 1: Introduction. Likewise, there are several types of new construction that might be constructed within the districts the design parameters of these new buildings will differ depending on the following types:

##### b. Residential Infill

These buildings are new dwellings that are constructed on the occasional vacant lot within a block of existing historic houses. Setback, spacing, and general massing of the new dwelling are the most important criteria that should relate to the existing historic structures, along with residential roof and porch forms.

#### B. Setback

- 1) Construct new commercial buildings with a minimal or no setback in order to reinforce the traditional street wall.
- 2) Use a minimal setback if the desire is to create a strong street wall or setback consistent with the surrounding area.
- 3) Modify setback as necessary for sub-areas that do not have well-defined street walls.
- 4) Avoid deep setbacks or open corner plazas on corner buildings in the downtown in order to maintain the traditional grid of the commercial district.
- 5) In the West Main Street corridor, construct new buildings with a minimal (up to 15 feet according to the zoning ordinance) or no setback in order to reinforce the street wall. If the site adjoins historic buildings, consider a setback consistent with these buildings.
- 6) On corners of the West Main Street corridor, avoid deep setbacks or open corner plazas unless the design contributes to the pedestrian experience or improves the transition to an adjacent residential area.
- 7) New buildings, particularly in the West Main Street corridor, should relate to any neighborhoods adjoining them. Buffer areas should be considered to include any screening and landscaping requirements of the zoning ordinance.
- 8) At transitional sites between two distinctive areas of setback, for instance between new commercial and historic commercial, consider using setbacks in the new construction that reinforce and relate to setbacks of the historic buildings.
- 9) For new governmental or institutional buildings, either reinforce the street wall through a minimal setback, or use a deep setback within a landscaped area to emphasize the civic function of the structure.
- 10) **Keep residential setbacks within 20 percent of the setbacks of a majority of neighborhood dwellings.**

**Staff Comment:** Average front setback for nearby structures is approximately 33-ft, ranging between 0-ft and 95-ft. Proposed building front setback is approximately 15 f-ft.



C. Spacing

- 1) Maintain existing consistency of spacing in the area. New residences should be spaced within 20 percent of the average spacing between houses on the block.

**Staff Comment:** Average side spacing for nearby structures is approximately 31 feet, ranging between 5 and 93 feet. Proposed building spacing is approximately 27 feet from 1215 Wertland Street and 10 feet from the existing house.



- 2) Commercial and office buildings in the areas that have a well-defined street wall should have minimal spacing between them.
- 3) In areas that do not have consistent spacing, consider limiting or creating a more uniform spacing in order to establish an overall rhythm.
- 4) Multi-lot buildings should be designed using techniques to incorporate and respect the existing spacing on a residential street.

D. Massing and Footprint

- 1) New commercial infill buildings' footprints will be limited by the size of the existing lot in the downtown or along the West Main Street corridor. Their massing in most cases should be simple rectangles like neighboring buildings.
- 2) New infill construction in residential sub-areas should relate in footprint and massing to the majority of surrounding historic dwellings.

**Staff Comment:** Average footprint for nearby structures is approximately 4,000 square feet, ranging from 1,500 square feet to 14,000 square feet. Proposed building footprint will be approximately 5,600 square feet.

#### E. Height and Width

- 1) Respect the directional expression of the majority of surrounding buildings. In commercial areas, respect the expression of any adjacent historic buildings, which generally will have a more vertical expression.
- 2) Attempt to keep the height and width of new buildings within a maximum of 200 percent of the prevailing height and width in the surrounding sub-area.

**Staff Comment:**

*Height.* Prevailing height of nearby structures is three stories, ranging from two to five stories. The recommended max height of the new building would be six stories. Proposed building will be four stories.

*Width.* Average building width nearby structures is approximately 45 feet, ranging between approximately 30 feet and 72 feet. Proposed building will be approximately 40 feet wide.

- 3) In commercial areas at street front, the height should be within 130 percent of the prevailing average of both sides of the block. Along West Main Street, heights should relate to any adjacent contributing buildings. Additional stories should be stepped back so that the additional height is not readily visible from the street.
- 4) When the primary façade of a new building in a commercial area, such as downtown, West Main Street, or the Corner, is wider than the surrounding historic buildings or the traditional lot size, consider modulating it with bays or varying planes.
- 5) Reinforce the human scale of the historic districts by including elements such as porches, entrances, storefronts, and decorative features depending on the character of the particular sub-area.
- 6) In the West Main Street corridor, regardless of surrounding buildings, new construction should use elements at the street level, such as cornices, entrances, and display windows, to reinforce the human scale.

#### F. Scale

- 1) Provide features on new construction that reinforce the scale and character of the surrounding area, whether human or monumental. Include elements such as storefronts, vertical and horizontal divisions, upper story windows, and decorative features.
- 2) As an exception, new institutional or governmental buildings may be more appropriate on a monumental scale depending on their function and their site conditions.

#### G. Roof

- 1) Roof Forms and Pitches
  - a. The roof design of new downtown or West Main Street commercial infill buildings generally should be flat or sloped behind a parapet wall.
  - b. Neighborhood transitional buildings should use roof forms that relate to the neighboring residential forms instead of the flat or sloping commercial form.
  - c. Institutional buildings that are freestanding may have a gable or hipped roof with variations.

- d. Large-scale, multi-lot buildings should have a varied roof line to break up the mass of the design using gable and/or hipped forms.
  - e. Shallow pitched roofs and flat roofs may be appropriate in historic residential areas on a contemporary designed building.
  - f. Do not use mansard-type roofs on commercial buildings; they were not used historically in Charlottesville’s downtown area, nor are they appropriate on West Main Street.
- 2) Roof Materials: Common roof materials in the historic districts include metal, slate, and composition shingles.
- a. For new construction in the historic districts, use traditional roofing materials such as standing-seam metal or slate.
  - b. In some cases, shingles that mimic the appearance of slate may be acceptable.
  - c. Pre-painted standing-seam metal roof material is permitted, but commercial-looking ridge caps or ridge vents are not appropriate on residential structures.
  - d. Avoid using thick wood cedar shakes if using wood shingles; instead, use more historically appropriate wood shingles that are thinner and have a smoother finish.
  - e. If using composition asphalt shingles, do not use light colors. Consider using neutral-colored or darker, plain or textured-type shingles.
  - f. The width of the pan and the seam height on a standing-seam metal roof should be consistent with the size of pan and seam height usually found on a building of a similar period.
- 3) Rooftop Screening
- a. If roof-mounted mechanical equipment is used, it should be screened from public view on all sides.
  - b. The screening material and design should be consistent with the design, textures, materials, and colors of the building.
  - c. The screening should not appear as an afterthought or addition the building.

#### H. Orientation

- 1) New commercial construction should orient its façade in the same direction as adjacent historic buildings, that is, to the street.
- 2) Front elevations oriented to side streets or to the interior of lots should be discouraged.

#### I. Windows and Doors

- 1) The rhythm, patterns, and ratio of solids (walls) and voids (windows and doors) of new buildings should relate to and be compatible with adjacent historic facades.
  - a. The majority of existing buildings in Charlottesville’s historic districts have a higher proportion of wall area than void area except at the storefront level.
  - b. In the West Main Street corridor in particular, new buildings should reinforce this traditional proportion.
- 2) The size and proportion, or the ratio of width to height, of window and door openings on new buildings’ primary facades should be similar and compatible with those on surrounding historic facades.
  - a. The proportions of the upper floor windows of most of Charlottesville’s historic buildings are more vertical than horizontal.
  - b. Glass storefronts would generally have more horizontal proportions than upper floor openings.

- 3) Traditionally designed openings generally are recessed on masonry buildings and have a raised surround on frame buildings. New construction should follow these methods in the historic districts as opposed to designing openings that are flush with the rest of the wall.
- 4) Many entrances of Charlottesville's historic buildings have special features such as transoms, sidelights, and decorative elements framing the openings. Consideration should be given to incorporating such elements in new construction.
- 5) Darkly tinted mirrored glass is not an appropriate material for windows in new buildings within the historic districts.
- 6) If small-paned windows are used, they should have true divided lights or simulated divided lights with permanently affixed interior and exterior muntin bars and integral spacer bars between the panes of glass.
- 7) Avoid designing false windows in new construction.
- 8) Appropriate material for new windows depends upon the context of the building within a historic district, and the design of the proposed building. Sustainable materials such as wood, aluminum-clad wood, solid fiberglass, and metal windows are preferred for new construction. Vinyl windows are discouraged.
- 9) Glass shall be clear. Opaque spandrel glass or translucent glass may be approved by the BAR for specific applications.

#### J. Porches

- 1) Porches and other semi-public spaces are important in establishing layers or zones of intermediate spaces within the streetscape.

#### L. Foundation and Cornice

- 1) Distinguish the foundation from the rest of the structure through the use of different materials, patterns, or textures.
- 2) Respect the height, contrast of materials, and textures of foundations on surrounding historic buildings.
- 3) If used, cornices should be in proportion to the rest of the building.
- 4) Wood or metal cornices are preferred. The use of fypon may be appropriate where the location is not immediately adjacent to pedestrians.

#### M. Materials and Textures

- 1) The selection of materials and textures for a new building should be compatible with and complementary to neighboring buildings.
- 2) In order to strengthen the traditional image of the residential areas of the historic districts, brick, stucco, and wood siding are the most appropriate materials for new buildings.
- 3) In commercial/office areas, brick is generally the most appropriate material for new structures. "Thin set" brick is not permitted. Stone is more commonly used for site walls than buildings.
- 4) Large-scale, multi-lot buildings, whose primary facades have been divided into different bays and planes to relate to existing neighboring buildings, can have varied materials, shades, and textures.
- 5) Synthetic siding and trim, including, vinyl and aluminum, are not historic cladding materials in the historic districts, and their use should be avoided.
- 6) Cementitious siding, such as HardiPlank boards and panels, are appropriate.
- 7) Concrete or metal panels may be appropriate.
- 8) Metal storefronts in clear or bronze are appropriate.

- 9) The use of Exterior Insulation and Finish Systems (EIFS) is discouraged but may be approved on items such as gables where it cannot be seen or damaged. It requires careful design of the location of control joints.
- 10) The use of fiberglass-reinforced plastic is discouraged. If used, it must be painted.
- 11) All exterior trim woodwork, decking and flooring must be painted, or may be stained solid if not visible from public right-of-way.

#### N. Paint [Color palette]

- 1) The selection and use of colors for a new building should be coordinated and compatible with adjacent buildings, not intrusive.
- 2) In Charlottesville's historic districts, various traditional shades of brick red, white, yellow, tan, green, or gray are appropriate. For more information on colors traditionally used on historic structures and the placement of color on a building, see Chapter 4: Rehabilitation.
- 3) Do not paint unpainted masonry surfaces.
- 4) It is proper to paint individual details different colors.
- 5) More lively color schemes may be appropriate in certain sub-areas dependent on the context of the sub-areas and the design of the building.

#### O. Details and Decoration

- 1) Building detail and ornamentation should be consistent with and related to the architecture of the surrounding context and district.
- 2) The mass of larger buildings may be reduced using articulated design details.
- 3) Pedestrian scale may be reinforced with details.

#### Checklist from section P. Additions

Many of the smaller commercial and other business buildings may be enlarged as development pressure increases in downtown Charlottesville and along West Main Street. These existing structures may be increased in size by constructing new additions on the rear or side or in some cases by carefully adding on extra levels above the current roof. The design of new additions on all elevations that are prominently visible should follow the guidelines for new construction as described earlier in this section. Several other considerations that are specific to new additions in the historic districts are listed below:

- 1) Function and Size
  - a. Attempt to accommodate needed functions within the existing structure without building an addition.
  - b. Limit the size of the addition so that it does not visually overpower the existing building.
- 2) Location
  - a. Attempt to locate the addition on rear or side elevations that are not visible from the street.
  - b. If additional floors are constructed on top of a building, set the addition back from the main façade so that its visual impact is minimized.
  - c. If the addition is located on a primary elevation facing the street or if a rear addition faces a street, parking area, or an important pedestrian route, the façade of the addition should be treated under the new construction guidelines.
- 3) Design
  - a. New additions should not destroy historic materials that characterize the property.
  - b. The new work should be differentiated from the old and should be compatible with the massing, size, scale, and architectural features to protect the historic integrity of the property and its environment.



- 4) Replication of Style
  - a. A new addition should not be an exact copy of the design of the existing historic building. The design of new additions can be compatible with and respectful of existing buildings without being a mimicry of their original design.
  - b. If the new addition appears to be part of the existing building, the integrity of the original historic design is compromised and the viewer is confused over what is historic and what is new.
- 5) Materials and Features
  - a. Use materials, windows, doors, architectural detailing, roofs, and colors that are compatible with historic buildings in the district.
- 6) Attachment to Existing Building
  - a. Wherever possible, new additions or alterations to existing buildings should be done in such a manner that, if such additions or alterations were to be removed in the future, the essential form and integrity of the buildings would be unimpaired.
  - b. The new design should not use the same wall plane, roof line, or cornice line of the existing structure.

#### **Chapter IV – *Rehabilitation***

Link: [Chapter 4 Rehabilitation](#)

As applicable to any exterior alterations to the historic house and site.

**Appendix**

Incorrect rendering (sheet 18 of submittal;)



PROPOSED PERSPECTIVE ON WERTLAND ST.

18

Correct rendering



Canopy at garage entrance



Stain for exposed wood ceiling

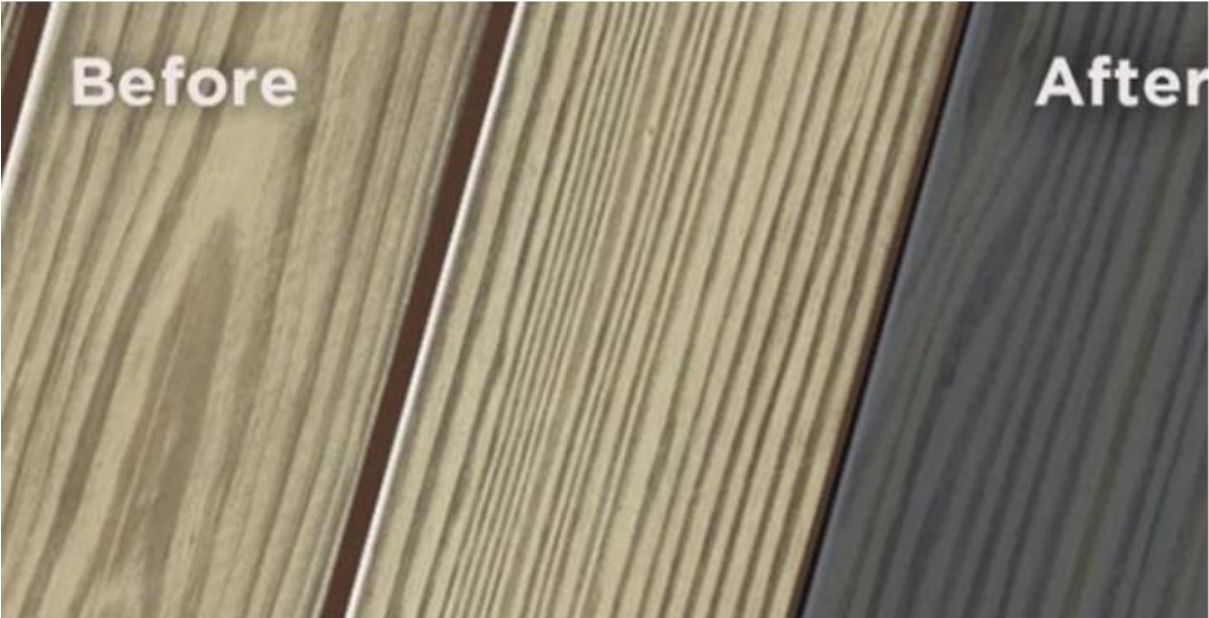

Rendering: exposed wood ceiling

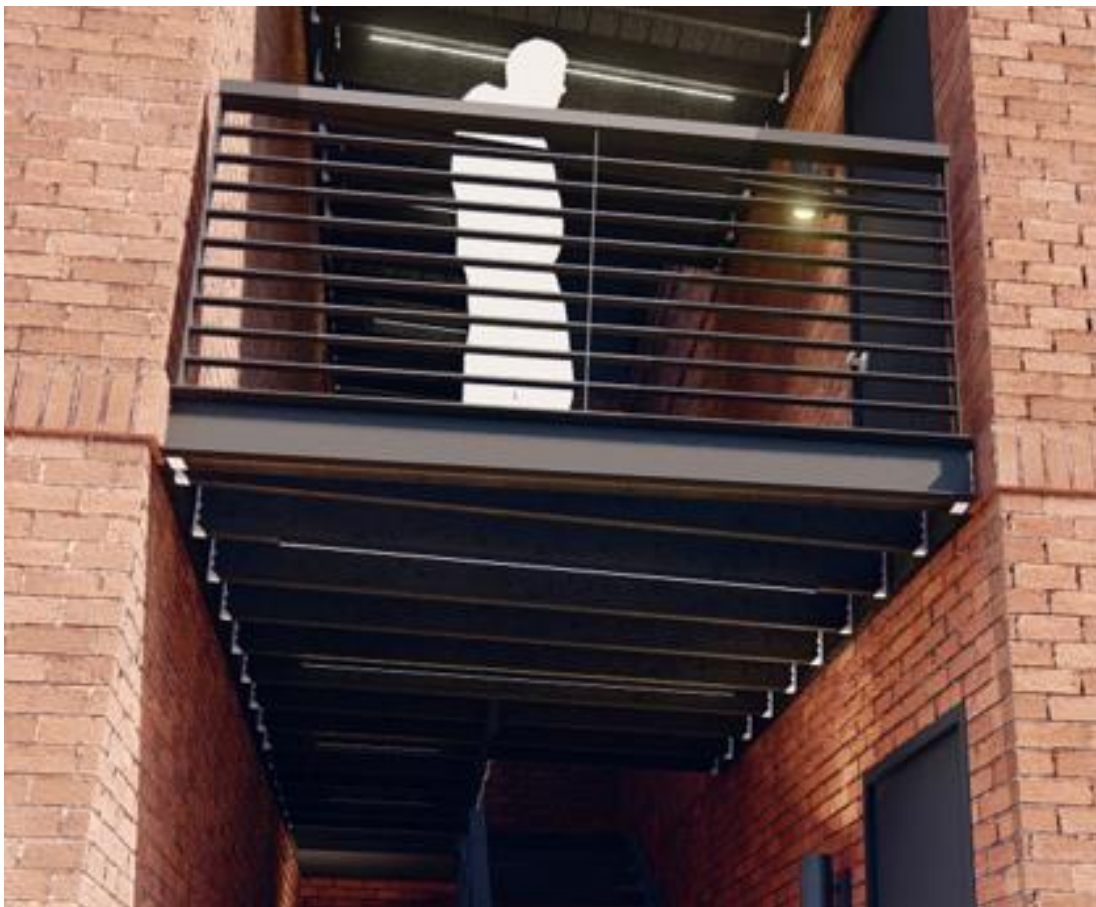
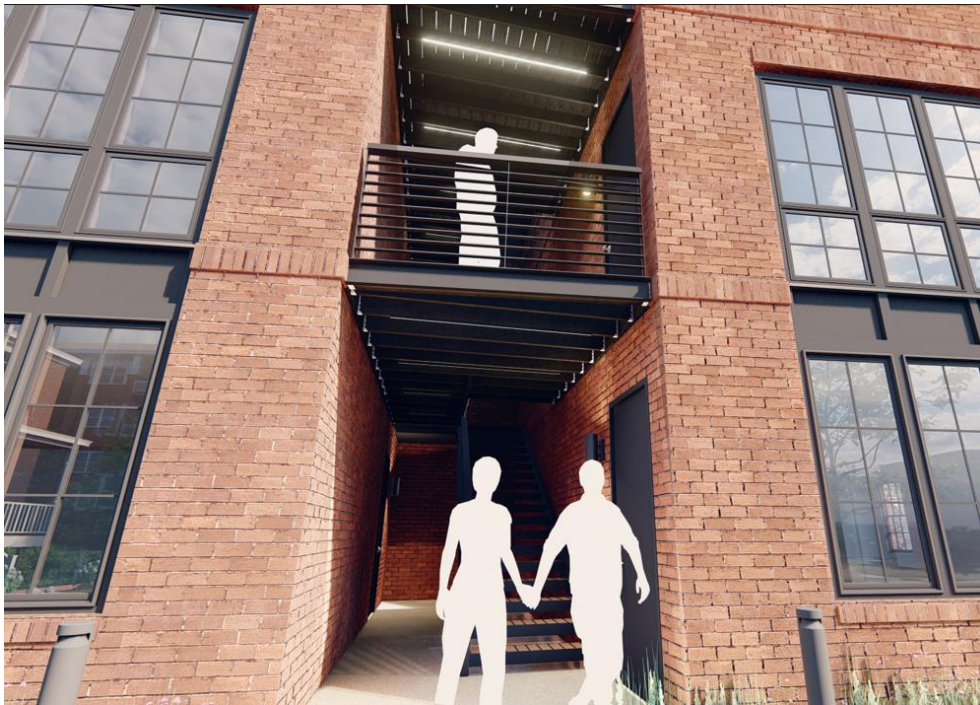

Misc. maps and information

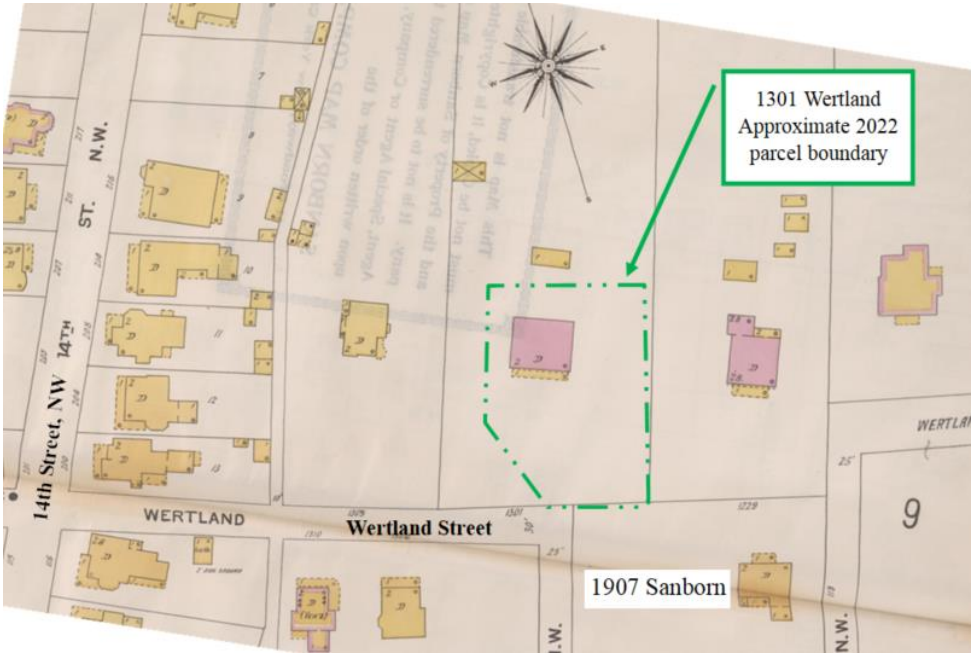

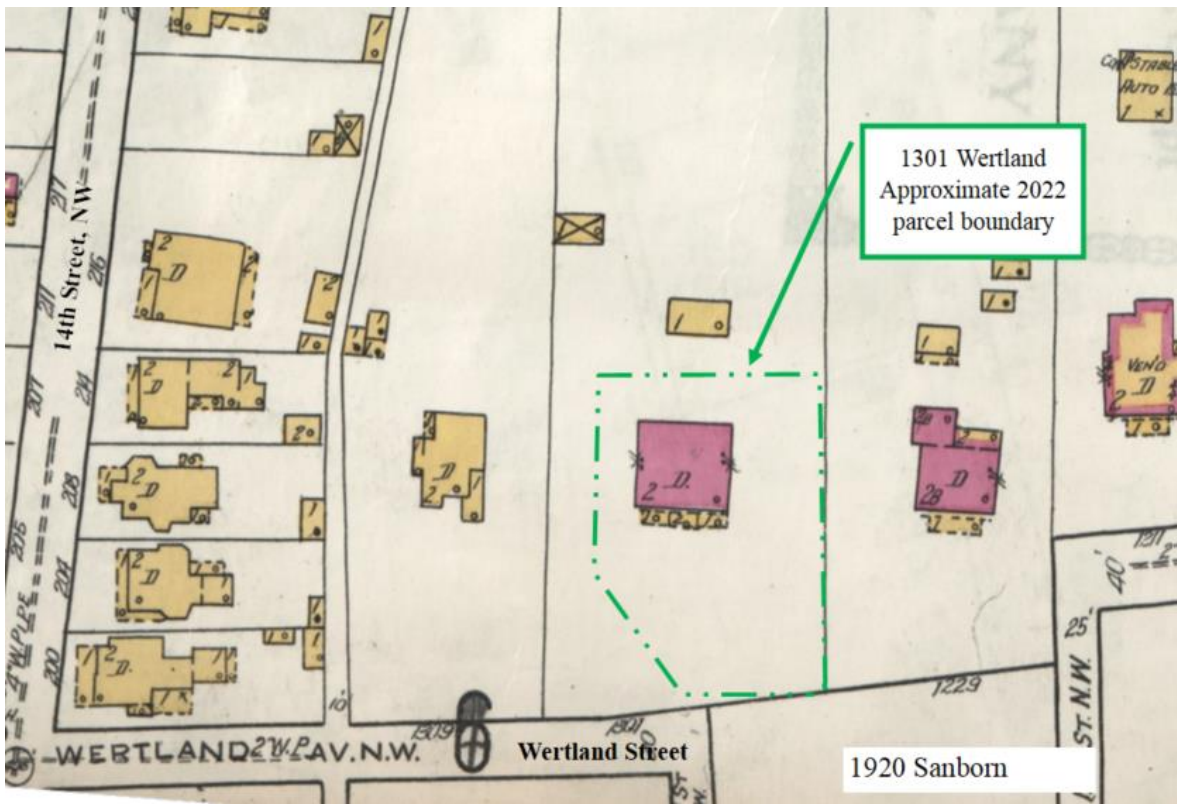

**Wm. Wertenbaker Property**

Approx. parcel lines, based on historical survey notes

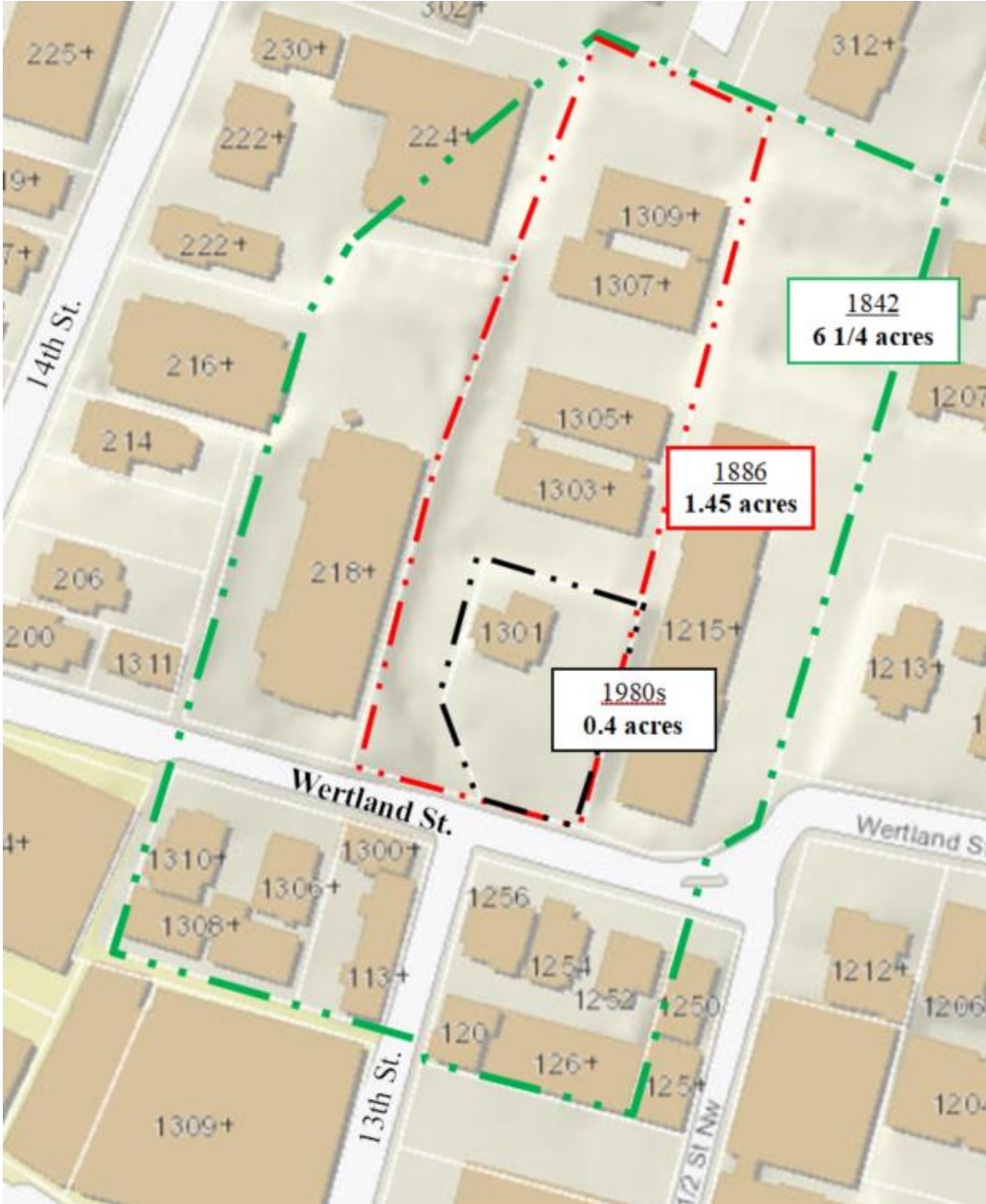

(prepared by BAR staff 01/04/2023)





(prepared by BAR staff 01/04/2023)



February 2022



March 2022

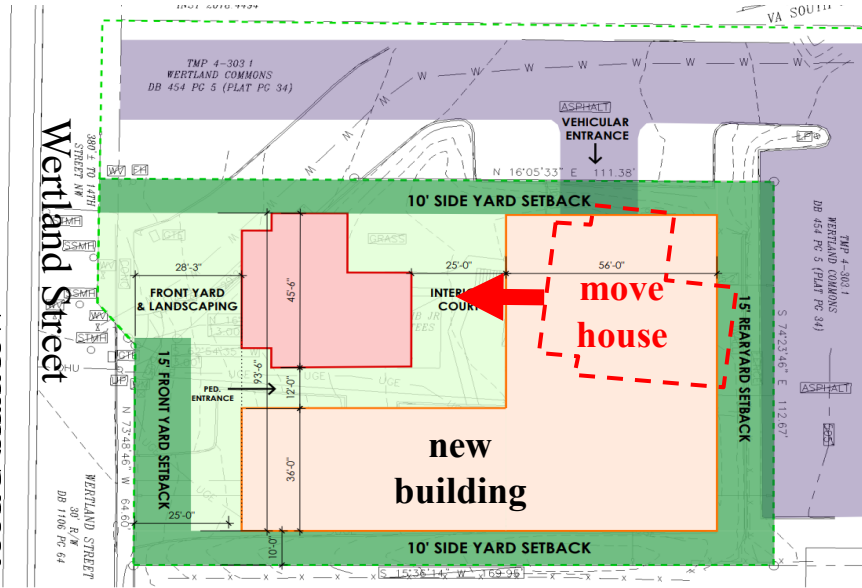

September 2022



October 2022

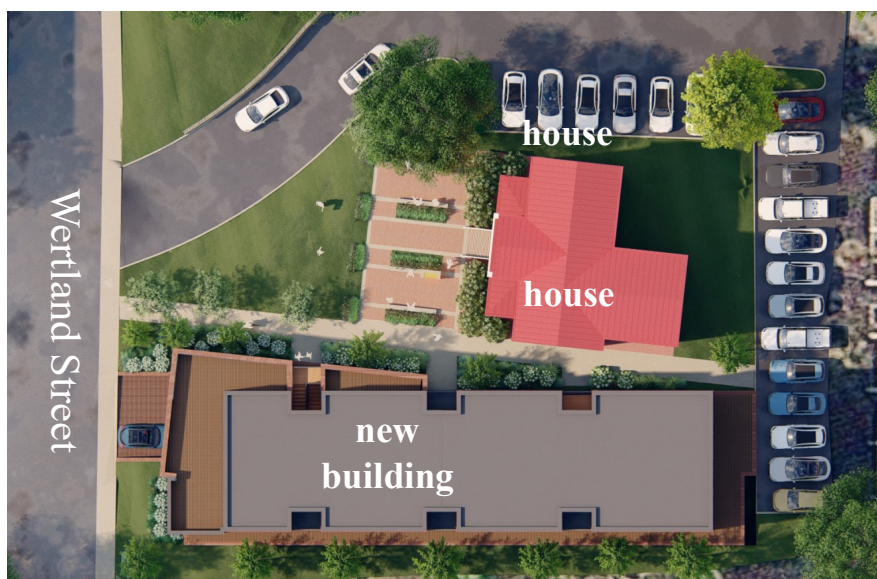

January 2023



1301 WERTLAND ST.  
PARCEL 040303000  
BAR SUBMISSION

PRESENTED BY



**DESIGN**  
DEVELOP

12 | 27 | 2022



1 | COVER  
3 | TABLE OF CONTENTS  
4-5 | PROJECT NARRATIVE  
6 | PROXIMITY MAP  
7 | CONTEXT IMAGES  
8-9 | MASSING AND SITE DIAGRAMS  
10-11 | MEETING ACDC GUIDLINES  
12-19 | RENDERINGS  
20 | STREET SECTION  
21-24 | RENDERED ELEVATIONS  
25-29 | PLANTING SELECTIONS  
30-33 | EXTERIOR SITE & EGRESS LIGHTING  
34-35 | MATERIAL SELECTIONS  
36 | WINDOW & DOOR SELECTIONS  
37 | GUARDRAIL DETAILS  
38 | HVAC UNIT LOCATION & SCREENING  
39-41 | *APPENDIX ONE: ARCHITECTURAL ELEVATIONS*

A. INTRODUCTION: (PG 6) OFTEN NEW COMMERCIAL, OFFICE, OR MULTI-USE BUILDINGS WILL BE CONSTRUCTED ON SITES MUCH LARGER THAN THE TRADITIONALLY SIZED LOTS 25 TO 40 FEET WIDE. MANY SITES FOR SUCH STRUCTURES ARE LOCATED ON WEST MAIN STREET AND IN THE 14TH AND 15TH STREET AREA OF THE VENABLE NEIGHBORHOOD. THESE ASSEMBLED PARCELS CAN TRANSLATE INTO NEW STRUCTURES WHOSE SCALE AND MASS MAY OVERWHELM NEIGHBORING EXISTING STRUCTURES. **THEREFORE, WHILE THIS BUILDING TYPE MAY NEED TO RESPOND TO THE VARIOUS BUILDING CONDITIONS OF THE SITE, IT ALSO SHOULD EMPLOY DESIGN TECHNIQUES TO REDUCE ITS VISUAL PRESENCE. THESE COULD INCLUDE VARYING FACADE WALL PLANES, DIFFERING MATERIALS, STEPPED-BACK UPPER LEVELS, AND IRREGULAR MASSING.**



... TAKE CUES FROM THE ADJACENT CONTEXTUAL STRUCTURES ALONG THE WERTLAND STREET ARCHITECTURAL DESIGN CONTROL DISTRICT. REDUCE THE VISUAL PRESENCE BY REDUCING THE MASS INTO FOUR DISTINCT VOLUMES. PROVIDE A GENEROUS STEPPED-BACK THIRD STORY. PROVIDE IRREGULAR MASSING THAT RESPONDS TO THE UNIQUE CONDITIONS OF THE HISTORIC WERTENBAKER HOUSE (5 DEGREE SKEW TO THE STREET).

B. SETBACK: (PG 7) CONSTRUCT NEW COMMERCIAL BUILDINGS WITH A MINIMAL OR NO SETBACK IN ORDER TO REINFORCE THE TRADITIONAL STREET WALL. USE A MINIMAL SETBACK IF THE DESIRE IS TO CREATE A STRONG STREET WALL OR SETBACK CONSISTENT WITH THE SURROUNDING AREA. **KEEP RESIDENTIAL SETBACKS WITHIN 20 PERCENT OF THE SETBACKS OF A MAJORITY OF NEIGHBORHOOD DWELLINGS. AT TRANSITIONAL SITES BETWEEN TWO DISTINCTIVE AREAS OF SETBACK, FOR INSTANCE BETWEEN NEW COMMERCIAL AND HISTORIC COMMERCIAL, CONSIDER USING SETBACKS IN THE NEW CONSTRUCTION THAT REINFORCE AND RELATE TO SETBACKS OF THE HISTORIC BUILDINGS.**



... REACT AND RESPOND TO ADJACENT STRUCTURES, PARTICULARLY ALONG THE WESTERN SIDE OF WERTLAND STREET, AFTER THE JOG IN THE ROAD AT 12 1/2 STREET NW. THE JOG IN WERTLAND STREET IS UNFORTUNATE, BUT HAS BECOME THE RECOGNIZABLE NORMATIVE CONDITION, WHILE SEVERING THE DISTRICT INTO TWO DISTINCT STREETWALL CONDITIONS. WEST OF 12 1/2 STREET NW, THE DISTRICT UTILIZES VERY TIGHT, LIMITED FROM SETBACKS, EXCEPT FOR THE HISTORIC WERTENBAKER HOUSE (AN IMPORTANT REASON TO RETAIN THE ORIGINAL LOCATION OF THE HOUSE).

C. SPACING: (PG 8) **MAINTAIN EXISTING CONSISTENCY OF SPACING IN THE AREA.** NEW RESIDENCES SHOULD BE SPACED WITHIN 20 PERCENT OF THE AVERAGE SPACING BETWEEN HOUSES ON THE BLOCK. IN AREAS THAT DO NOT HAVE CONSISTENT SPACING, CONSIDER LIMITING OR CREATING A MORE UNIFORM SPACING IN ORDER TO ESTABLISH AN OVERALL RHYTHM.



... REINFORCE THE ESTABLISHED AND EXISTING SPACING BETWEEN BUILDINGS FOUND ON THE BLOCK. EVEN IN THE EASTERN PORTION OF THE WERTLAND STREET ADCD, WHERE GENEROUS FRONT YARDS ARE PROVIDED, SIDE YARDS ARE VERY LIMITED. AN ANALYSIS OF SPACING CAN BE FOUND LATER IN THIS BOOKLET.

D. MASSING AND FOOTPRINT: (PG 9) NEIGHBORHOOD TRANSITIONAL BUILDINGS SHOULD HAVE SMALL BUILDING FOOTPRINTS SIMILAR TO NEARBY DWELLINGS.

1. IF THE FOOTPRINT IS LARGER, THEIR MASSING SHOULD BE REDUCED TO RELATE TO THE SMALLER-SCALED FORMS OF RESIDENTIAL STRUCTURES.
2. TECHNIQUES TO REDUCE MASSING COULD INCLUDE **VARYING THE SURFACE LANES OF THE BUILDINGS, STEPPING BACK THE BUILDINGS AS THE STRUCTURE INCREASES IN HEIGHT, AND BREAKING UP THE ROOF LINE WITH DIFFERENT ELEMENTS TO CREATE SMALLER COMPOSITIONS.**



... REDUCE LARGER MASSING TO SMALLER-SCALED FORMS BY BREAKING UP THE ROOF LINE, VARYING THE SURFACE OF THE BUILDING, AND STEPPING BACK THE BUILDING AT THE STREET LINE.

E. HEIGHT AND WIDTH: (PG 10) RESPECT THE DIRECTIONAL EXPRESSION OF THE MAJORITY OF SURROUNDING BUILDINGS. ATTEMPT TO KEEP THE HEIGHT AND WIDTH OF NEW BUILDINGS WITHIN A MAXIMUM OF 200 PERCENT OF THE PREVAILING HEIGHT AND WIDTH IN THE SURROUNDING SUB-AREA. **REINFORCE THE HUMAN SCALE OF THE HISTORIC DISTRICTS BY INCLUDING ELEMENTS SUCH AS PORCHES, ENTRANCES, STOREFRONTS, AND DECORATIVE FEATURES DEPENDING ON THE CHARACTER OF THE PARTICULAR SUB-AREA.**



BY ALLOWING STAIRS TOWERS AND BALCONIES TO CREATE VISUAL SLOTS IN THE MASS, THE PROPOSED STRUCTURE READS AS A SERIES OF (4) TWO-STORY, 30' WIDE RESIDENTIALLY-SCALED MASSES, SIMILAR TO WATER STREET EXTENDED OR BRICK TOWN HOMES FOUND THROUGHOUT THE AREA. THE ROTATED BRICK MASS AND FOOTPRINT ALSO REITERATE THE SKEW OF THE HISTORIC HOUSE TO WERTLAND STREET.

... RESPECT THE DIRECTIONAL EXPRESSION OF THE SURROUNDING BUILDINGS BY ESTABLISHING A DIRECTIONAL RELATIONSHIP BETWEEN THE OLD AND NEW CONSTRUCTION.

THE TWO STORY BRICK MASS OF THE PROPOSED STRUCTURE ALIGNS WITH THE HEIGHT OF THE CORNICE LINE OF THE EXISTING HOUSE. THE WIDTH OF THE BRICK MASSES DIRECTLY RELATE TO THE RESIDENTIAL SCALE FOUND ALONG WERTLAND STREET. THE PROJECT REINFORCES THE HUMAN SCALE BY PROVIDING BALCONIES AND PORCHES. LANDSCAPING AROUND THE BUILDING MINIMIZES THE VISUAL IMPACT OF THE HEIGHT FROM THE STREET.

F. SCALE: (PG 11) IN CHARLOTTESVILLE, THERE IS A VARIETY OF SCALE. **REINFORCE THE SCALE AND CHARACTER OF THE SURROUNDING AREA, WHETHER HUMAN OR MONUMENTAL.**



... ACKNOWLEDGE THAT THIS DISTRICT HAS VARYING SCALES, ARCHITECTURAL STYLES, USES, AND TECHNIQUES IN DEALING WITH SCALE. REINFORCE THIS VARIATION BY PROVIDING A THOUGHTFULLY COMPOSED AND COHESIVE EXTERIOR THAT DIRECTLY REFERENCES THE SCALE OF THE ADJACENT HISTORIC STRUCTURE. INTRODUCE DETAILING ELEMENTS TO REINFORCE THE HUMAN SCALE.

**G. ROOF:** (PG 12) **LARGE-SCALE, MULTI-LOT BUILDINGS SHOULD HAVE A VARIED ROOF LINE TO BREAK UP THE MASS OF THE DESIGN USING GABLE AND/OR HIPPED FORMS.** SHALLOW PITCHED ROOFS AND FLAT ROOFS MAY BE APPROPRIATE IN HISTORIC RESIDENTIAL AREAS ON A CONTEMPORARY DESIGNED BUILDING.



...PROVIDE A VARIED ROOF LINE TO BREAK UP THE MASSING. UTILIZE THE VOIDS CREATED BY STAIRS, BALCONIES, AND BUILDING FORMS TO PROVIDE A VARIED ROOF LINE. UTILIZE PARAPETS IN LIEU OF LARGE OVERHANGS TO SHIELD MECHANICAL EQUIPMENT WHILE REDUCING THE VISUAL IMPACT OF THE ROOF LINE.

**H. ORIENTATION:** (PG 14) **NEW COMMERCIAL CONSTRUCTION SHOULD ORIENT ITS FAÇADE IN THE SAME DIRECTION AS ADJACENT HISTORIC BUILDINGS, THAT IS, TO THE STREET.**



...THE PROPOSED PROJECT ADDRESSES THE STREET WITH A TWO-STORY CORNER TOWER ELEMENT ON THE SOUTHEASTERN CORNER THAT SERVES TO ENGAGE THE PEDESTRIAN WHILE BREAKING DOWN THE MASS OF THE FRONT FACADE. THIS MASS ALSO RESOLVES THE SKEW OF THE BRICK BASE BUILDING. THE PROJECT ALSO HAS THE UNIQUE OPPORTUNITY TO "FACE" THE WERTENBAKER HOUSE AND THE FRONT YARD. BY ADDING BALCONIES AND LARGE GLAZING BAYS TOWARDS THE HISTORIC HOUSE, THE PROPOSED PROJECT AIMS TO ORIENT ITSELF COMPOSITIONALLY IN TWO DIRECTIONS.

**I. WINDOWS AND DOORS:** (PG 15) **THE RHYTHM, PATTERNS, AND RATIO OF SOLIDS (WALLS) AND VOIDS (WINDOWS AND DOORS) OF NEW BUILDINGS SHOULD RELATE TO AND BE COMPATIBLE WITH ADJACENT HISTORIC FACADES.** THE SIZE AND PROPORTION, OR THE RATIO OF WIDTH TO HEIGHT, OF WINDOW AND DOOR OPENINGS ON NEW BUILDINGS' PRIMARY FACADES SHOULD BE SIMILAR AND COMPATIBLE WITH THOSE ON SURROUNDING HISTORIC FACADES.



...PROVIDE APPROPRIATELY PROPORTIONED WINDOWS THAT RELATE TO AND ARE COMPATIBLE WITH ADJACENT HISTORIC FACADES. RESIDENTIAL SCALED, PUNCHED OPENINGS ARE PROPOSED IN A MORE TRADITIONAL AND RATIONAL ORDER ARRANGEMENT. ON FACADES THAT FACE WERTLAND STREET AND THE WERTENBAKER HOUSE, APPROPRIATELY PROPORTIONED GLAZING BAYS HAVE BEEN INTRODUCED TO BREAK UP THE MASS AND ENGAGE THE PEDESTRIAN.

**K. STREET-LEVEL DESIGN:** (PG 17) **STREET LEVEL FACADES OF ALL BUILDING TYPES, WHETHER COMMERCIAL, OFFICE, OR INSTITUTIONAL, SHOULD NOT HAVE BLANK WALLS;** THEY SHOULD PROVIDE VISUAL INTEREST TO THE PASSING PEDESTRIAN. NEIGHBORHOOD TRANSITIONAL BUILDINGS IN GENERAL SHOULD NOT HAVE TRANSPARENT FIRST FLOORS, AND THE DESIGN AND SIZE OF THEIR FAÇADE OPENINGS SHOULD RELATE MORE TO NEIGHBORING RESIDENTIAL STRUCTURES.



... ELIMINATE BLANK WALLS THROUGH CHANGE IN MATERIALS, BALCONIES, PORCHES, CIRCULATION CORE ELEMENTS, AND APPROPRIATE AMOUNTS OF GLAZING. CREATE A DISTINCT TWO-STORY MASS TO FACE THE STREET BY REFERENCING THE CORNICE LINE OF THE WERTENBAKER HOUSE. PROVIDE A THIRD STORY THAT RECEDES FROM THE STREETWALL / BUILDING FACADES. UTILIZE PORCHES AND ENTRANCES TO BREAK DOWN BLANK WALLS.

**L. FOUNDATION & CORNICE:** (PG 18) FACADES GENERALLY HAVE A THREE-PART COMPOSITION: A FOUNDATION OR BASE THAT RESPONDS AT THE PEDESTRIAN OR STREET, THE MIDDLE SECTION, AND THE CAP OR CORNICE THAT TERMINATES THE MASS AND ADDRESSES HOW THE BUILDING MEETS THE SKY



...PROPOSE A BRICK FOUNDATION AND BRICK BASE. ABOVE THE BRICK CORNICE LINE (AT THE SILL OF THE THIRD FLOOR WINDOWS) TRANSITION TO A THIRD STORY THAT STEPS BACK FROM WERTLAND STREET AND REMAINS ORTHOGONAL TO THE STREET (FURTHER EMPHASIZING THE SKEW OF THE BRICK MASS BELOW). LEGIBLE VOLUMES TERMINATE IN A PARAPET WALL AND COPING CAP TO VISUALLY SIMPLIFY THE FORM.

**M. MATERIALS & TEXTURES:** (PG 19) **THE SELECTION OF MATERIALS AND TEXTURES FOR A NEW BUILDING SHOULD BE COMPATIBLE WITH AND COMPLEMENTARY TO NEIGHBORING BUILDINGS.** IN ORDER TO STRENGTHEN THE TRADITIONAL IMAGE OF THE RESIDENTIAL AREAS OF THE HISTORIC DISTRICTS, BRICK, STUCCO, AND WOOD SIDING ARE THE MOST APPROPRIATE MATERIALS FOR NEW BUILDINGS. LARGE-SCALE, MULTI-LOT BUILDINGS, WHOSE PRIMARY FACADES HAVE BEEN DIVIDED INTO DIFFERENT BAYS AND PLANES TO RELATE TO EXISTING NEIGHBORING BUILDINGS, CAN HAVE VARIED MATERIALS, SHADES, AND TEXTURES.



... SELECT HIGH-QUALITY, LOW MAINTENANCE MATERIALS THAT ARE IN KEEPING WITH ADJACENT ESTABLISHED MATERIAL CHOICES. THE PROPOSED MATERIALS ARE BRICK AND FIBER-CEMENT PANELIZED SIDING (I.E. HARDIEPANEL). KEY AREAS WILL UTILIZE METAL PANEL TRIM.

**N. PAINT:** (PG 20) THE SELECTION AND USE OF COLORS FOR A NEW BUILDING SHOULD BE COORDINATED AND COMPATIBLE WITH ADJACENT BUILDINGS, NOT INTRUSIVE.



... AVOID BRIGHTLY COLORED OR INTRUSIVE PAINT COLORS

**O. DETAILS AND DECORATIONS:** (PG 21) **MORE SUCCESSFUL NEW BUILDINGS MAY TAKE THEIR CUES FROM HISTORIC IMAGES AND REINTRODUCE AND REINTERPRET DESIGNS OF TRADITIONAL DECORATIVE ELEMENTS** OR MAY HAVE A MODERNIST APPROACH IN WHICH DETAILS AND DECORATION ARE MINIMAL.



... PROVIDE A HOLISTIC COMPOSITION THAT IS DEFERENTIAL TO ITS HISTORIC CONTEXT. TAKE CUES FROM ADJACENT BRICK DETAILING IN HEADERS, SILLS, SOLIDER COURSING, AND CORNICES. TAKE CUES FROM CORNICE LINE HEIGHTS AND BUILDING PROPORTIONS.

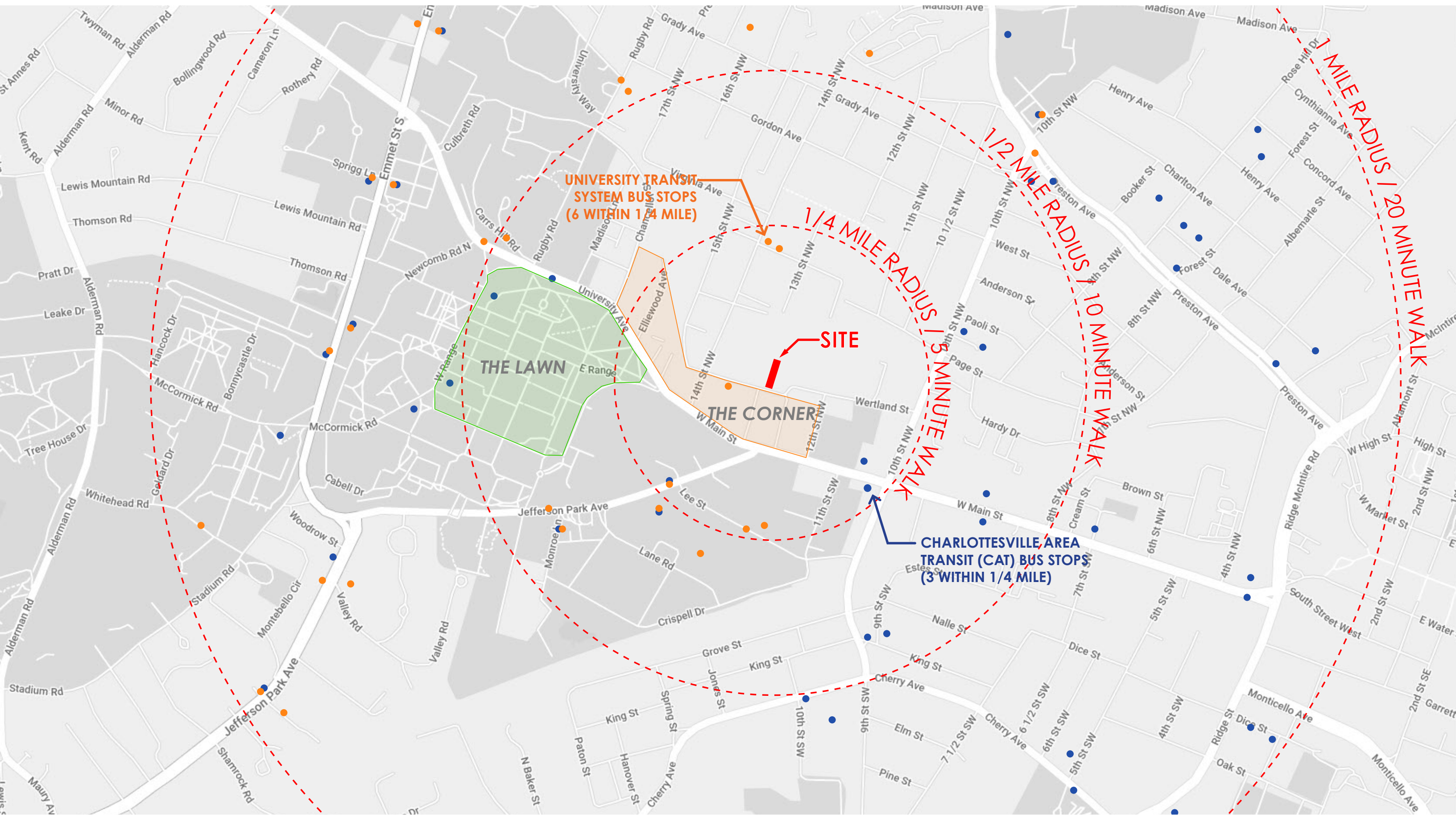





1311 WERTLAND STREET



1310 WERTLAND STREET



1306 WERTLAND STREET



1300 WERTLAND STREET



1250 WERTLAND STREET



1301 WERTLAN STREET



1254 WERTLAND STREET



1256 WERTLAND STREET



216 FOURTEENTH STREET



1215 WERTLAND STREET



WERTENBAKER HOUSE

\* DENOTES A CONTRIBUTING STRUCTURE

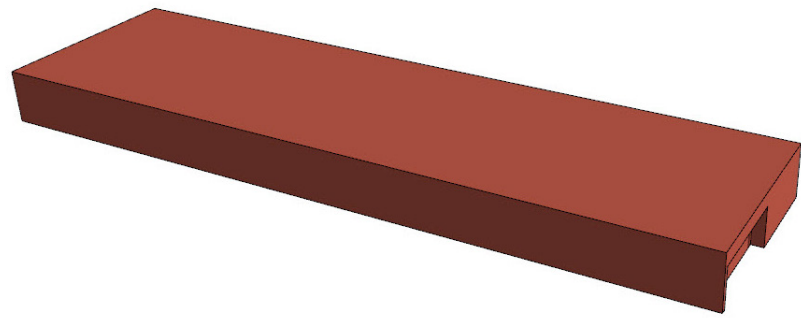

STEP 1: COVER EXISTING SURFACE PARKING LOT

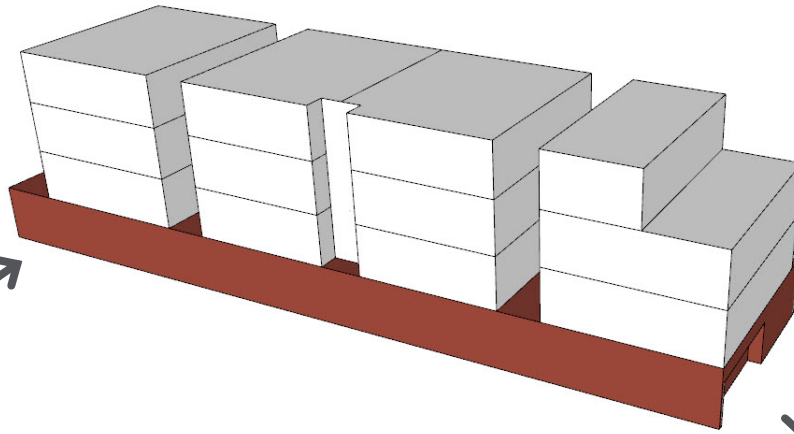

STEP 3: BREAK DOWN MASS THROUGH VERTICAL VOIDS AT STAIR TOWERS AND BALCONIES

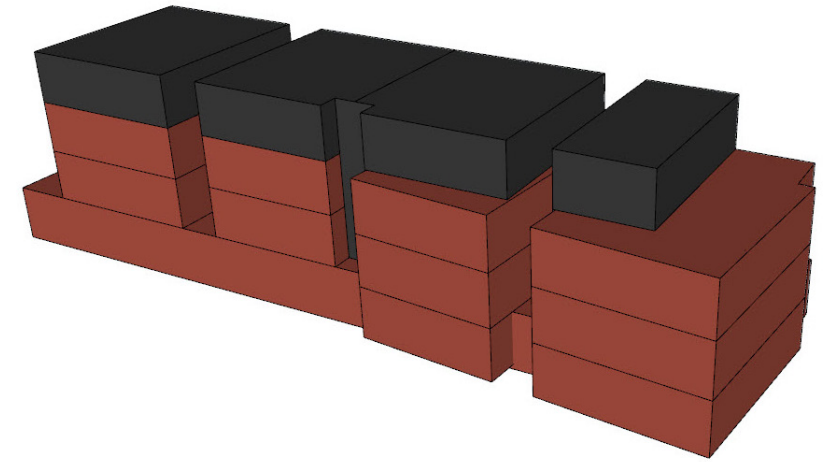

STEP 5: FOR THE PROPOSED BUILDING MASS IN FRONT OF THE WERTENBAKER HOUSE, SKEW THE FORM TO EMPHASIZE THE HISTORIC RELATIONSHIP TO THE STREET

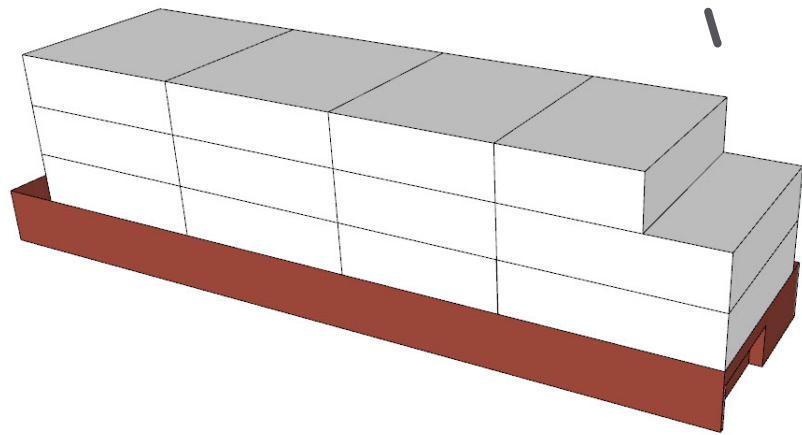

STEP 2: IDENTIFY 12 INDIVIDUAL UNITS, INCORPORATING A STEP BACK FROM THE STREET

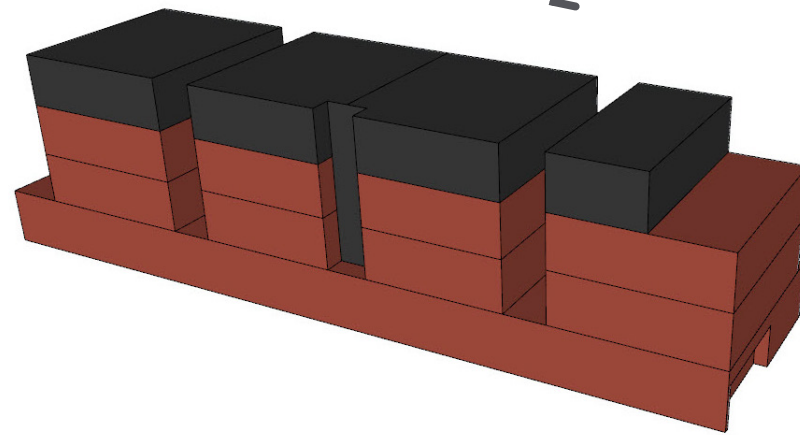

STEP 4: LIMIT THE IMPACT OF HEIGHT BY ESTABLISHING A BRICK MASS THAT IS THE SAME HEIGHT AS THE WERTENBAKER CORNICE LINE

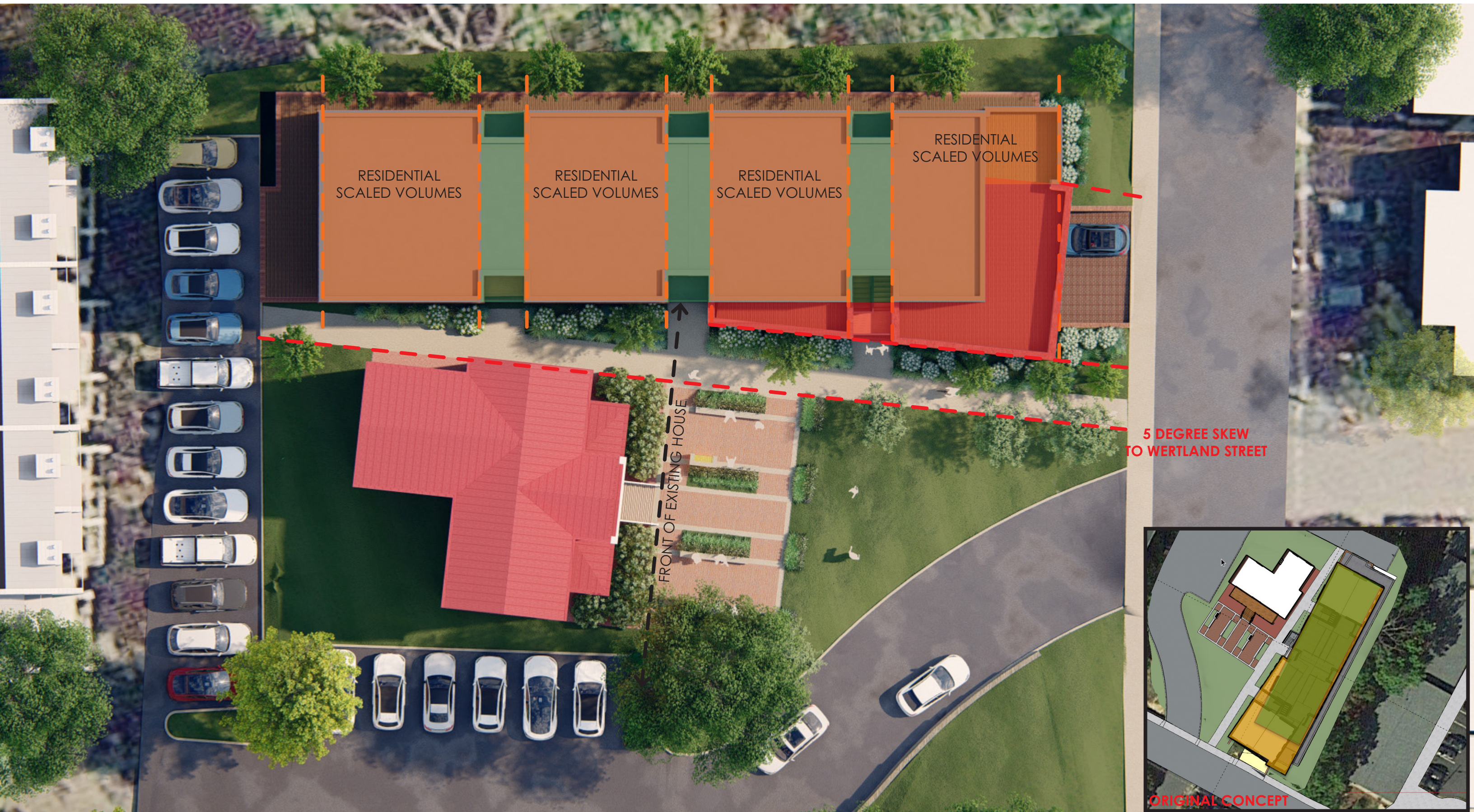

1301 WERTLAND ST.  
CHARLOTTESVILLE, VA

## PROPOSED SITE ORGANIZATION AND DIAGRAM

BAR SUBMISSION  
DECEMBER 27, 2022



1. EMPLOY DESIGN TECHNIQUES TO REDUCE VISUAL PRESENCE. THESE COULD INCLUDE VARYING FACADE WALL PLANES, DIFFERING MATERIALS, STEPPED-BACK UPPER LEVELS, AND IRREGULAR MASSING.
2. ESTABLISHING A DIRECTIONAL RELATIONSHIP BETWEEN THE OLD AND NEW CONSTRUCTION
3. REDUCE LARGER MASSING TO SMALLER-SCALED FORMS BY BREAKING UP THE ROOF LINE, VARYING THE SURFACE OF THE BUILDING, AND STEPPING BACK THE BUILDING AT THE STREET LINE.
4. PROVIDE A VARIED ROOF LINE TO BREAK UP THE MASSING.
5. THE RHYTHM, PATTERNS, AND RATIO OF SOLIDS (WALLS) AND VOIDS (WINDOWS AND DOORS) OF NEW BUILDINGS SHOULD RELATE TO AND BE COMPATIBLE WITH ADJACENT HISTORIC FACADES.
6. REINFORCE THE HUMAN SCALE OF THE HISTORIC DISTRICTS BY INCLUDING ELEMENTS SUCH AS PORCHES, ENTRANCES, STOREFRONTS, AND DECORATIVE FEATURES DEPENDING ON THE CHARACTER OF THE PARTICULAR SUB-AREA.



1. SETBACK FROM WERTLAND STREET HAS INCREASED TO ACCOMMODATE THE SKEWED FRONT ELEVATION.
2. THE FRONT ELEVATION HAS BEEN REVISED TO ACCOMMODATE A PEDESTRIAN ENTRANCE.
3. THE LANDSCAPING AND ASSOCIATED FRONT COURTYARD HAS BEEN THOUGHTFULLY REFINED AND DEVELOPED.
4. EXTERIOR LIGHTING HAS BEEN DESIGNED AND STUDIED FOR COMPLIANCE WITH THE CITY'S BOARD OF ARCHITECTURAL REVIEW GUIDELINES AND ZONING ORDINANCE.
5. EXTERIOR MECHANICAL EQUIPMENT HAVE BEEN LOCATED.



1301 WERTLAND ST.  
CHARLOTTESVILLE, VA

RENDERED SITE PLAN

12

BAR SUBMISSION  
DECEMBER 27, 2022



1301 WERTLAND ST.  
CHARLOTTESVILLE, VA

COURTYARD PERSPECTIVE

13

BAR SUBMISSION  
DECEMBER 27, 2022



1301 WERTLAND ST.  
CHARLOTTESVILLE, VA

EXISTING PERSPECTIVE FROM 13TH STREET

BAR SUBMISSION  
DECEMBER 27, 2022





NEW PEDESTRIAN ENTRANCE AT  
WERTLAND STREET ELEVATION (504)



1301 WERTLAND ST.  
CHARLOTTESVILLE, VA

EXISTING PERSPECTIVE FROM WERTLAND STREET

BAR SUBMISSION  
DECEMBER 27, 2022



1301 WERTLAND ST.  
CHARLOTTESVILLE, VA

PROPOSED PERSPECTIVE FROM WERTLAND STREET

BAR SUBMISSION  
DECEMBER 27, 2022



1301 WERTLAND ST.  
CHARLOTTESVILLE, VA

PROPOSED PERSPECTIVE ON WERTLAND ST.

BAR SUBMISSION  
DECEMBER 27, 2022



1301 WERTLAND ST.  
CHARLOTTESVILLE, VA

CENTRAL PEDESTRIAN AXIS

19

BAR SUBMISSION  
DECEMBER 27, 2022

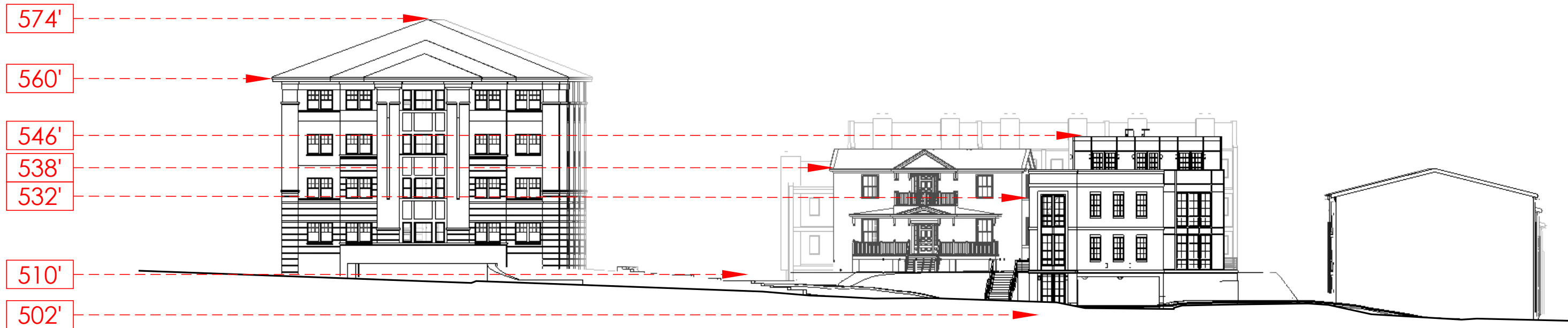

SITE SECTION





1301 WERTLAND ST.  
CHARLOTTESVILLE, VA

WERTLAND STREET ELEVATION (SOUTH)

21

BAR SUBMISSION  
DECEMBER 27, 2022



1301 WERTLAND ST.  
CHARLOTTESVILLE, VA

SIDE ELEVATION (EAST)

22

BAR SUBMISSION  
DECEMBER 27, 2022





1301 WERTLAND ST.  
CHARLOTTESVILLE, VA

COURTYARD ELEVATION (WEST)  
23

BAR SUBMISSION  
DECEMBER 27, 2022



1301 WERTLAND ST.  
CHARLOTTESVILLE, VA

REAR ELEVATION (NORTH)

24

BAR SUBMISSION  
DECEMBER 27, 2022



1301 WERTLAND ST.  
CHARLOTTESVILLE, VA

COURTYARD PERSPECTIVE  
25

BAR SUBMISSION  
DECEMBER 27, 2022

LEGEND

EXISTING FEATURES

- 1 - WILLOW OAK (OFF PROPERTY)
- 2 - TREE, TYP.
- 3 - PROPERTY LINE
- 4 - RETAINING WALL
- 5 - BRICK WALK
- 6 - PORCH
- 7 - STAIR
- 8 - EVERGREEN TREE

PROPOSED FEATURES

- A - LAWN ELLIPSE
- B - BRICK WALK
- C - CONCRETE WALK
- D - SMALL FLOWERING TREE, TYP.
- E - MEDIUM CANOPY TREE, TYP.
- F - COLUMNAR TREE (4' WIDTH MAX)
- G - COLUMNAR TREE (10' WIDTH)
- H - SHRUBS, TYP.
- I - GROUNDCOVER
- J - GRASSES & PERENNIALS, TYP.
- K - GARAGE ENTRY (VEHICULAR)
- L - GARAGE ENTRY (PEDESTRIAN)
- M - STAIR

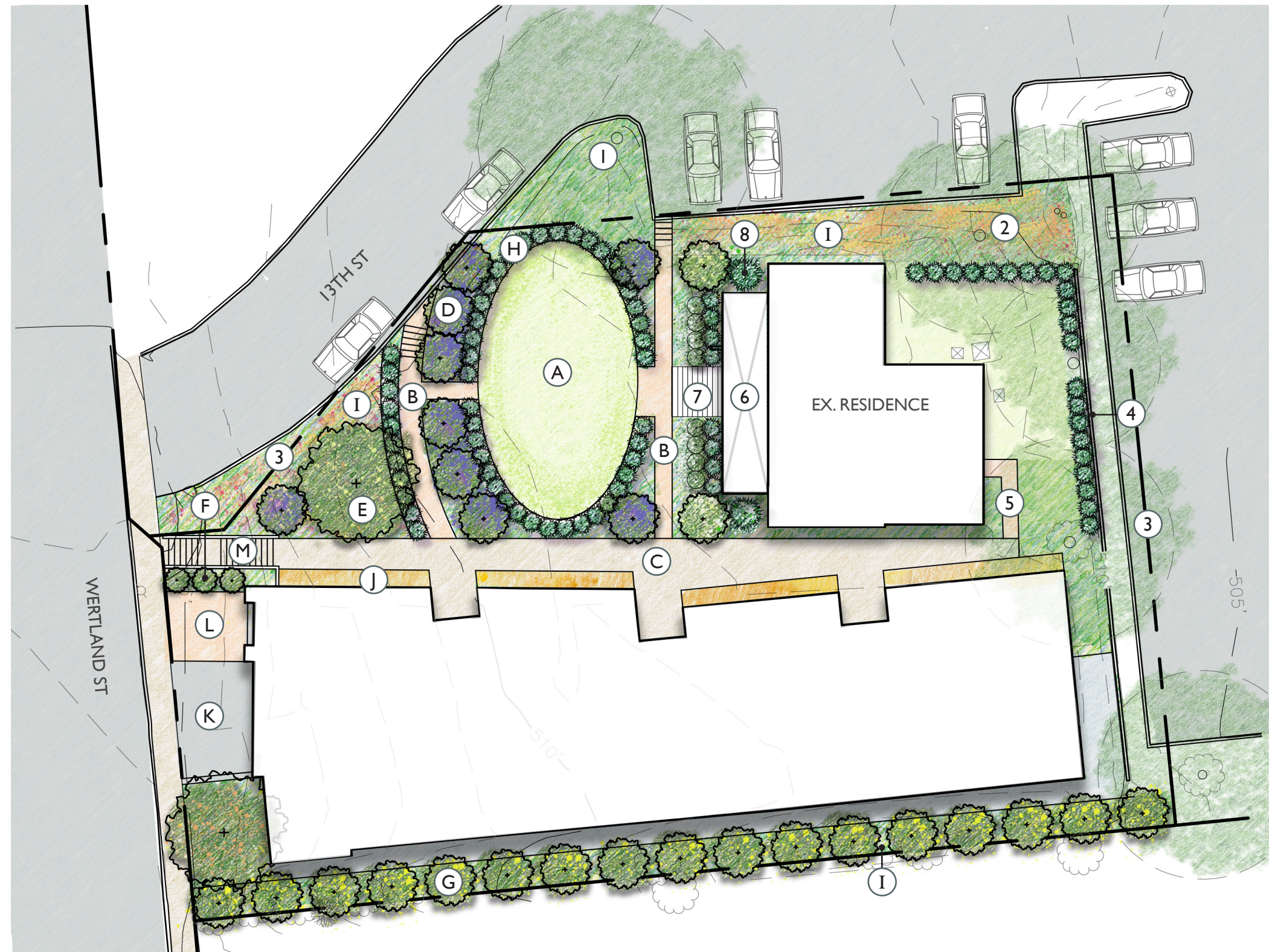

TREES & SHRUBS



Bald Cypress / *Taxodium distichum*



Liquidambar 'Slender Silhouette' / Sweetgum



Yellowwood / *Cladrastis kentukea*



Serviceberry / *Amelanchier 'Autumn Brilliance'*



Sweetbay Magnolia / *Magnolia virginiana 'Moonglow'*



Ginkgo / *Ginkgo 'Princeton Sentry'*



Inkberry Holly / *Ilex glabra 'Shamrock'*

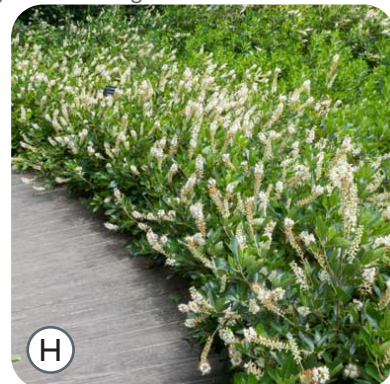

Summersweet / *Clethra alnifolia 'Hummingbird'*



Dwarf Witchalder / *Fothergilla gardenii*



Oakleaf Hydrangea / *Hydrangea quercifolia 'Sikes Dwarf'*



Arrowwood Viburnum / *Viburnum dentatum 'Blue Muffin'*

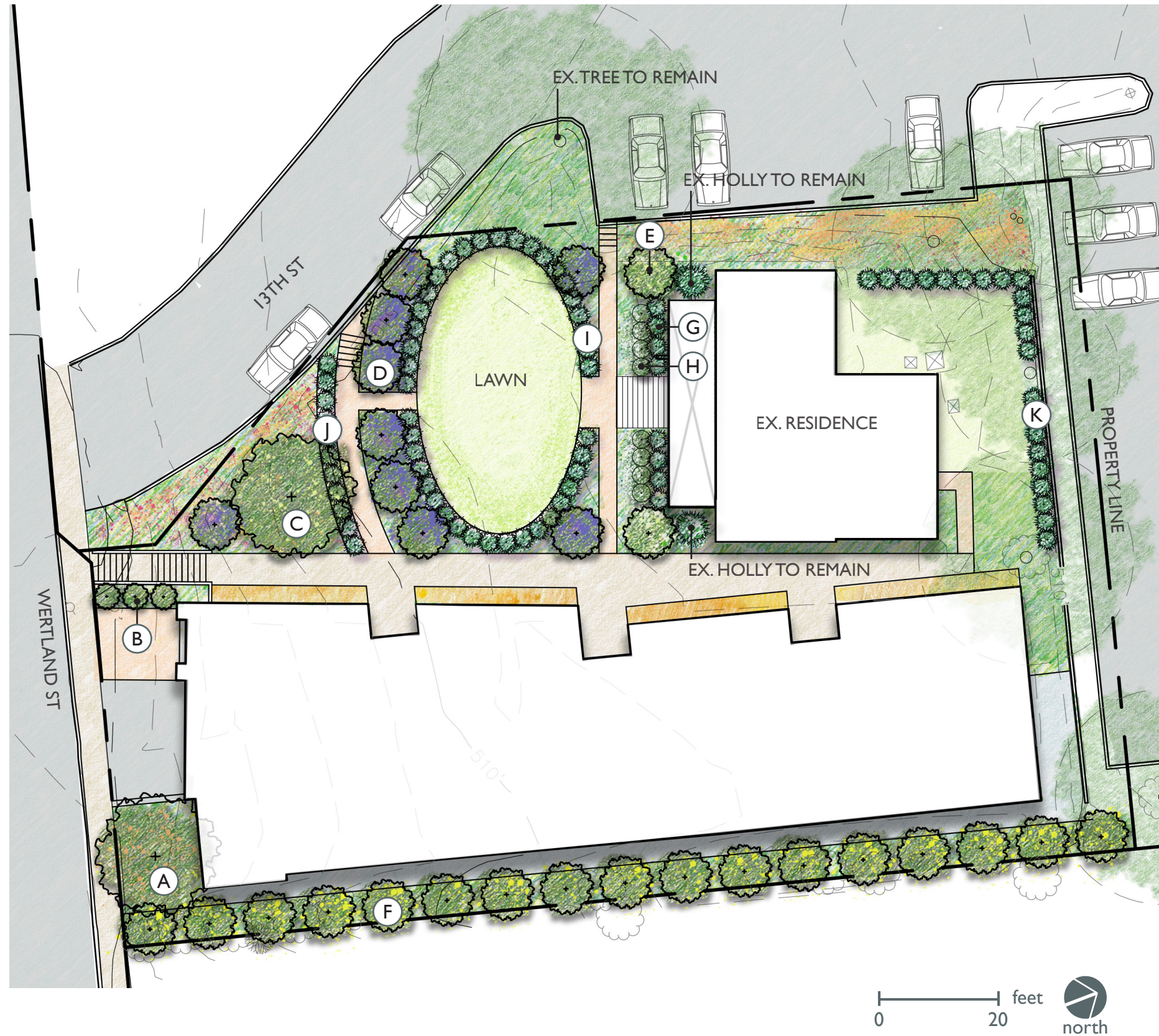

**GROUNDCOVER**



**L**  
Low Gro Sumac / *Rhus aromatica* 'Gro Low'



**M**  
Aronia 'Ground Hog' / Dwarf Black Chokeberry



**N**  
Liriope muscari 'Monroe's White' / White Lily Turf

**GRASS & PERENNIAL MIX**



Threadleaf Bluestar / *Amsonia hubrichtii*



Switchgrass / *Panicum virgatum* 'Shenandoah'

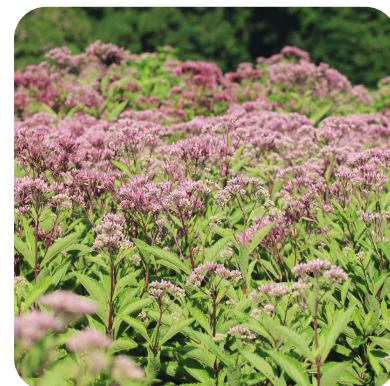

Dwarf Joe Pye Weed / *Eupatorium dubium* 'Baby Joe'



Hyssop / *Agastache* 'Purple Haze'

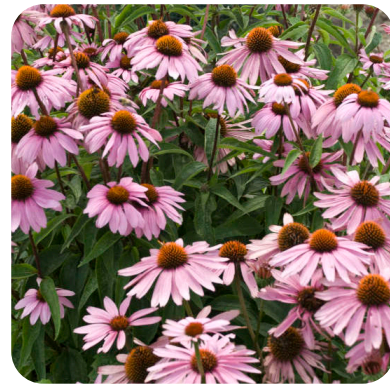

Purple Coneflower / *Echinacea purpurea* 'Magnus'



*Sporobolus heterolepis* / Prairie Dropseed

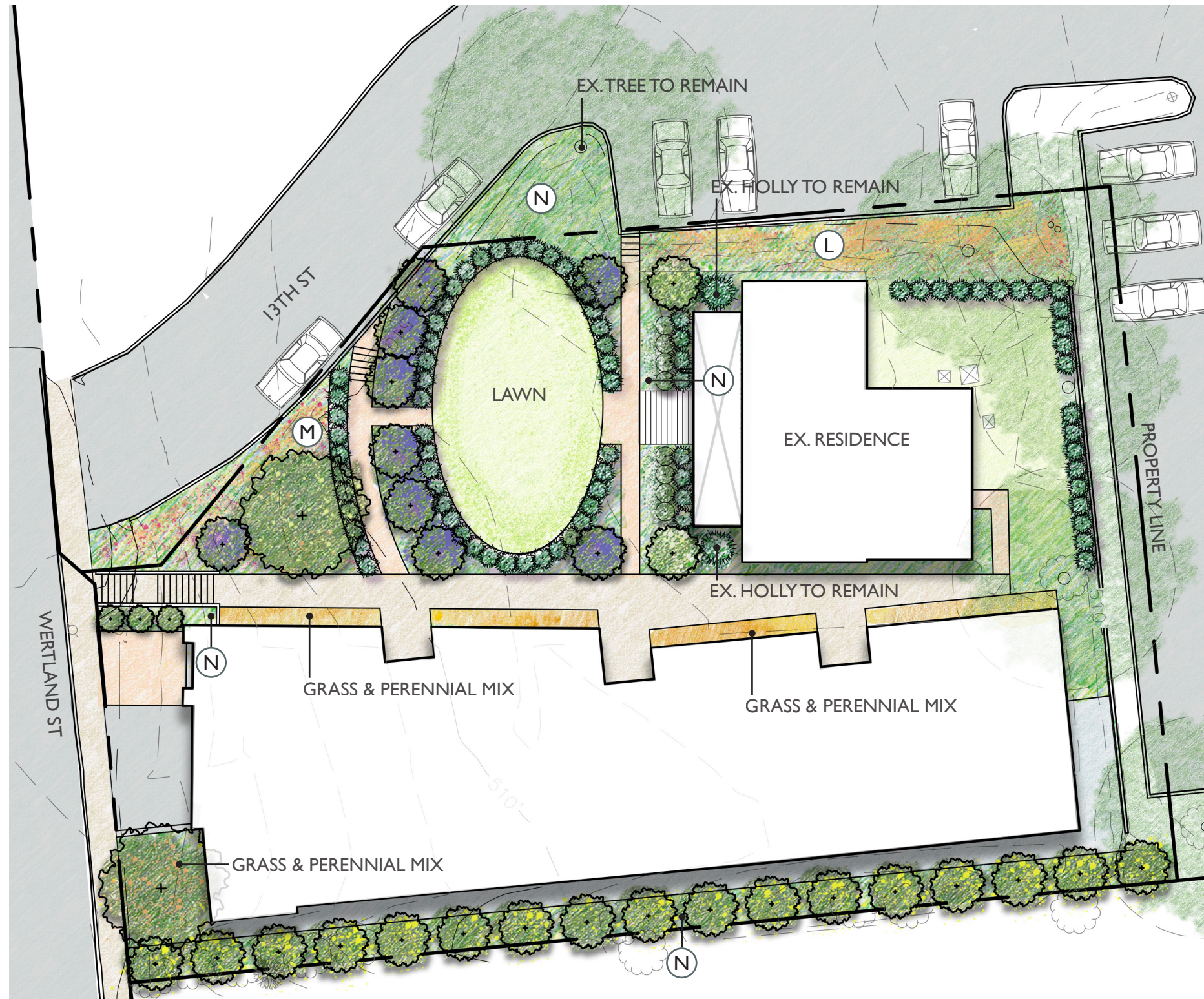

PAVING



A

Sawcut Concrete



B

Brick

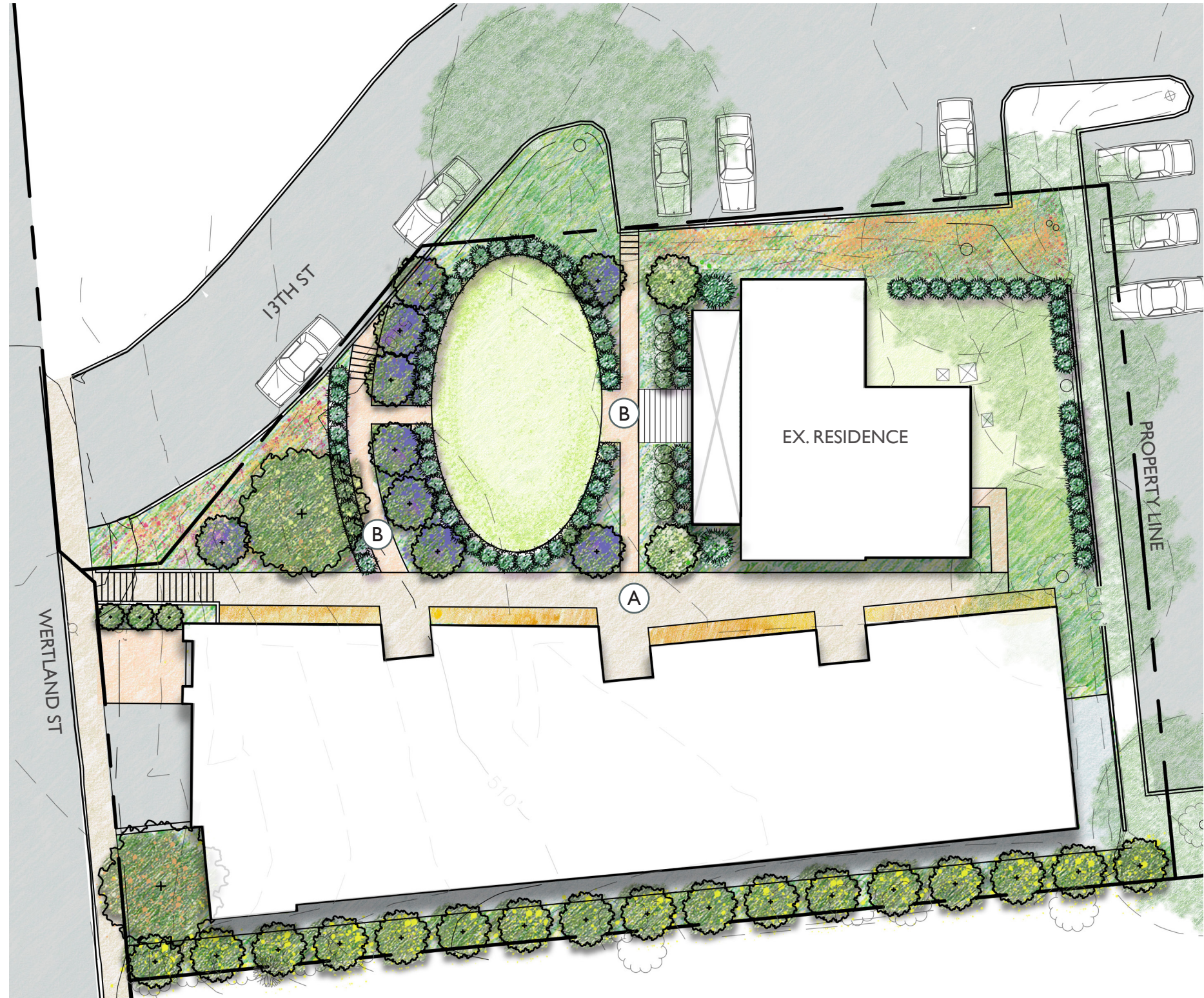



1301 WERTLAND ST.  
CHARLOTTESVILLE, VA

COURTYARD PERSPECTIVE LIGHTING

30

BAR SUBMISSION  
DECEMBER 27, 2022



**BOLLARD LIGHTING**



**Dimensions**

Height (H)	41" (104mm)
Height (A)	40" (1016mm)

Pemco's Full Cutoff Bollards with choice of optics are designed to replace HID lighting systems up to 70w MH or HPS. These fixtures are ideal for retail centers, industrial parks, schools and universities, public transit and airports, office buildings and medical facilities.

**Specifications and Features:**  
**Housing:** Extruded Aluminum Housing with Flush Mounting Base, Flat Top. Bollards Can Be Cut to Custom Lengths Upon Request.  
**Listing & Ratings:** CSA Listed for Wet Locations, ANSI/UL 1598, 8750 IP66 Sealed LED Compartment.

**Finish:** Textured Architectural Bronze or Black Powdercoat Finish Over a Chromate Conversion Coating. Custom Colors Available Upon Request.

**Styles:** 360° Light Distribution, 120° Shield or 180° Shield  
**Lens:** Clear UV-Stabilized Polycarbonate Vandal-Resistant Lens

**Mounting Options:** Mounting Kit with 6" Zinc-Plated Anchor Bolts, Included.  
**EasyLED LED:** Aluminum Base

**Wattage:** 360° Arrays: 12w & 16.6w; System: 12.9w & 18.9w  
180° & 120° Arrays: 10w & 15.5w; System: 11.2w & 17w; (70w HID Equivalent)

**Driver:** Electronic Driver, 120-277V, 50/60Hz, Less Than 20% THD and PF>0.9. Standard Internal Surge Protection 2kV, 0-10V Dimming Standard for a Dimming Range of 10% to 100%, Dimming Source Current is 150 Microamps.

**Controls:** Fixtures Ordered with Factory-Installed Motion Sensor Controls are Internally Wired for Switching and/or 1-10V Dimming Within the Housing. Remote Direct Wired Interface of 1-10V Dimming is Not Included and May Not Be Available. Please Consult Factory. Fixtures are Tested with LEPC Controls and May Not Function Properly With Controls Supplied By Others. Fixtures are NOT Designed for Use with Line Voltage Dimmers.

**Warranty:** 5-Year Warranty for -40°C to +50°C Environment.  
See Page 2 for Projected Lumen Maintenance Table.

Quick Ship option for Standard heights & colors only

Order Information Example: **CAV150QF1X17U4KZ30SP**

Model	Driver	CCT	Lens	Color	Height	Options
CAV150QF1X12-Full Cutoff Bollard - 360°, 12w	U=120-277V	3K=3000K	C=Clear	Z=Bronze	30=30" Height	SP=Single Fuse (120-277V Only)
CAV150QF1X17-Full Cutoff Bollard - 360°, 16.6w		4K=4000K	L=UV-Stabilized Polycarbonate Vandal-Resistant Lens	B=Black	42=Standard Height	CF=Control Fuse (120-277V Only)
CAV150P1X10-Full Cutoff Bollard with 120° Shield, 10w		5K=5000K		C=Custom (Consult Factory)	30=30" Height	SP=Single Protection
CAV150P1X15-Full Cutoff Bollard with 120° Shield, 15.5w						SP=Single Protection
CAV150P1X10-Full Cutoff Bollard with 180° Shield, 10w						SP=Single Protection
CAV150P1X15-Full Cutoff Bollard with 180° Shield, 15.5w						SP=Single Protection

**BOLLARD LIGHTING**

**Accessories & Replacement Parts:**

Mounting Accessories (Order Separately, Field Installed)	Accessories (Order Separately, Field Installed)	Replacement Parts (Order Separately, Field Installed)
<b>BREASE*</b> Bollard Retrofit Base Kit Adapts New Bollards to Existing Bolt Patterns. Fits all LED Bollards. Die Cast with Powdercoat Finish. Hardware Included. 11" Dia. x 11" H. <b>P17122</b> Remote Programming Tool for P17121 <b>P17121</b> Adapter Plate with Gaskets for Older Bollards. Fits LEPC Round Bollards. Die Cast with Bronze Powdercoat Finish.	<b>P17122</b> Remote Programming Tool for P17121 <b>BOADP1</b> Adapter Plate with Gaskets for Older Bollards. Fits LEPC Round Bollards. Die Cast with Bronze Powdercoat Finish.	<b>P17121</b> Adapter Plate with Gaskets for Older Bollards. Fits LEPC Round Bollards. Die Cast with Bronze Powdercoat Finish.

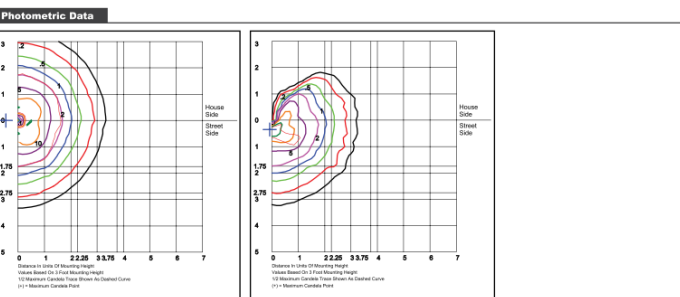

**CAV150QF1X17U4KZ30SP** 360° Open, Clear Glass Lens  
Grid in feet, Mounting Height = 3 ft.

**CAV150P1X16U4KZ30SP** 180° Shield, Clear Glass Lens  
Grid in feet, Mounting Height = 3 ft.

**SONARAY**  
www.sonarayled.com

**SONARAY**  
www.sonarayled.com

**OBI Light Bar**

**FEATURES**

- Durable aluminum housing with polycarbonate lens
- Black, White, and Aluminum finishes
- Narrow, Medium, and Wide lighting distributions
- Several mounting options to fit any application
- Serial Connection option to daisy-chain multiple light bars
- 0-10V Dimmable standard
- IP69K and IP69 rated
- Field tested to 3000 PSI
- 5 Year Warranty



**APPLICATIONS**  
• Food Processing • Classroom • Signage • Parking Garage • Tunnel

**ORDERING GUIDE**

SERIES	WATTAGE	LENGTH	BEAM ANGLE	LENS	CRI	CCT	FINISH	VOLTAGE
✓ LB4	✓ 50 90w	5 FOOT	N 18 DEGREE	C CLEAR	✓ 8	✓ 20 3000K	✓ BLK BLACK	✓ L 120-277V
	060 90w	M 4 FOOT	M 18 DEGREE	F FROSTED	✓ 8	40 4000K	WHT WHITE	L 120-277V
		L 4 FOOT	✓ VW 120 DEGREE		50	5000K	ALM ALUMINUM	

**SERIAL CONNECTION**

SERIAL CONNECT	CACT	NSFM	M2	M3	M5
✓ SS SERIAL CONNECT	✓ CCM SINGLE UNIT, Ceiling Mount for Channel Mount	✓ NSFM SINGLE UNIT, Ceiling Mount for Smooth Mount	✓ M2 MULTIPLE UNITS, (5) Light Bars	✓ M3 MULTIPLE UNITS, (5) Light Bars	✓ M5 MULTIPLE UNITS, (5) Light Bars

**LED SPECIFICATION**

MODEL	WATTS	OPTIC	LENS	3000K LUMENS EFFICACY	4000K LUMENS EFFICACY	5000K LUMENS EFFICACY	WEIGHT (lbs.)	CERTIFICATION
LB-4030	29	N	C	3,160 109 lm/W	3,227 111 lm/W	3,362 116 lm/W	2.25 / 3.75	DLC, ETL
	29	M	C	3,084 106 lm/W	3,150 109 lm/W	3,281 113 lm/W	2.25 / 3.75	DLC, ETL
	28	WW	C	4,384 157 lm/W	4,477 160 lm/W	4,664 167 lm/W	2.25 / 3.75	DLC, ETL
LB-4060	28	WW	F	3,973 142 lm/W	4,058 145 lm/W	4,227 151 lm/W	2.25 / 3.75	DLC, ETL
	59	N	C	6,123 104 lm/W	6,253 106 lm/W	6,514 110 lm/W	3.75 / 5.25 / 6.75	DLC, ETL
	59	M	C	5,852 99 lm/W	5,976 101 lm/W	6,225 106 lm/W	3.75 / 5.25 / 6.75	DLC, ETL
	57	WW	C	8,650 152 lm/W	8,834 155 lm/W	9,202 161 lm/W	3.75 / 5.25 / 6.75	DLC, ETL
	57	WW	F	7,670 135 lm/W	7,833 137 lm/W	8,160 143 lm/W	3.75 / 5.25 / 6.75	DLC, ETL

**OBI Light Bar**

**SPECIFICATIONS**

**CONSTRUCTION**  
The body of the OBI Light Bar is made of just a few extruded aluminum and polycarbonate pieces, making it both a rugged and resilient luminaire as well as one with an architectural aesthetic. The NSF-rated version of the OBI Light Bar has no channels or areas where water can collect, thereby eliminating the potential for algae or mold growth.

**ELECTRICAL**  
The OBI Light Bar comes standard with a high-performance driver that goes from 100-277V, Power Factor > 9 with THD < 2, internal to the fixture. A minimum CRI of 80 is provided in 3000K, 4000K, and 5000K color temperatures. 4kV surge protection and 0-10V dimmable standard. Bars have a 6' power cord with longer lengths available on request.

**INSTALLATION**  
Available options include pendant and flush mounting options for individual units. For combined units bracketed together there are additional options for both how they bracket together, as well as mount to fixed structures or pendant. All necessary hardware is included with the brackets.

**OPTICS**  
An offering of 30°, 60°, or 120° beam angles are available for all OBI Light Bars to cover all potential application needs. The 30° and 60° options are produced with a clear lens while the 120° option can be clear or frosted.

**WARRANTY**  
All OBI Light Bar products come with a limited Five (5) Year Warranty. For more information regarding the warranty please contact the factory at (844) 202-5606 or email Customer Service at LEDCustService@dascom.com.

**CERTIFICATIONS AND LISTINGS**  
ETL certified to UL 1598, DesignLights Consortium Standard qualified product for all models. Suitable for Wet Locations and Natatoriums. Certified to NSF/ANSI 2, IP69K and IP69 Rated. Ambient Operating Temperature: -20°C ~ +45°C / -4°F ~ +113°F.

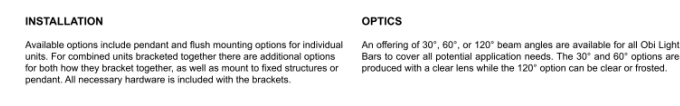

**SERIAL CONNECTION**

Note: Please be aware of the connection limitations (number of units) per below table.

INPUT VOLTAGE	LB-4030	LB-4060
AC	@110v: s10pcs @220v: s20 pcs @277v: s26 pcs	@110v: s10pcs @220v: s10 pcs @277v: s13 pcs
DC	@24: s6 pcs	@24: s3 pcs

**WALL FAUC SERIES**

Wide Round Outdoor Wall Cylinder with Photocell

Type: \_\_\_\_\_ Fixture: \_\_\_\_\_

**TECHNICAL DATA**

PRODUCT	VANCP-7L	VANCP-15L
SIZE	7.5"	11.5"
WATTAGE	9W	18W
LUMENS	750 LM	1500 LM
EFFICACY	83 LM/W	
CC	Color Changeable - 3000K/4000K/5000K	
VOLTAGE	120-277V	
LIGHT DIRECTION	1	2
BEAM ANGLE	50°	
CRI	80+	
POWER FACTOR	0.9	
WORKING TEMP.	-40°F ~ 113°F	
FINISH	BLACK, BRONZE	
DIMMING	NON DIMMING	

**DESCRIPTION**  
Our Wide LED Round Outdoor Wall Cylinder creates a unique lighting effect for any outdoor environment. The die cast aluminum design helps the fixture resist rust. The high quality reflector creates a 50° beam angle as well. Color adjustable, you can choose either 3000K, 4000K, or 5000K with a simple switch. The photocell allows the fixture to automatically turn on/off depending on the time of day.

**INTENDED USE**  
This Wide LED Round Outdoor Wall Cylinder creates a cozy ambiance that is great for indoor and outdoor projects such as decks, front doors, porches, patios, gardens, corridors, balconies, villas, and walkways. The fixture is Wet location rated and suitable for severe weather conditions.

**ORDERING INFORMATION**

Series: \_\_\_\_\_ Lumen Package: \_\_\_\_\_ CC: \_\_\_\_\_ Finish: \_\_\_\_\_

Series	Lumen Package	CC	Finish
VANCP (Wide Cylinder Vanity Wall Light with Photocell)	7L (750 lm, 9W) 15L (1500 lm, 18W)	CC Color Changeable (3000K/4000K/5000K)	BK (Black) BZ (Bronze)*

\*Additional cost and/or lead time on customized fixtures may apply. Please contact your sales rep for more information.

**WALL FAUC SERIES**

Wide Round Outdoor Wall Cylinder

Type: \_\_\_\_\_ Fixture: \_\_\_\_\_

**TECHNICAL DATA**

PRODUCT	VANCP-7L	VANCP-15L
SIZE	7.5"	11.5"
WATTAGE	9W	18W
LUMENS	750 LM	1500 LM
EFFICACY	83 LM/W	
CC	Color Changeable - 3000K/4000K/5000K	
VOLTAGE	120-277V	
LIGHT DIRECTION	1	2
BEAM ANGLE	50°	
CRI	80+	
POWER FACTOR	0.9	
WORKING TEMP.	-40°F ~ 113°F	
FINISH	BLACK, BRONZE	
DIMMING	NON DIMMING	

**DESCRIPTION**  
Our Wide LED Round Outdoor Wall Cylinder creates a unique lighting effect for any outdoor environment. The die cast aluminum design helps the fixture resist rust. The high quality reflector creates a 50° beam angle as well. Color adjustable, you can choose either 3000K, 4000K, or 5000K with a simple switch. The photocell allows the fixture to automatically turn on/off depending on the time of day.

**INTENDED USE**  
This Wide LED Round Outdoor Wall Cylinder creates a cozy ambiance that is great for indoor and outdoor projects such as decks, front doors, porches, patios, gardens, corridors, balconies, villas, and walkways. The fixture is Wet location rated and suitable for severe weather conditions.

**ORDERING INFORMATION**

Series: \_\_\_\_\_ Lumen Package: \_\_\_\_\_ CC: \_\_\_\_\_ Finish: \_\_\_\_\_

Series	Lumen Package	CC	Finish
VANCP (Wide Cylinder Vanity Wall Light with Photocell)	7L (750 lm, 9W) 15L (1500 lm, 18W)	CC Color Changeable (3000K/4000K/5000K)	BK (Black) BZ (Bronze)*

\*Additional cost and/or lead time on customized fixtures may apply. Please contact your sales rep for more information.



**PHOTOCELL SETTINGS**

The fixtures with a built-in photocell automatically turn off during daylight hours.

- The light is always **ON** when luminance is < 90 lux (night time).
- The light is always **OFF** when luminance is > 90 lux (day time).

WALL PROJECTION 6.25"

**PARKING GARAGE SERIES**

Parking Garage Uplight

Type: \_\_\_\_\_ Fixture: \_\_\_\_\_

**TECHNICAL DATA**

PRODUCT	PGUL-63L	PGUL-98L	PGUL-126L
WATTAGE	45W	70W	90W
LUMENS	6300 LM	9800 LM	12600 LM
UPLIGHT	8.9%	11.4%	14.8%
EFFICIENCY	140 LM/W		
CCT	5000K		
VOLTAGE	120 - 277V		
DIMMING	1 - 10V		
CRI	70		
POWER FACTOR	0.9		
WORKING TEMP.	-22°F ~ 104°F		
FINISH	WHITE		

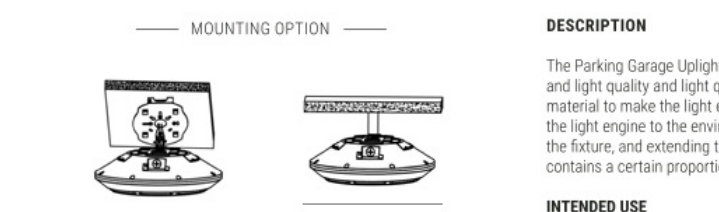

**DESCRIPTION**  
The Parking Garage Uplight has a cast aluminum design aiding in better cooling and light quality and light quality. The optical lens is made of high quality PC material to make the light even and soft. The die cast heat sink transfers heat from the light engine to the environment, via large cooling fins, drawing heat away from the fixture, and extending the lifespan of the LEDs. The Parking Garage Uplight also contains a certain proportion of upward light to satisfy the visual effect.

**INTENDED USE**  
Our Parking Garage series is widely used for indoor and outdoor applications, including wet locations. The Parking Garage Uplight is excellent for museums, art galleries, shopping malls, parking garages, and many more applications.



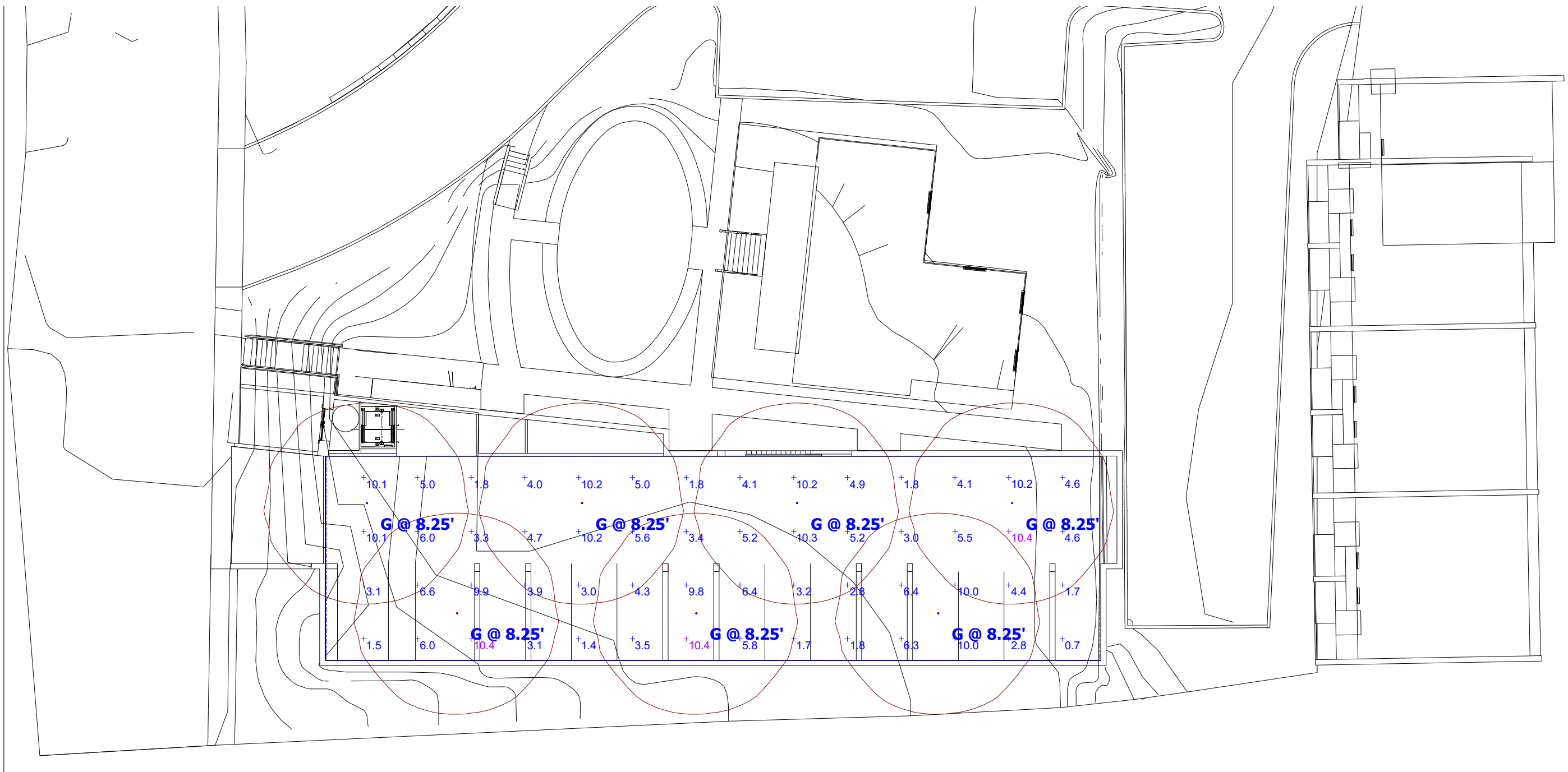

GARAGE LEVEL PHOTOMETRIC PLAN  
SCALE: 1" = 20'

**Statistics**

Description	Symbol	Avg	Max	Min	Max/Min	Avg/Min
GARAGE	+	5.5 fc	10.4 fc	0.7 fc	14.9:1	7.9:1

**Schedule**

Symbol	Label	Image	QTY	Manufacturer	Catalog	Description	Lamp Output	Intensity Multiplier	LLF	Total Output	Input Power	Efficiency	Distribution	Polar Plot	Notes
G	G		7	Spitzer Lighting	PGUL-63L-50K-C1-W	Parking garage fixture with uplight, surface mounted with J-box, 0-10 dimmable, suitable for wet locations.	6344	1	1	6344	0	100%			

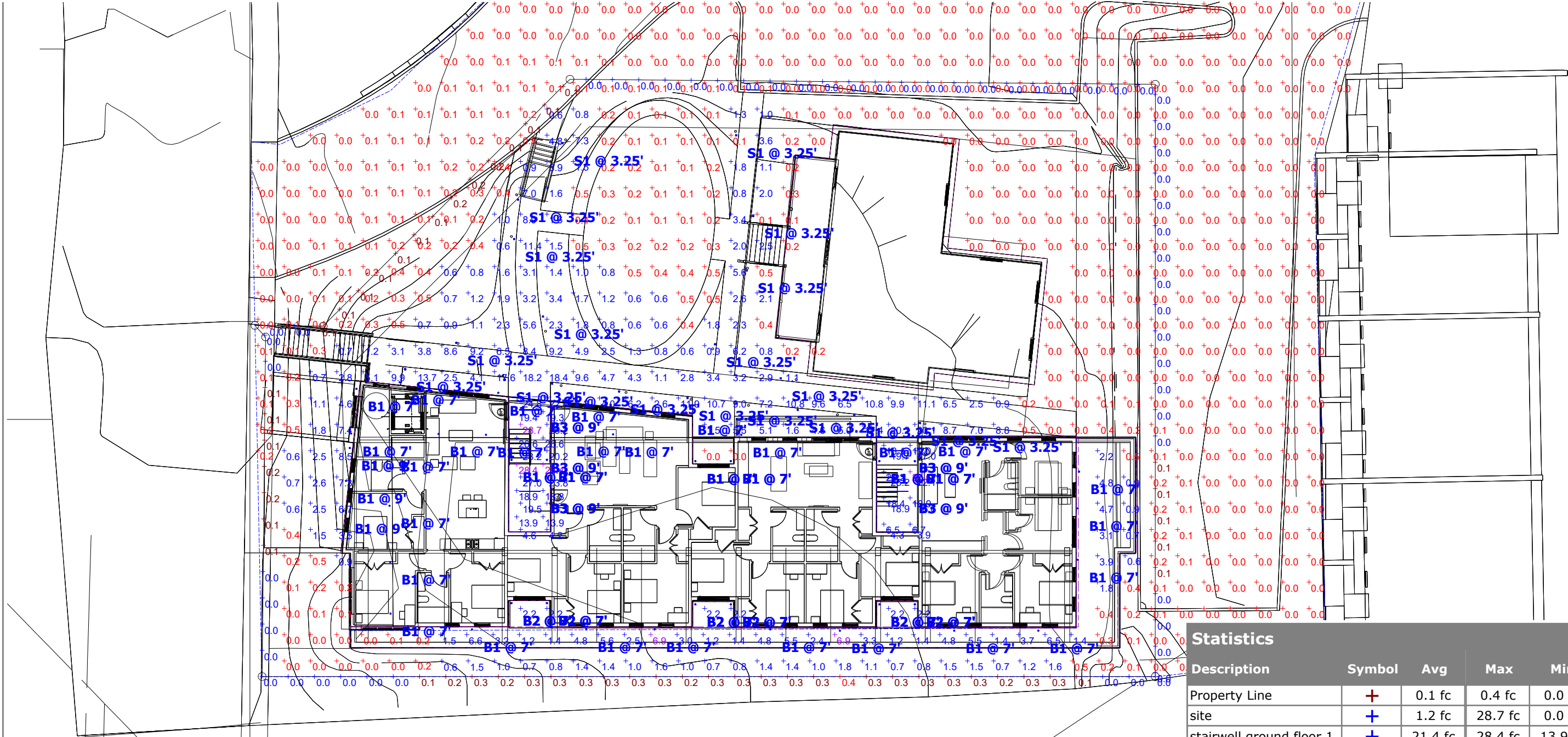

COURTYARD LEVEL PHOTOMETRIC PLAN  
SCALE: 1" = 20'

Statistics						
Description	Symbol	Avg	Max	Min	Max/Min	Avg/Min
Property Line	+	0.1 fc	0.4 fc	0.0 fc	N/A	N/A
site	+	1.2 fc	28.7 fc	0.0 fc	N/A	N/A
stairwell ground floor 1	+	21.4 fc	28.4 fc	13.9 fc	2.0:1	1.5:1
stairwell ground floor 2	+	17.3 fc	25.6 fc	6.5 fc	3.9:1	2.7:1
back deck courtyard lvl	+	2.8 fc	6.9 fc	0.0 fc	N/A	N/A

Schedule															
Symbol	Label	Image	QTY	Manufacturer	Catalog	Lamp Output	Intensity Multiplier	LLF	Total Output	Input Power	Efficiency	Description	Distribution	Polar Plot	Notes
	S1		20	PEMCO LIGHTING PRODUCTS	CAV15QF1X16U4K	488	1	1	488	18.5	100%	Full Cutoff landscape bollard with anchor bolt attachment, 3000k, standard 40" height, 180-DEGREE SHIELD, ONE 16W QSSI LED ARRAY, black finish			
	B1		42	Spitzer Lighting	VANCWP-15L-30K-BK	1279	1	1	1279	18.42	100%	Outdoor Building Wall Sconce, switchable CCT, 3000k, up/dn output, frosted lens, black finish			
	B2		18	Spitzer Lighting	VANCWP-7L-30K-BK	700	1	0.5	700	9	100%	Outdoor Building Wall Sconce, switchable CCT, 3000k, dn output, frosted lens, black finish			
	B3		10	SONARAY	Obi LB-4030M-WWC830 3000K 120	4384	1	1	4384	28	100%	Ceiling mounted outdoor rated strip light, 3000K, 120° frosted lens distribution, end to end connection, black finish			

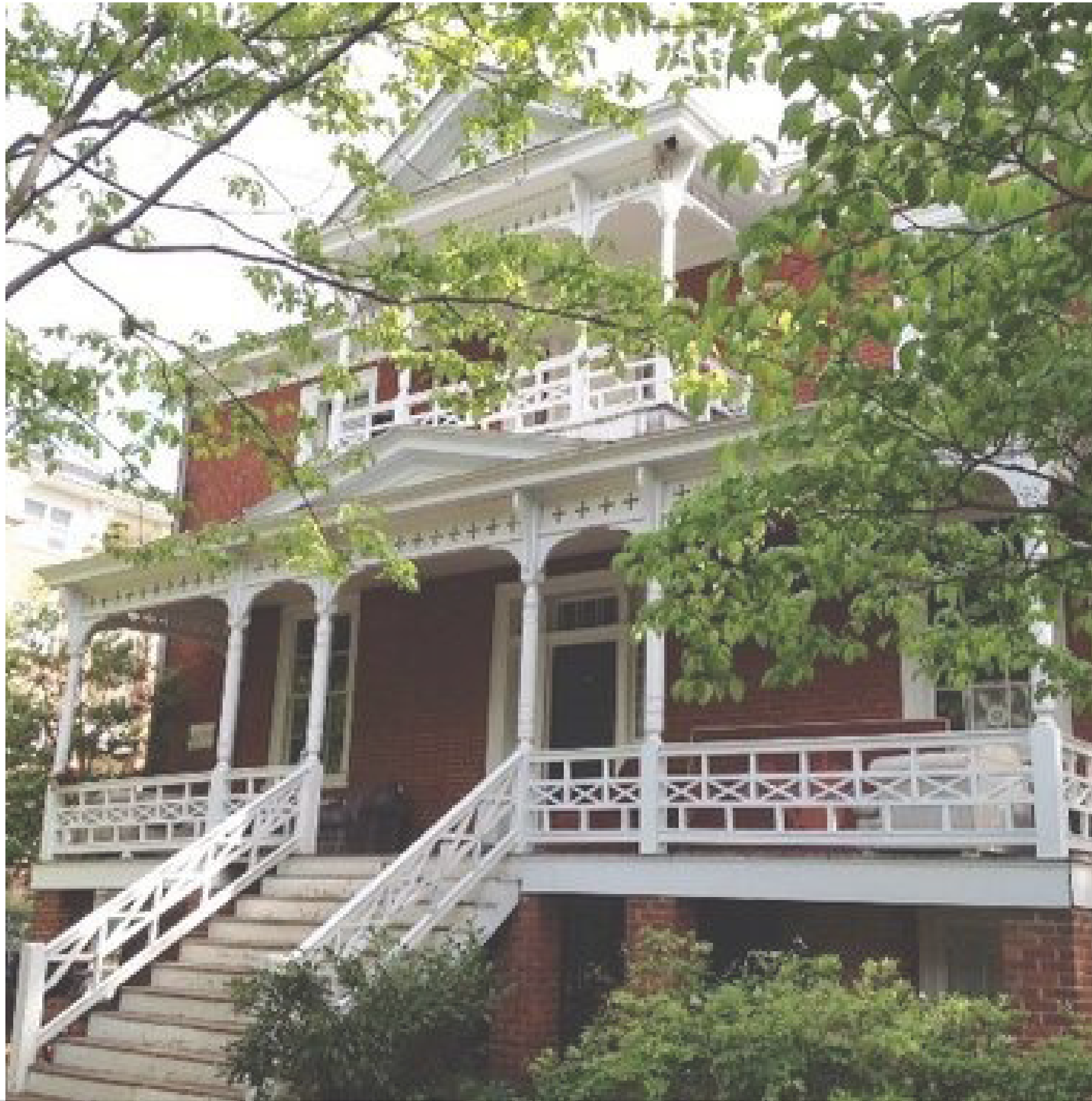

1301 WERTLAND ST.  
CHARLOTTESVILLE, VA

EXISTING HISTORIC HOUSE MATERIAL STUDY



MEASUREMENT OF EXISTING BRICK  
ON HISTORIC WERTENBAKER HOUSE



MEASUREMENT OF EXISTING BRICK  
ON HISTORIC WERTENBAKER HOUSE



COMPLIMENTING EXISTING BRICK

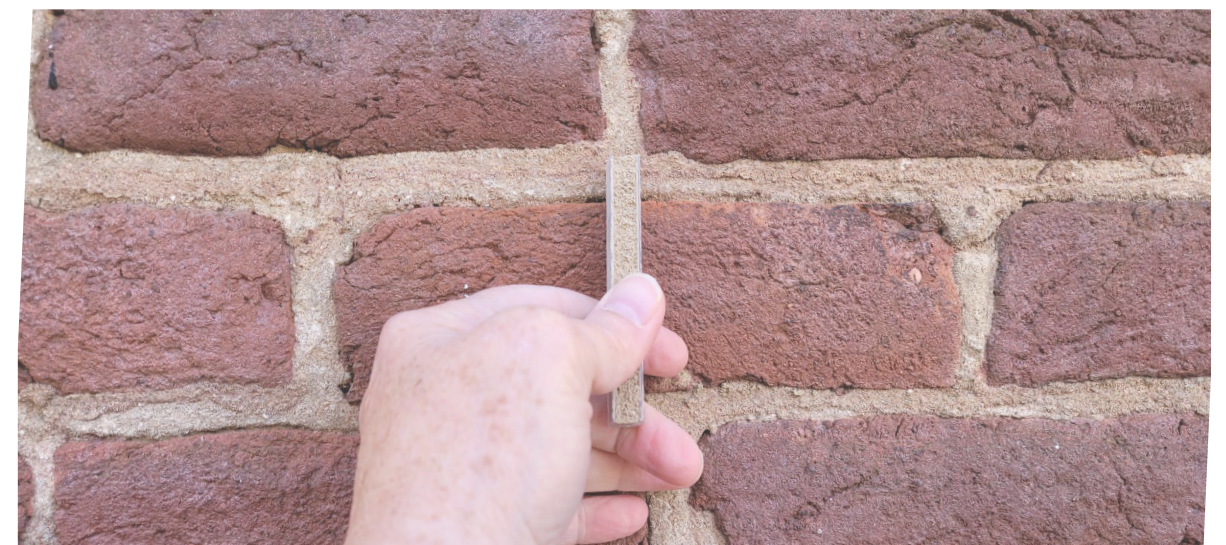

COMPLIMENTING EXISTING MORTAR

BAR SUBMISSION  
DECEMBER 27, 2022



TREX ENHANCED NATURAL DECKING  
"COASTAL BLUFF"

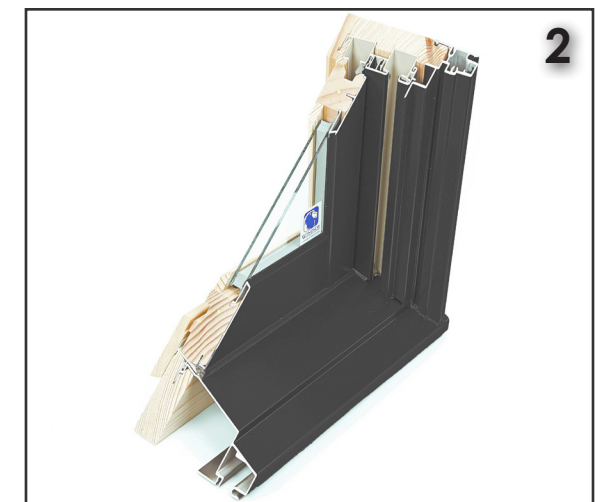

WINDSOR PINNACLE ALUMINUM  
CLAD WOOD WINDOWS IN "SABLE"



SMOOTH FIBER CEMENT TRIM  
BENJAMIN MOORE "MIDNIGHT OIL"



JAMES HARDIE VERICAL BOARD AND  
BATTEN SIDING PAINTED BENJAMIN  
MOORE "MIDNIGHT OIL"

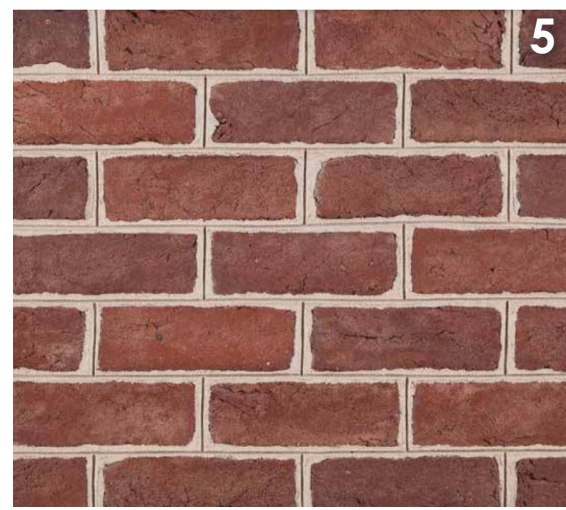

OLD CAROLINA BRICK COMPANY  
HANDMADE BRICK IN "WINDSOR"



ARGOS "SAN TAN" MORTAR



CUSTOM STEEL RAILINGS  
PAINTED BENJAMIN MOORE'S  
"MIDNIGHT OIL"

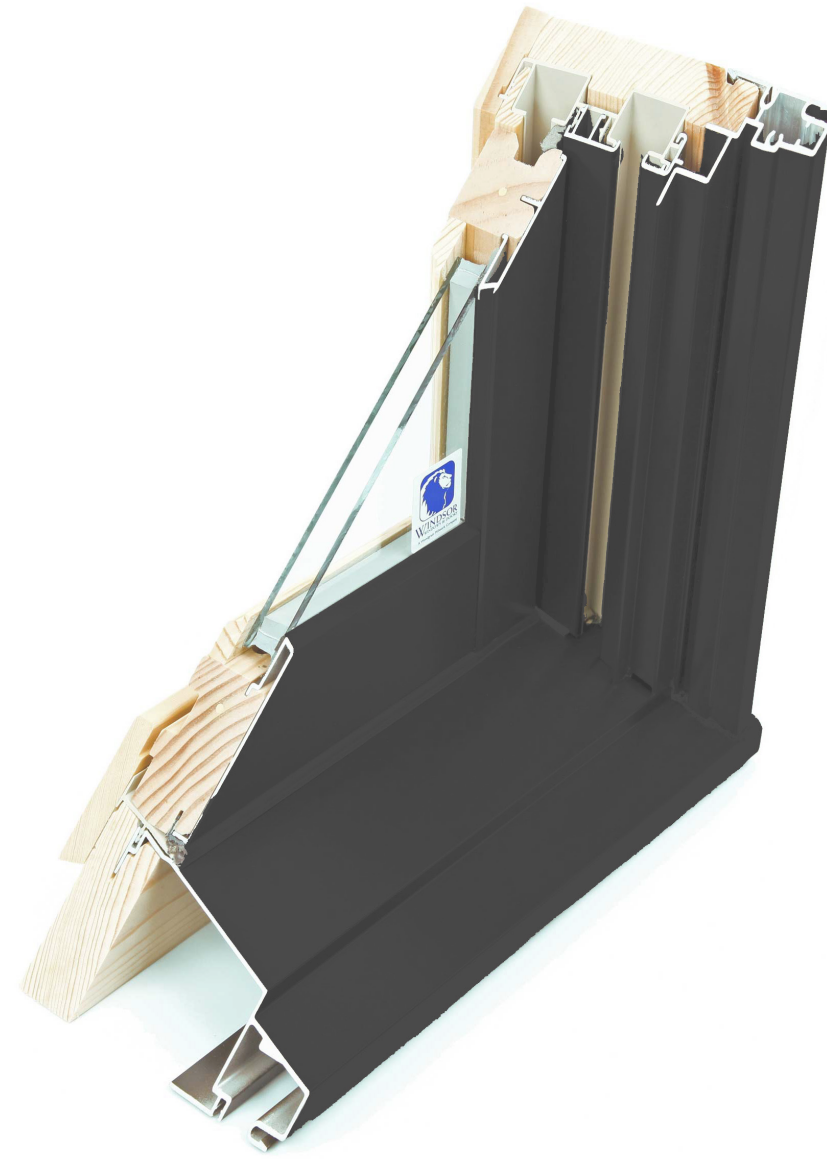

EXTERIOR ALUMINUM CLAD COLOR SELECTION - "SABLE"



INTERIOR STAINED FINISH "ESPRESSO"

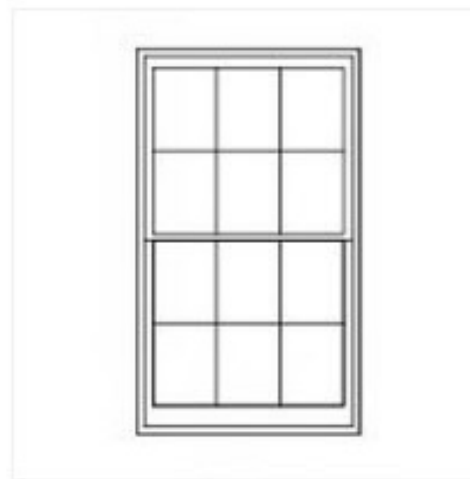

Colonial



5/8", 7/8", 1-1/4" & 2" Short Contemporary Grille

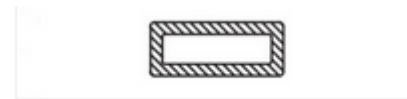

5/8" Short Exterior Grille - Contemporary



5/8 Interior Grille - Contemporary

Steel Exterior Door: 1-Panel

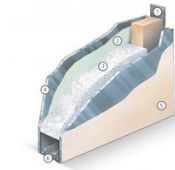
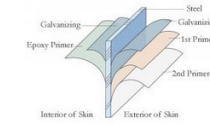
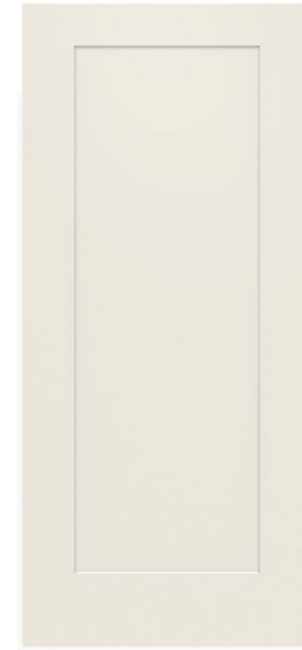

Steel Construction

JELD-WEN Steel exterior doors are durable and affordable. They include wood stiles and rails with mitred top corners to prevent water absorption. Galvanized steel facings are factory primed with neutral, low-sheen, baked-on enamel primer for easy finishing.

Steel Edge

(1) Epoxy primer on the back of the steel resists corrosion (2) Energy efficient core (3) Tough steel (4) Two coats of neutral, low-sheen, baked-on primer for easier finishing (5) Steel bottom rail



WINDSOR EXTERIOR WINDOWS AND PATIO DOORS IN "SABLE"



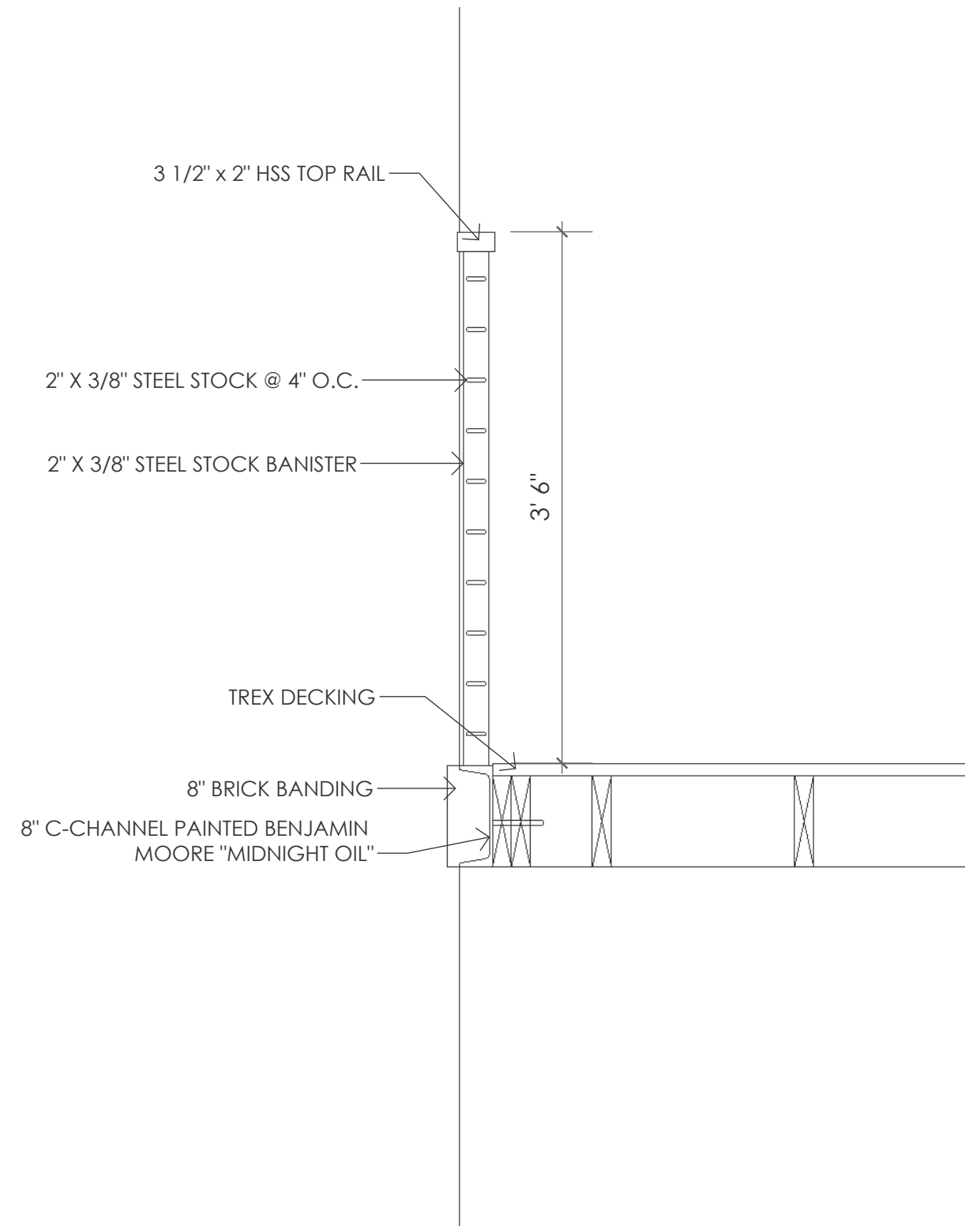
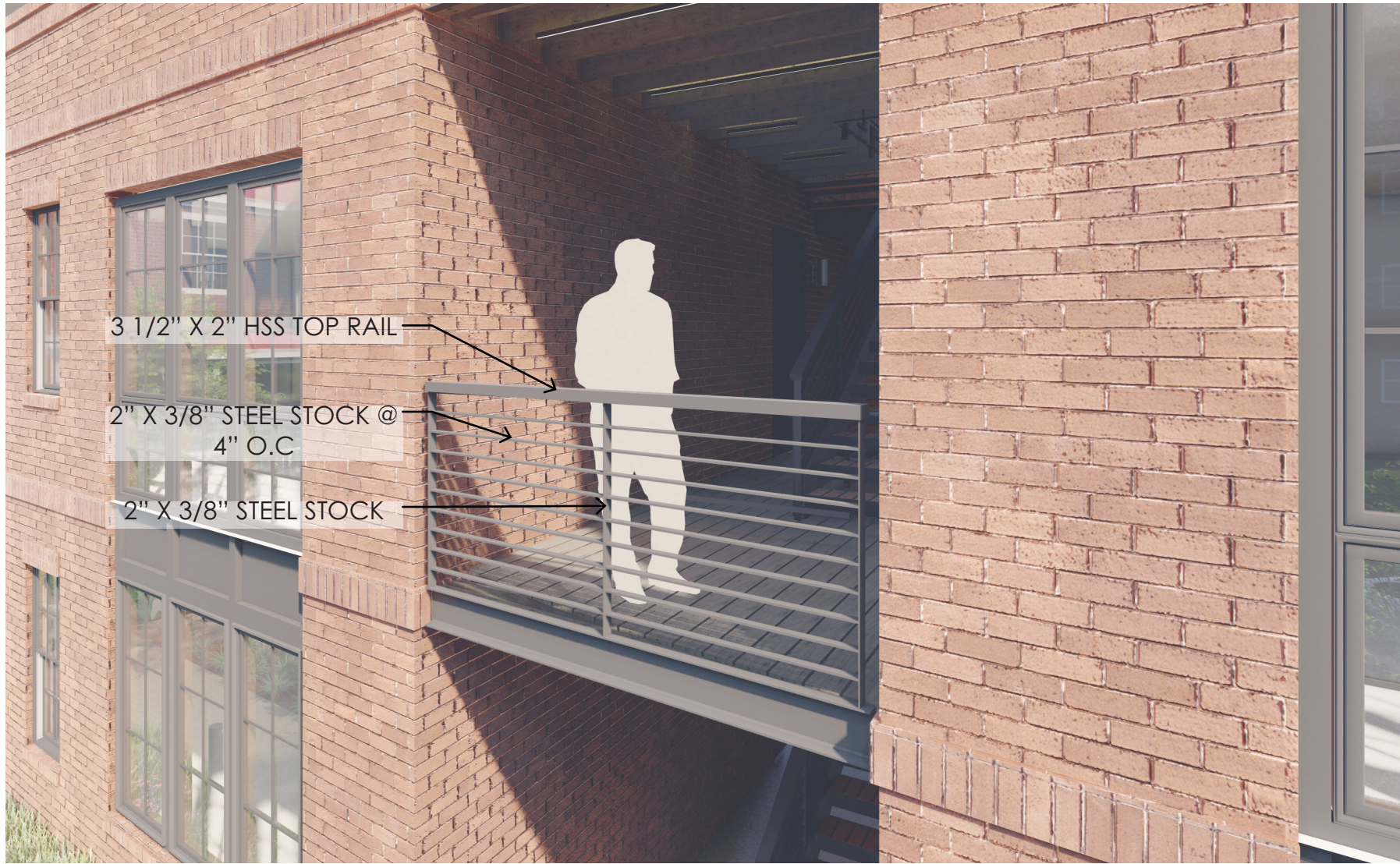

4 SECTION @ TYPICAL EXTERIOR DECK  
 A5.2 1" = 1"







# APPENDIX ONE: ARCHITECTURAL ELEVATIONS

546' - 0" (33'-0")  
T/ PARAPET

534' - 0" (21'-0")  
THIRD FLOOR

523' - 6" (10'-6")  
SECOND FLOOR

513' - 0" (0'-0")  
FIRST FLOOR

505' - 0" (-8'-0")  
STREET LEVEL

502' - 0" (-11'-0")  
PARKING LEVEL



SOUTH ELEVATION

546' - 0" (33'-0")  
T/ PARAPET

534' - 0" (21'-0")  
THIRD FLOOR

523' - 6" (10'-6")  
SECOND FLOOR

513' - 0" (0'-0")  
FIRST FLOOR

505' - 0" (-8'-0")  
STREET LEVEL

502' - 0" (-11'-0")  
PARKING LEVEL



NORTH ELEVATION





Revised Sheet 18



**Entrance at garage**



**Ceiling boards**

# LANDMARK



# SURVEY

## IDENTIFICATION

Street Address: 1301 Wertland Street  
 Map and Parcel: 4-303  
 Census Track & Block:  
 Present Owner: Dyer, Anne F. Humphrey's et. al.  
 Address: P.O. Box 3114, University Station  
 Charlottesville  
 Present Use: Residential  
 Original Owner: William Wertenkaker  
 Original Use: Residential

## BASE DATA

Historic Name: Wertenkaker House  
 Date/Period: Circa 1830  
 Style: Federal  
 Height to Cornice:  
 Height in Stories: 2  
 Present Zoning: B-1 and R-3  
 Land Area (sq.ft.): 80,586 sq. ft.  
 Assessed Value (land + imp.): 35,600 + 150 = 35,750

## ARCHITECTURAL DESCRIPTION

1301 Wertland Street is a brick "L" shaped house on a high basement. The leg of the "L" is a later addition but is of similar construction. The front section of the house is three bays in length and the nearly square back section covers two bays of this length. The main section with a gently sloping metal gable roof has solid brick and gable walls and inside end chimneys. The back section has a large chimney on one side and a hipped roof of the same height as the gable of the main block with which it intersects. There is a bracketed cornice with plain frieze running around the entire house. Besides the fine brickwork the most notable feature of the house is the elaborate symmetrical stick style porch. This is open underneath and supported to the level of the first floor by large square brick posts. It is reached by a broad flight of eight wooden stairs. Carved posts support the low metal roof creating symmetrical end bays and a central bay of equal size flanked by small bays and surmounted by a low pediment. The central second floor porch repeats the design of the entrance section with a larger pediment. An intricate railing runs between the posts on both levels and the porch exhibits definite stick style characteristics which date it later than the house.

## HISTORICAL DESCRIPTION

This house was built around 1830 (possibly as early as 1816) by William and Louisiana Wertenkaker. The land was generally known as the Wertenkaker property (ACDB 87-385) and previously included a house built by C. C. Wertenkaker (William's son) on one side and on the other side a house built for rental to students. William Wertenkaker was chosen by Jefferson as the second Librarian of the University and served over fifty years. He was also sheriff and postmaster. It appears that the Wertenkakers acquired some of the land from James Dinsmore who died in 1830. He had a brick storehouse, kitchen and smokehouse in the vicinity of the present building (ACDB 36-319). In 1886 6 1/2 acres of land originally owned by William Wertenkaker (and sold by his son who moved) containing the present house were sold in three lots. Lot 1 containing the present house was sold to Charles Venable and James Jones (DB 1-314) who sold it to M. W. Humphreys (who had been renting the house) on Oct. 27, 1891 (DB2-449). The present owners are the heirs of M. W. Humphreys who bequeathed the property (WC30281) to his children with a provision that his older child Louise have an option to buy it. Upon her death it was bequeathed to the present owner.



## CONDITIONS

Poor

## SOURCES

Mrs. Alice Flinn, 12 Elliewood Ave., Charlottesville  
 Mrs. J. Rawlings Thomson, 729 Northwood Ave., Charlottesville  
 County Records, City Records

## RECONNAISSANCE LEVEL SURVEY REPORT

DEPARTMENT OF HISTORIC RESOURCE  
RECONNAISSANCE SURVEY FORM*Reviewed by Margaret Peters*

DHR Identification Number: 104-0047

Other DHR Number: Property Date(s) 1830 ca

PROPERTY NAMES	EXPLANATION
Wertenbaker House (1301 Wertland St.)	Historic/Location

County/Independent City: Charlottesville

State: Virginia

Magisterial District: N/A

Tax Parcel: 4-303

USGS Quad Map Name: CHARLOTTESVILLE EAST

UTMs of Boundary:

Center UTM:

Restrict location and UTM data? N

## ADDRESSES

Number	Thoroughfare Name	Explanation
--------	-------------------	-------------

1301 -	Wertland St.	
--------	--------------	--

Vicinity: Town/Village/Hamlet:

Name of National Register Historic District:

Wertland Street Historic District

Name of DHR Eligible Historic District:

Name of Local Historic District:

1301 Wertland Ave. Minor Design Control District

Physical Character of General Surroundings: City

Site Description/Notable Landscape Features:

Landscaped lot with mature oaks completely surrounded by parking lots and modern apartment buildings.

Ownership: Private

NR Resource Type: Building

## WUZITS

Seq. #	# of	Wuzit Types	Historic?
1.0	1	Single Dwelling	Historic

TOTAL:	1	
Historic:	1	
Non-Historic:	0	



PRIMARY RESOURCE EXTERIOR COMPONENT DESCRIPTION

Component	#	Comp Type/Form	Material	Material Treatment
Structural System	0	Masonry	Brick	Flemish Bond
Roof	0	Gable: side	Metal	Standing Seam
Window(s)	0	Sash, double-hung	Wood	6/6
Porch	0	2-story, 5-bay	Wood	Victorian
Chimney	2	Interior	Brick	Stretcher Bond

INDIVIDUAL RESOURCE INFORMATION

SEQUENCE NUMBER: 1.0 WUZIT: Single Dwelling

Primary Resource? Yes

Estimated Date of Construction: 1830 ca

Source of Date: Written Data

Architectural Style: Late Victorian

Description:

Believed to have been built about 1830, the Wertenbaker House is a Federal/Greek Revival residence that was made-over in the Victorian style towards the end of the 19th c. Early exterior features include a symmetrical three-bay front elevation with center entries on both the first and second stories. The first-story entry has a transom, sidelights, and an ornamental surround; the upper entry has sidelights. Victorian features include the front porch, which has five bays on the first story and three on the second, with turned posts, sawn brackets and friezes, an intricate balustrade, and a pedimented gable. The house also has a bracketed cornice that extends to a rear two-story ell. Pre-existing surveys show that the house has Greek Revival and Victorian mantels, paneled pocket doors, and a stair with turned newels and scrolled tread brackets on the interior.

Condition: Good

Threats to Resource: None Known

Additions/Alterations Description:

The chimney tops have been repaired, otherwise there are virtually no post-1900 changes to the exterior.

Number of Stories: 2.0

Interior Plan Type:

Accessed?

Interior Description:

Relationship of Secondary Resources to Property:

DHR Historic Context: Architecture/Community Planning  
 Domestic  
 Education

Significance Statement:

The building is a contributing resource in the Wertland Street Historic District, listed in the National Register of Historic Places. This house--the oldest building in the Wertland Street district--was apparently built about 1830 for William and Louisiana Wertenbaker. William was the second librarian of the University of Virginia, and he served in the post for over fifty years. The house has considerable architectural as well as historical

interest.

#### GRAPHIC DOCUMENTATION

Medium	Medium ID #	Frames	Date
B&W 35mm Photos	14704	37 -	3/ /1996
B&W 35mm Photos	14705	26 - 27	3/ /1996

#### BIBLIOGRAPHIC DATA

Sequence #: 1.0 Bibliographic Record Type: Report  
Author: City of Charlottesville Dept. of Community Devt.  
Citation Abbreviation:  
Historic Resources of Charlottesville, Virginia  
Notes:

Sequence #: 2.0 Bibliographic Record Type: Report  
Author: O'Dell, Jeffrey M.  
Citation Abbreviation:  
VDHR file on the Wertenbaker House  
Notes:

#### CULTURAL RESOURCE MANAGEMENT EVENTS

Date: / /1996  
Cultural Resource Management Event: Reconnaissance Survey  
Organization or Person: J. Daniel Pezzoni, Preservation Con  
ID # Associated with Event:  
CRM Event Notes or Comments:

#### MAILING ADDRESS

Honorif:  
First :  
Last :  
Suffix :  
Title :  
Company: Wertenbaker Associates  
Address: c/o Davis--PO Box 5384  
City : Charlottesville State: VA  
Zip : 22905- Country: USA  
Phone/extension:

Individual Category Codes:

Mailing Address Notes:

Surveyor's Notes:

CITY OF CHARLOTTESVILLE

SEE MAP 5 SEE

MAP

6



SEE MAP

SCALE : 1" = 100'

SECTION 4

104-47

10000000

104-4V

reconnaissance main screen 1 of 7

Where is data filed at DHR?
DHR Iden. #
Other DHR no.

Table with columns: Seq. #, Name, Property Name, Explanation, Hist

Address, Alternate spelling, Former/current, Historic/location, Original

County/Ind. City, State, Mag's District, USGS Quad Map Name, Center UTM-Zone/East/North

reconnaissance main screen 2 of 7

Table with columns: #, Suffix, Thoroughfare Name, Address, Explanation

Sequence Number, Main Street Number, Number Suffix, Street Name

Vicinity of: Town/Village/Hamlet

Name of National Register Historic District, Name of VQHR Eligible Historic District, Name of Local Historic District

reconnaissance main screen 3 of 7

Physical Character of General Surroundings: City, Hamlet, Rural, Suburban, Town, Village

Site Description/Notable Landscape Features: Landscaped lawn w/ mature oaks, lot largely sav'd by p. 100's + mod apt complexes

Ownership, NR Resource Type, B Building, S Site, D District, U Structure, O Object

Summary table with columns: Seq. #, # of, Wuzit Count, Wuzit Types, Historic?, Total, Historic, Non-Historic, Undetermined

reconnaissance main screen 4 of 7
Primary Resource Exterior Component Description

Table with columns: Component, Conn Type/Form, Material, Material Treatment

Individual Resource Information

Seq. #, Wuzit, Primary?, Date Built

Individual Resource Superfield Screen

Sequence Number, Primary Resource?, Estimated Date of Construction, Source of Data

Table with columns: Architectural Style, French Colonial, Late Gothic Revival, Prairie School, etc.

?

Handwritten notes: vint, 1+2-s Ar. porch w/ td posts, dec. bal., sawn brackets, integral 2-s ell w/ top ref + fut down, brick work w/ rot-s, bas't level

Condition, Threats to Resource, Demolished, Excellent, Good, Good-Fair, Poor, Remodeled, Deteriorated, Fair, Good-Excellent, N/A, Rebuilt, Ruinous, Demolition, Development, Neglect, None Known, Relocation, Trans. Expan., Deterioration, Major Alteration, None, Public Util. Expan., Structural Failure, Vacant

Handwritten notes: chim tops rebuilt, otherwise few ext alts.

Number of Stories 2 Conditional Individual Resource Superfield Screen  
 Interior Plan Type \_\_\_\_\_  
 Accessed? \_\_\_\_\_ If not, why not? \_\_\_\_\_  
 Denied No Trespassing Not Accessible

Interior Description \_\_\_\_\_  
 \_\_\_\_\_  
 \_\_\_\_\_  
 \_\_\_\_\_  
 Relationship of Secondary Resources \_\_\_\_\_  
 \_\_\_\_\_

*reconnaissance main screen 5 of 7*  
 Historic Context

DHR Historic Context(s):	Ethnicity/Immigration	Recreation/Arts
Agriculture/Subsistence	Funerary	Religion
Architecture/Landscape Architecture/	Health Care	Settlement Patterns
Community Planning	Industry/Processing/Extraction	Social
Commerce/Trade	Landscape	Traffic Engineering
Domestic	Military/Defense	Transportation
Education		Other

Significance Statement

\_\_\_\_\_

*reconnaissance main screen 6 of 7*  
 Graphic Documentation

Medium*	Medium ID #	Frames	Date
2 x 2 B & W photos	B & W 35 mm photos	Historic photos	Slides
4 x 5 B & W photos	Color 35 mm photos	Measured drawings	

Bibliographic Data

Seq. # \_\_\_\_\_ Type \_\_\_\_\_ Citation \_\_\_\_\_

Bibliographic Superfield Screen

Sequence #: \_\_\_\_\_ Bibliographic Record Type: \_\_\_\_\_ Author: \_\_\_\_\_  
 Citation Abbreviation: \_\_\_\_\_ Notes: \_\_\_\_\_

Bibliographic Superfield Screen

Sequence #: \_\_\_\_\_ Bibliographic Record Type: \_\_\_\_\_ Author: \_\_\_\_\_  
 Citation Abbreviation: \_\_\_\_\_ Notes: \_\_\_\_\_

*reconnaissance main screen 7 of 7*  
 Cultural Resource Management Events

Date	CRM Event	Agency/Individual	Assoc. ID#

CRM Event Superfield Screen  
 Date: \_\_\_\_\_ Cultural Resource Management Event: \_\_\_\_\_  
 Organization or Person: \_\_\_\_\_  
 ID# Associated with Event: \_\_\_\_\_

Notes or Comments

Mailing Address Superfield Screen  
 HONORIF: \_\_\_\_\_ Record Created: \_\_\_\_\_  
 FIRST: \_\_\_\_\_ LAST: \_\_\_\_\_ Last Updated: \_\_\_\_\_  
 SUFFIX: \_\_\_\_\_  
 TITLE: \_\_\_\_\_  
 COMPANY: \_\_\_\_\_ PHONE/EXTENSION: \_\_\_\_\_  
 ADDRESS: \_\_\_\_\_ STATE: \_\_\_\_\_  
 CITY: \_\_\_\_\_ COUNTRY: \_\_\_\_\_  
 ZIP: \_\_\_\_\_ Individual's Category Codes

Informant	Occupant	Owner	Specimens (owner of specimens)	Tenant
Notes				

Surveyor's Notes

Date \_\_\_\_\_ Event \_\_\_\_\_ Data Processing Events Person \_\_\_\_\_

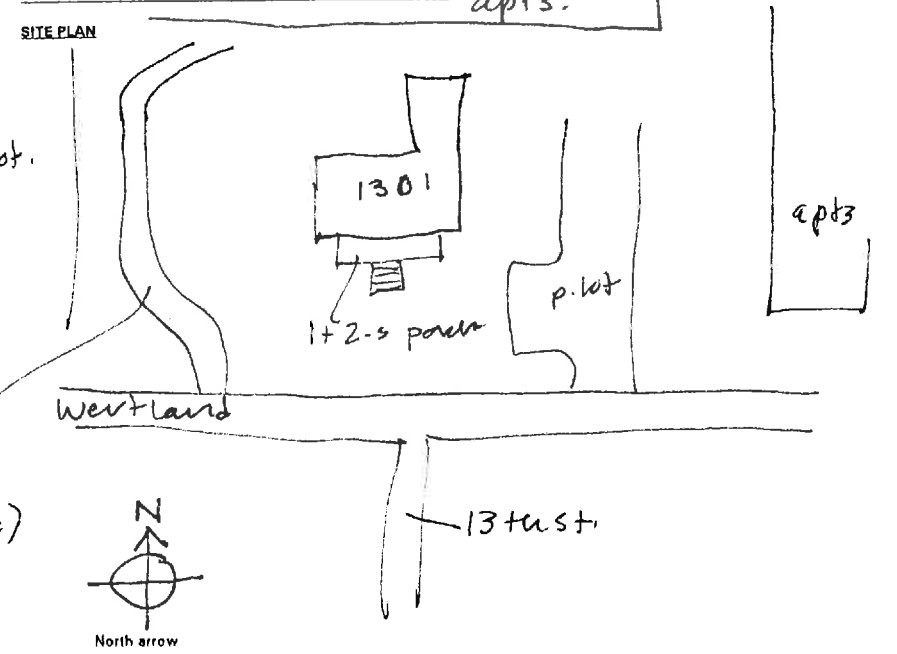

N.T.S.  
 Date: \_\_\_\_\_ Drawn by: \_\_\_\_\_  
 SES - 2/96 Agency: \_\_\_\_\_

1. County  
Town Charlottesville  
Street No. 1301 Wertland St.
- USGS Quad Name  
Quad Date  
Scale  
Original Owner William Wertenbaker  
Original Usedwelling  
Present Owner Mrs. Edward R. Dyer  
Present Owner Address 1301 Wertland St.
- Present Use dwelling (part of house rented)
2. Historic Name Wertland  
Present Name same  
Date or Period ca. 1826  
Architect  
Builder, craftsman, etc.  
Source of Date Mrs. Alicia W. Flynn
3. No. stories (dormers count as  $\frac{1}{2}$  story):  
~~Two~~ over English Basement  
Wall construction: Brick  
Acreage

4. Historical Significance (Chain of Title, Families and Events, etc., connected with the property):

This house was built by William Wertenbaker who was for over fifty years Librarian at the University of Virginia, having been appointed by Mr. Jefferson.

It was later owned by his son, Charles Christian Wertenbaker who sold it to Prof. Milton Humphreys whose daughter Mrs. Edward R. Dyer is now the owner and occupant. Mrs. Dyer was one of the earliest women doctors and for some time served as a medical missionary in the Orient.

Charles Christian Wertenbaker built a house on the NW side of Wertland which was known as "Little Wertland". It was torn down a few years ago and its site is a parking lot for the University Hospital and Medical staff. On the SE side of Wertland the Wertenbaker family built a large building which was rented to students. It also has been torn down and the Wertland Garden Apartments now occupy the site.

Wertland is significant because of the builder and his association with The University and because the street on which it stands was named for it.

5. Architectural Significance (Note interesting interior and exterior details, etc. cite significant alterations and additions).

According to Mrs. Alicia Flynn, Great-granddaughter of the builder, William Wertenbaker planned the house himself. She says that he forgot to include an inside stairway to the kitchen and dining room which were in the basement so that the family always had to go outside to get to the dining room at meal times, apparently this stairway was never added in later years.

6. Condition of structure (check one):

(a) sound \_\_\_\_\_ (b) in need of minor repairs  (c) in need of major repairs \_\_\_\_\_

offers have been made to owner for property. Rumor =  
apt. building on site

1971

Mrs. Alicia W. Flynn  
gt. granddaughter of Wm Wertenbaker

**STREET ADDRESS:** 1301 Wertland Street  
**MAP & PARCEL** 4-303  
**VDHR FILE NUMBER:** 104-007  
**CITY FILE NUMBER:** 163  
**PRESENT ZONING:** B-1  
**ORIGINAL OWNER:** William Wertenbaker  
**ORIGINAL USE:** Residence  
**PRESENT OWNER:** Offices  
**ADDRESS:** Wertenbaker Associates  
c/o Roger Davis  
P. O. Box 5384  
Charlottesville, VA 22905  
**HISTORIC NAME:** Wertland  
**DATE/PERIOD:** 1842, c. 1984  
**STYLE:** Vernacular  
**HEIGHT IN STORIES:** 2 stories  
**DIMENSIONS AND LAND AREA:** 7,598.24 sq. ft.  
**CONDITION:** Good  
**SURVEYOR:** \_\_\_\_\_/Bibb  
**DATE OF SURVEY:** 1973/1987  
**SOURCES:** City/County Records  
Mrs. Alicia W. Flynn  
Mrs. J. Rawlings Thomson

### ARCHITECTURAL DESCRIPTION

The Wertenbaker House is a 2-story, 3-bay single-pile Virginia I-house set on a very high English basement. A 2-story rear wing makes it L-shaped. The foundation of the main block is constructed of brick laid in 5-course American bond. The facade is laid in Flemish bond, while the other walls, as well as both walls and foundation in the rear wing, are 5-course American-with-Flemish bond. The main block of the house has a steep gabled roof covered with standing-seam metal. It has projecting eaves and verges and a cornice with returns, simple brackets, and a plain frieze. The wing has a low pitched hipped roof with matching cornice. There are interior end chimneys in the main block and an interior chimney in the wing. Windows throughout the house are double-sash, 6-over-6 light. Those at the second story and basement levels are somewhat shorter. A one-story verandah, with a smaller one-bay second story porch set on its roof, covers the facade. The verandah has a low-pitched metal roof with a low, pedimented central gable, projecting eaves, a boxed cornice, and a pierced frieze. The upper porch has a higher pitched gabled roof. Both have coupled Eastlake posts and a balustrade combining elements of the stick style with Chinese Chippendale. The central entrance door has three horizontal panels above three vertical ones. Moulded pilasters between the door and sidelights support a cornice. The sidelights and transom have decorative glazing. The corner lights have been closed. A 2-flight stair with a simple Federal balustrade and decorated rail rises from the narrow central hall. The fireplace have coal grates.

### HISTORICAL DESCRIPTION

The Wertenbaker House has been reported to have been built c.1830, or even as early as 1816, but the records do not support that theory. In 1842 William Wertenbaker purchased 27 acres of James Dinsmore's estate (ACDB 39-454). He immediately sold off all



but 6 3/4 acres (ACDB 40-13 & 14), and tax records state that he built this house the same year. Family tradition says that he designed it himself. Later his son C. C. Wertembaker built a house west of this, and the family built a house on the east to rent to students. William Wertenbaker was appointed by Jefferson to be the second librarian at the University. Wertland Street takes its name from this house. William Wertenbaker died in 1882, and his widow sold the property in 1886. James D. Jones bought the house and nearly two acres (City DB 1-314) and sold it in 1891 to M. W. Humphreys, a Greek Professor at the University, who had been renting it (DB 2-449). After his death, it was occupied for many years by his daughter, Dr. Louise H. Dyer, a former medical missionary, and it is now owned by her son Dr. E. R. Dyer (WB 3-281, 25-88).

1987: The house was purchased in 1983 by Wertenbaker Associates (DB 442-204, 444-356) and has been rehabilitated and adapted for use as offices. An apartment complex was built on the land behind the house.

### **STATEMENT OF SIGNIFICANCE**

Built in 1842 when this area was still rural, Wertland is the oldest building in the Wertland Street Historic District. On its own merits, it has already been individually designated as a local historic landmark. Its intricately detailed verandah is particularly noteworthy.

William Wertenbaker was chosen by Thomas Jefferson in 1826 to be the second librarian at the University, and he held that position for over half a century.

1301 WERTLAND STREET

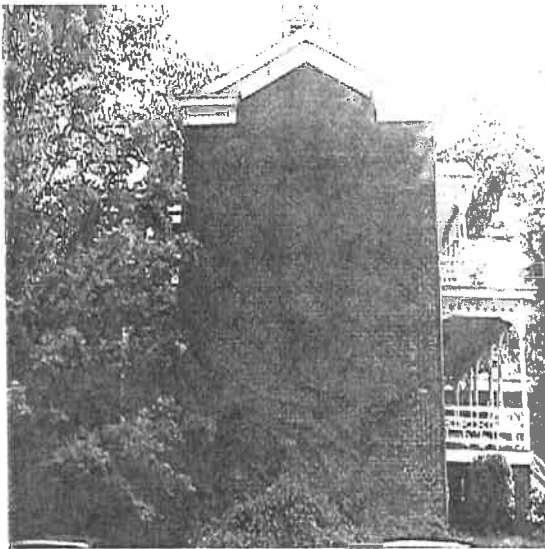

all DB

36-319 Andrew Leitch → Wm Wootenbaker

8/13/1838

Mrs Mary & Ann Dimmore vs Leitch, Wootenbaker, et al:

Jama Dimmore's land on N side rd town → area  $\frac{3}{4}$  acre  
"on which are a brick store & dwelling house & other  
impts (k, smoke, etc)  
bounded on S by Tpk, on E by st bet it & Alex. St C,  
Heiskell (for Dimmore → Peter & Heiskell - Alex. Heiskell),  
on N by Wm Garland (for Dimmore et al), & on W by  
Alex. St C Heiskell (for John Bowman <sup>1835</sup> for Dimmore

middle  
line  
in

39-454 VS Southall <sup>comm</sup> → Wm Wootenbaker

7/20/1842 Andrew Temple, exec Wm Dimmore vs Ann Garland (wid Wm)  
27 acres, part of land sold to Wm Garland by Temple  
W side rd ch'v → Ann

City DB Geo Perkins, commis' in chancery cause of Watson & Perkins  
1-314 vs Wootenbaker, & Mrs Louisiana ~~vs~~ Wootenbaker →

8/17/1858 James D. Jones

2 undivided  $\frac{1}{2}$  int in  $1\frac{17}{20}$  acres, lot 1 on plat A 203

87-385

contract 1855 to Jones & Charles Venable, Jones paid all

see 1847 deed of trust A 203 45-200

see

A & D B Wm & Louisiana Wertenbaker → Eva Crockett

45-200 deed of trust

7/8/1847 c.  $6\frac{3}{4}$  acres bounded on N by Opie Norris est, on E & S by C P McKemie, on S also by st for Univ to Chi<sup>o</sup>, on W by O H Timberlake, ~~St~~ & St Hinkell, McKemie, " & being same land on which sd Wm Wertenbaker now resides"

1842  $7\frac{1}{2}$  → McKemie 40-13 w/ notes & bonds

"  $13\frac{1}{4}$  → N. Garland 40-14 (E of 40-13)

$6\frac{3}{4}$

---

 $27\frac{1}{2}$

ACOB 87-383  
1886 plat of  
Wertenbaker property

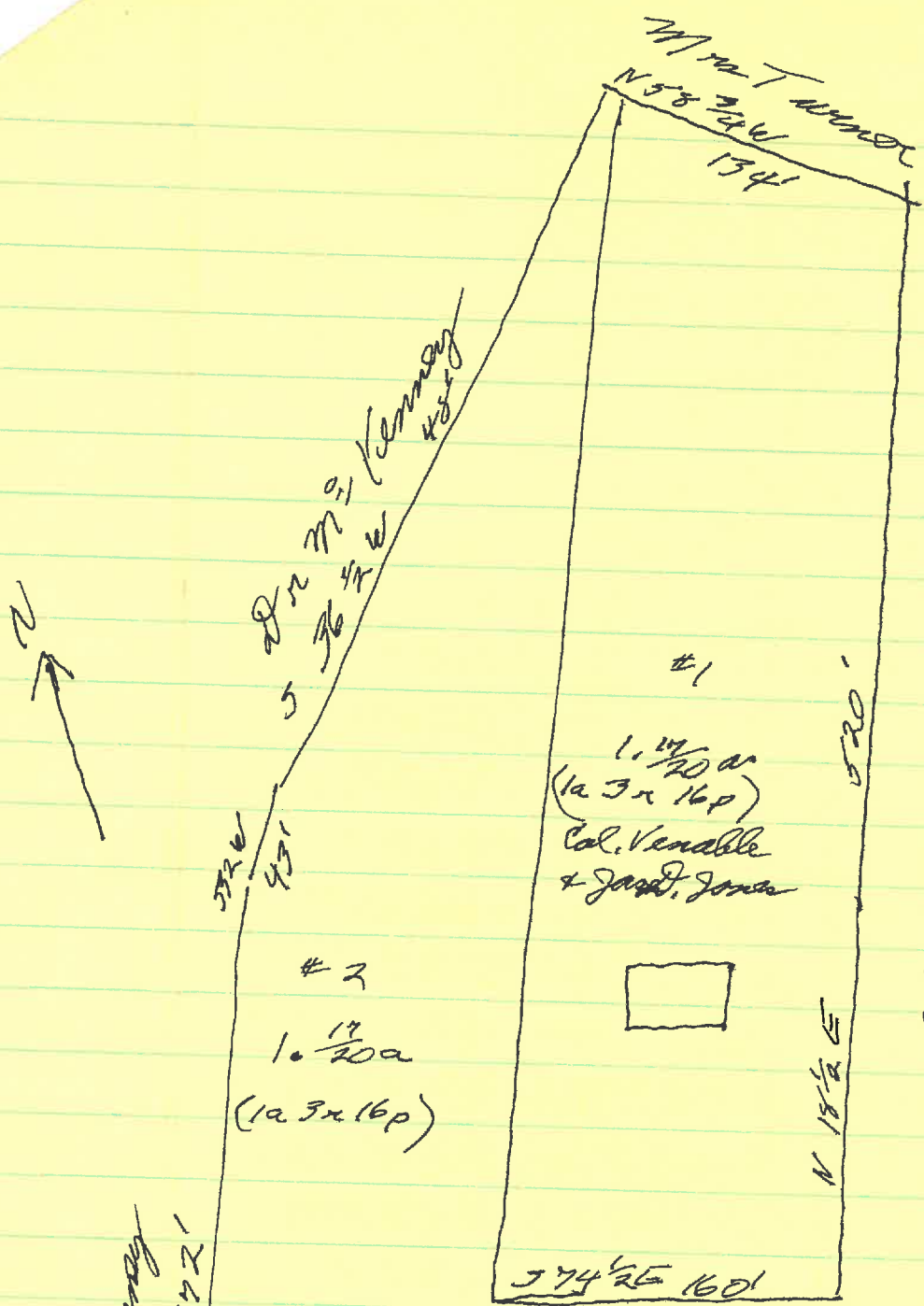

C. C. Wertenbaker

Mrs. Julian Harrison

Collier's estate

street

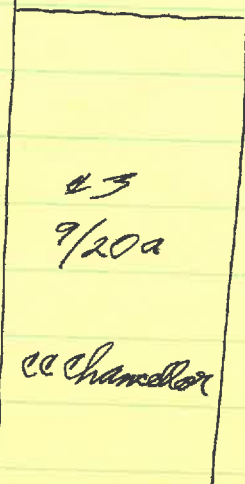

Mrs Hattie M Kenney

Univ. Ave.

$$\begin{array}{r}
 1 \quad 17/20 \\
 1 \quad 17/20 \\
 \quad \quad 9/20 \\
 \hline
 2 \quad 43/20 = 4 \frac{3}{20} \text{ acres}
 \end{array}$$

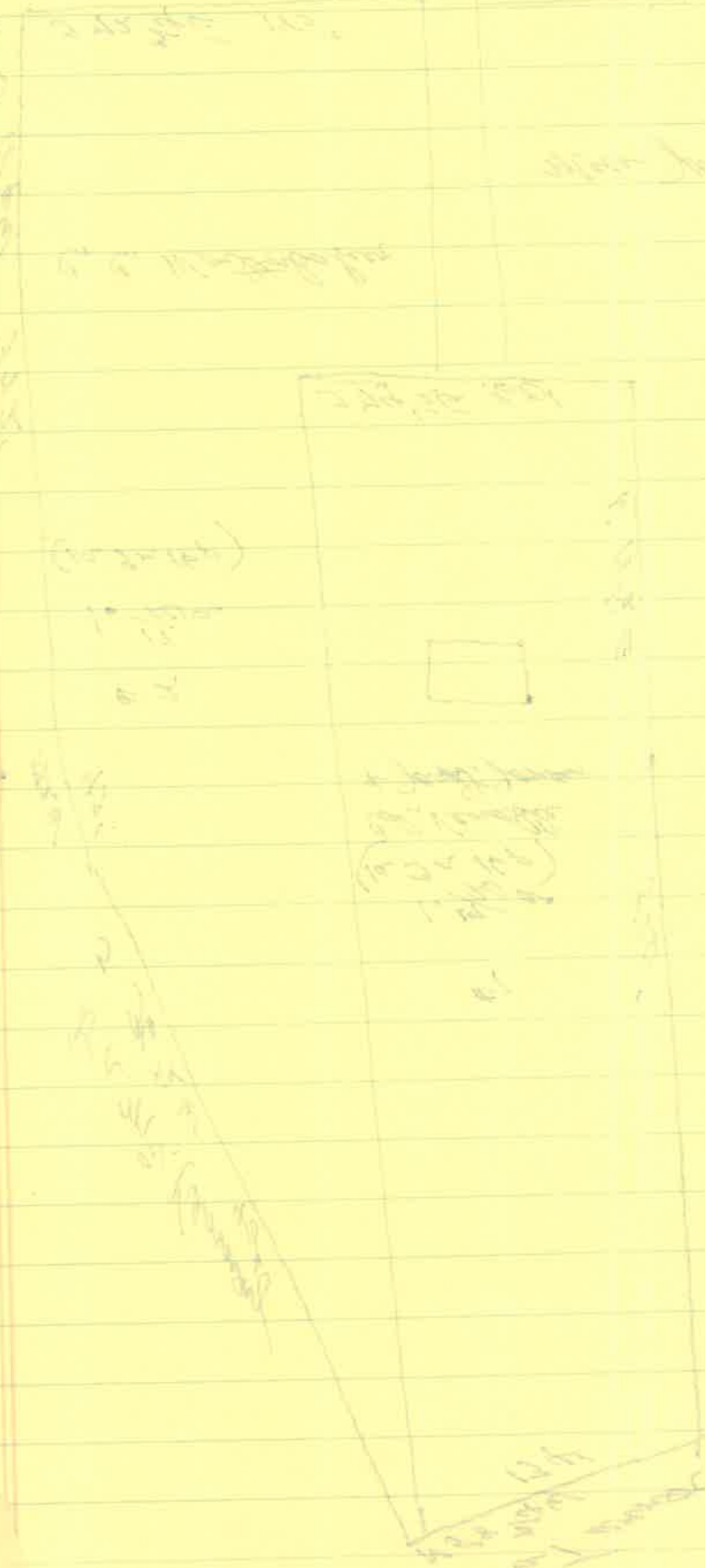
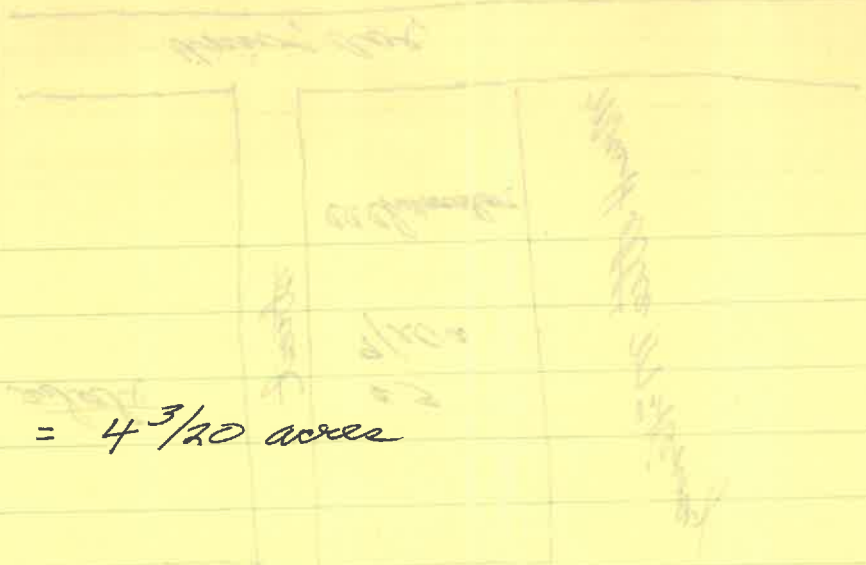

SW

1/2 mile  
1/2 mile  
1/2 mile

Wootenbaker

1836, 37, 38 John Dinmore 28 1/2 a 1/2 W Ch'co + 1337.50 = 2310.17  
 " Jas " ed 31a + 200 = 309  
 1838 " " " " 1W " + - = "

15500 off  
 to JAGD

1842 John Dinmore ed 30 a 1/2 W + 1500 = 2539  
 1843 " " " "

1842, 43 Wm Wootenbaker 3/4 a 1 NW + 500 = 525  
 1843 " " 6/4 a 4W + 2000 = 2812

for Jno Dinmore ed  
 1/2 7 21 1/2 13 1/2 7 1/2  
 \$2000 added for survey

## Wertenbaker

steep gable roof, proj eaves + cornice, cornice of  
returns, pl fringe, simple brackets

int end chim

Flem facade, 5-c dm found, 5-c dm - of Flem

E. W. rear

all wind 6/6, ~~moulded trim~~, shorter end &  
base,

ent; 3 horiz/3 vert panels; moulded pillars but  
carry cornice; dec ~~is~~ sidelights + base,  
corner lights closed

bracketed

Eastlake (turned) posts, pierced fringe,  
proj eaves, cornice,

very high Eng. base,

rear 5-c dm - of Flem sides, rear, found.

4

int chim

cornice + wind match  
roof low-pitched hips.



narrow cent hall  
2-fl dog-leg stair w/ single Fed bal  
dex, wall  
arch, trim, 6-panel doors  
fireplaces have coal grates

444-356	Wootenbaker Assoc	1983
442-204	The First Service Corp of SC,	"
WB 25-84		1981
<del>442-20</del>		



14704  
14705

Date 3.1996 File No. 104-47

Name Wentunbaker House

Town (1301 Westland St.)

County Clarke County

Photographer Dan Pezzoni

Contents 4 ext. views



## **Certificate of Appropriateness**

BAR # 22-10-02

101 East Jefferson Street, TMP 330190000

North Downtown ADC District (contributing)

Owner: First United Methodist Church

Applicant: William L. Owens, AIA

Project: FUMC solar panels

Application components (please click each link to go directly to PDF page):

- [Staff Report](#)
- [Historic Survey](#)
- [Application Submittal](#)

**City of Charlottesville  
Board of Architectural Review  
Staff Memo  
January 18, 2023**



**Certificate of Appropriateness**

BAR # 22-10-02

101 East Jefferson Street, TMP 330190000

North Downtown ADC District (contributing)

Owner: First United Methodist Church

Applicant: William L. Owens, AIA

Project: Install solar panels

---



**Background**

*Year Built:* 1923

*District:* North Downtown ADC District

*Status:* Contributing

First United Methodist Church is a Colonial Revival, brick church with a monumental portico and four Doric columns, with a tower and steeple.

**Prior BAR Actions** (See appendix for complete list)

September 20, 2022: Informal discussion, staff questions re: proposed solar panels.

Meeting video (04:41:00): [BAR Meeting Video Sept 20 2022](#)

October 18, 2022: Motion to approve solar panels (BAR #22-10-02) failed, 2-4. BAR accepted applicant's request for deferral.

Meeting video (02:06:00): [BAR Meeting Video Oct 18 2022](#)

Submittal: [101 East Jefferson Street - BAR Submittal Oct 2022](#)

**Application**

- Submittal: Wm. L Owens Architect, First United Methodist Church Solar Panel Project, dated December 27, 2022: Narrative, photos, and product specs (29 pages).

Request CoA for installation of roof-top solar panels.

- Where solar panels are to be installed, the existing slate shingles will be removed, and replaced by asphalt shingles over waterproof underlayment. Salvageable slate will be stored for repairs on remaining slate roofs or for re-installation, if considered later. [Staff Note on the existing roof: Buckingham slate. Original to building, 1923. Life cycle of Buckingham slate can exceed 150 years.]

- All electrical connections will be made in the attic or the basement. The only exposed equipment, other than the solar panels, will be a 2” conduit running from the backside of the array on the west facing roof, along the roofline at the east face of the steeple, and down the north face of the steeple to the existing electrical service at ground level in the courtyard. The conduit will be painted to match the existing slate or brick.
- The solar panels [on the mountain rails] will be no greater than 6” above the roof.

Approx. routing: 2” conduit.

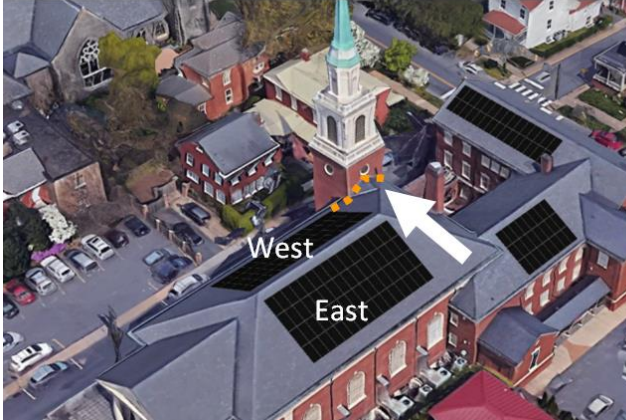

## **Discussion**

### **Initial request: Install panels onto existing slate roof**

At the September 20, 2022 meeting, staff asked the BAR for informal comments on this pending request, with the following offered:

- BAR Questions:
  - How will the panels be installed/mounted? (Brackets, hardware, etc.)
  - Where will wires/cables/conduit and equipment boxes be placed and how will they be screened, of necessary?
  - How high will the panels be above the slate?
  - How will the slate roof be protected during installation and subsequent maintenance of the solar panels? (Concern for condition of slate tiles with more-frequent activity.)
  - Photo-sim: panels on sanctuary are oriented NW.
- BAR Comments:
  - Preference: install panels on rear addition; avoid panels on sanctuary.
  - Re: maximizing panel area, a frame over the parking area (east side) might be evaluated.

### **Current request: Install panels onto asphalt shingles**

The BAR’s primary concern has been how the slate roof will be impacted by the activity related to the installation and maintenance of the solar panels. The applicant’s proposal resolves that concern.

Like the City of Charlottesville,<sup>1</sup> the FUMC congregation has made a commitment to support renewable energy. The ADC District design guidelines are somewhat silent on--if not in opposition to—externally adapting historic structures to accommodate on-site alternative and renewable energy sources. The guidelines do encourage *sustainability* and *green building*. However, they refer to

<sup>1</sup> Charlottesville Climate Action Plan: Strategies and Key Actions for Reducing Greenhouse Gas Emissions in Our Community, November 2022 Link: [Charlottesville-Climate-Action-Plan Nov 2022](#)

*solar* [collectors] only once—in discouraging them on historic roofs--there is no mention of *photovoltaic*, *alternative*, or *renewable* [energy]. Regardless, the urgency to act has increased exponentially since the guidelines were adopted.

Term	Times Used
<b>Sustainable / Sustainability</b>	18
<b>Green Building</b>	6
<b>Solar</b>	1
<b>Photovoltaic / Alternative / Renewable [Energy]</b>	0

While not emphasized in the design guidelines, the City’s Comprehensive Plan, adopted in 2021, specifically recommends expanding opportunity for solar power, see below. [Staff note: The Comp Plan refers to *residential homes* and *municipal buildings*; however, staff is comfortable interpreting this as a *City-wide* goal.]

From the five guiding principles [emphasis added]: The City government will reduce its carbon footprint and other environmental impacts. The Charlottesville community will be empowered and encouraged to reduce their environmental footprint and benefit from energy efficiency efforts. All will have access to high-quality natural resources, including improved air, soil, and water quality.

From Chapter 4: Strategy 3.4 Encourage sustainable, energy efficient building designs and low impact development as complementary goals to historic preservation, including through support for adaptation, reuse, and repurposing of the built environment.

- Sub-strategies:
  - Continue evaluating recommendations appropriate for historic structure improvements that increase energy efficiency and promote sustainability. Incorporate [the above] into the design guidelines for Architectural Design Control Districts, Individually Protected Properties, Historic Conservation Districts, and Entrance Corridor Overlay Districts.
  - Support the implementation of solar photovoltaic systems for historic structures.
  - Consider applying the Secretary of the Interior Standards for Historic Rehabilitation to all City-owned property more than 50 years old, and apply appropriate preservation technologies in all additions and alterations, while also pursuing sustainability and energy conservation goals.

From Chapter 7: Strategy 1.5: Pursue use of cleaner sources of energy (e.g., renewable energy strategies) community-wide.

- Sub-strategies:
  - Consider local policies and incentives to expand solar power in residential homes.
  - Pursue siting solar power on appropriate municipal buildings.

From the design guidelines, Chapter I - *Introduction*:

- *Nothing in these guidelines should be construed to discourage green building or sustainable design. If such a design is found to conflict with a specific guideline, the BAR shall work with*

*the applicant to devise a creative solution that meets that applicant's goal for sustainability that is also compatible with the character of the district and the property.*

- *The guidelines are flexible enough to both respect the historic past and to embrace the future.*

### **Staff Recommendations**

To be clear, a strict application of the design guidelines and of the Secretary's Standards would recommend denial of this request. With that, the options available to the BAR are: a) approve the CoA by, as instructed by the design guidelines, working *with the applicant to devise a creative solution that meets that applicant's goal for sustainability*; or, b) deny the CoA, acknowledging the matter can be appealed to City Council who *may consider additional information, factors or opinions deem[ed] relevant to the [appeal]*. (That is, Council may consider factors the BAR cannot.)

In choosing an option, staff suggests the BAR consider including guidance from the Comp Plan policy re: climate change and our environment. The following questions might be helpful--not to defer to obvious responses, but to establish context in considering how much flexibility the guidelines allow.

- Do the design guidelines and the Secretary's Standards express a clear, unambiguous direction?
- *Reversibility*: Are the impacts of the proposed work reversible?
- What guidance is offered in the City's Comprehensive Plan and how should they be used, if at all?
- In the pending updates to the design guidelines, would the BAR envision allowing or accommodating this and similar requests?
- If the existing roof was asphalt shingles—or if the slate was replaced with faux slate, which the BAR has allowed--how would this request be treated?
- Would approval establish an unacceptable, possibly unanticipated, precedent?

If the BAR approves the CoA, staff suggests the following conditions be considered:

- Slate shingles removed will be properly stored for later use on the building.
- If/when the solar panels are removed, the asphalt shingles will be replaced with either slate or a suitable faux-slate shingle.

### **Suggested Motions**

*Approval*: Having considered the standards set forth within the City Code, including the ADC District Design Guidelines, I move to find the proposed slate roof replacement and roof-top solar panels at 101 East Jefferson Street satisfies the BAR's criteria and is compatible with this property and other properties in the North Downtown ADC District, and that the BAR approves the application [as submitted].

Or, [... as submitted] with the following conditions:

*Denial*: Having considered the standards set forth within the City Code, including the ADC District Design Guidelines, I move to find that the proposed slate roof replacement and roof-top solar panels at 101 East Jefferson Street do not satisfy the BAR's criteria and are not compatible with this property and other properties in the North Downtown ADC District, and that for the following reasons the BAR denies the application as submitted:

## **Criteria, Standards and Guidelines**

### **Review Criteria Generally**

Sec. 34-284(b) of the City Code states that, In considering a particular application the BAR shall approve the application unless it finds:

- (1) That the proposal does not meet specific standards set forth within this division or applicable provisions of the Design Guidelines established by the board pursuant to Sec. 34-288(6); and
- (2) The proposal is incompatible with the historic, cultural or architectural character of the district in which the property is located or the protected property that is the subject of the application.

### **Pertinent Standards for Review of Construction and Alterations include:**

- (1) Whether the material, texture, color, height, scale, mass and placement of the proposed addition, modification or construction are visually and architecturally compatible with the site and the applicable design control district;
- (2) The harmony of the proposed change in terms of overall proportion and the size and placement of entrances, windows, awnings, exterior stairs and signs;
- (3) The Secretary of the Interior Standards for Rehabilitation set forth within the Code of Federal Regulations (36 C.F.R. §67.7(b)), as may be relevant;
- (4) The effect of the proposed change on the historic district neighborhood;
- (5) The impact of the proposed change on other protected features on the property, such as gardens, landscaping, fences, walls and walks;
- (6) Whether the proposed method of construction, renovation or restoration could have an adverse impact on the structure or site, or adjacent buildings or structures;
- (7) Any applicable provisions of the City's Design Guidelines.

### **Pertinent Guidelines from Chapter I – Introduction**

Link: [Chapter 1 Introduction \(Part 1\)](#)

*Sustainability:* Sustainability and preservation are complementary concepts, and both goals should be pursued. **Nothing in these guidelines should be construed to discourage green building or sustainable design. If such a design is found to conflict with a specific guideline, the BAR shall work with the applicant to devise a creative solution that meets that applicant's goal for sustainability that is also compatible with the character of the district and the property.**

*Flexibility:* The following guidelines offer general recommendations on the design for all new buildings and additions in Charlottesville's historic districts. **The guidelines are flexible enough to both respect the historic past and to embrace the future.** The intent of these guidelines is not to be overly specific or to dictate certain designs to owners and designers. The intent is also not to encourage copying or mimicking particular historic styles. These guidelines are intended to provide a general design framework for new construction. Designers can take cues from the traditional architecture of the area and have the freedom to design appropriate new architecture for Charlottesville's historic districts.

### **Pertinent Guidelines from Chapter IV - Rehabilitation**

Link: [Chapter 4 Rehabilitation](#)

#### **G. Roof**

- 1) When replacing a standing seam metal roof, the width of the pan and the seam height should be consistent with the original. Ideally, the seams would be hand crimped.



- 2) If pre-painted standing seam metal roof material is permitted, commercial-looking ridge caps or ridge vents are not appropriate on residential structures.
- 3) Original roof pitch and configuration should be maintained.
- 4) The original size and shape of dormers should be maintained.
- 5) Dormers should not be introduced on visible elevations where none existed originally.
- 6) Retain elements, such as chimneys, skylights, and light wells that contribute to the style and character of the building.
- 7) When replacing a roof, match original materials as closely as possible.
  - a. Avoid, for example, replacing a standing-seam metal roof with asphalt shingles, as this would dramatically alter the building's appearance.
  - b. Artificial slate is an acceptable substitute when replacement is needed.
  - c. Do not change the appearance or material of parapet coping.
- 8) Place solar collectors and antennae on non-character defining roofs or roofs of non-historic adjacent buildings.
- 9) Do not add new elements, such as vents, skylights, or additional stories that would be visible on the primary elevations of the building.

### **Pertinent Guidelines from the Secretary's Standards**

1. A property shall be used for its historic purpose or be placed in a new use that requires minimal change to the defining characteristics of the building and its site and environment.
2. The historic character of a property shall be retained and preserved. The removal of historic materials or alteration of features and spaces that characterize a property shall be avoided.
3. Each property shall be recognized as a physical record of its time, place, and use. Changes that create a false sense of historical development, such as adding conjectural features or architectural elements from other buildings, shall not be undertaken.
4. Most properties change over time; those changes that have acquired historic significance in their own right shall be retained and preserved.
5. Distinctive features, finishes, and construction techniques or examples of craftsmanship that characterize a historic property shall be preserved.
6. Deteriorated historic features shall be repaired rather than replaced. Where the severity of deterioration requires replacement of a distinctive feature, the new feature shall match the old in design, color, texture, and other visual qualities and, where possible, materials. Replacement of missing features shall be substantiated by documentary, physical, or pictorial evidence.
7. Chemical or physical treatments, such as sandblasting, that cause damage to historic materials shall not be used. The surface cleaning of structures, if appropriate, shall be undertaken using the gentlest means possible.
8. Significant archeological resources affected by a project shall be protected and preserved. If such resources must be disturbed, mitigation measures shall be undertaken.
9. New additions, exterior alterations, or related new construction shall not destroy historic materials that characterize the property. The new work shall be differentiated from the old and shall be compatible with the massing, size, scale, and architectural features to protect the historic integrity of the property and its environment.
10. New additions and adjacent or related new construction shall be undertaken in such a manner that if removed in the future, the essential form and integrity of the historic property and its environment would be unimpaired.

### **Building Exterior – Roofs: Alterations/Additions for the New Use**

#### **Recommended:**

Installing mechanical and service equipment on the roof such as air conditioning, transformers, or solar collectors when required for the new use so that they are inconspicuous from the public right-of-way and do not damage or obscure character defining features.

Designing additions to roofs such as residential, office, or storage spaces; elevator housing; decks and terraces; or dormers or skylights when required by the new use so that they are inconspicuous from the public right-of-way and do not damage or obscure character-defining features.

Not Recommended:

Installing mechanical or service equipment so that it damages or obscures character-defining features; or is conspicuous from the public right-of-way.

Radically changing a character-defining roof shape or damaging or destroying character-defining roofing material as a result of incompatible design or improper installation techniques.

Energy Conservation - Roofs

Recommended:

Placing solar collectors on non-character-defining roofs or roofs of non-historic adjacent buildings.

Not Recommended:

Placing solar collectors on roofs when such collectors change the historic roofline or obscure the relationship of the roof features such as dormers, skylights, and chimneys.

*The Secretary of the Interior's Standards for Rehabilitation & Illustrated Guidelines on Sustainability for Rehabilitating Historic Building*

<https://www.nps.gov/orgs/1739/upload/sustainability-guidelines.pdf>

Pages 14 and 15

Solar Technology

Recommended:

- Considering on-site, solar technology only after implementing all appropriate treatments to improve energy efficiency of the building, which often have greater life-cycle cost benefit than on-site renewable energy.
- Analyzing whether solar technology can be used successfully and will benefit a historic building without compromising its character or the character of the site or the surrounding historic district.
- Installing a solar device in a compatible location on the site or on a non-historic building or addition where it will have minimal impact on the historic building and its site.
- Installing a solar device on the historic building only after other locations have been investigated and determined infeasible.
- Installing a low-profile solar device on the historic building so that it is not visible or only minimally visible from the public right of way: for example, on a flat roof and set back to take advantage of a parapet or other roof feature to screen solar panels from view; or on a secondary slope of a roof, out of view from the public right of way.

- Installing a solar device on the historic building in a manner that does not damage historic roofing material or negatively impact the building’s historic character and is reversible.
- Installing solar roof panels horizontally – flat or parallel to the roof—to reduce visibility

Not Recommended:

- Installing on-site, solar technology without first implementing all appropriate treatments to the building to improve its energy efficiency.
- Installing a solar device without first analyzing its potential benefit or whether it will negatively impact the character of the historic building or site or the surrounding historic district.
- Placing a solar device in a highly-visible location where it will negatively impact the historic building and its site.
- Installing a solar device on the historic building without first considering other locations.
- Installing a solar device in a prominent location on the building where it will negatively impact its historic character.
- Installing a solar device on the historic building in a manner that damages historic roofing material or replaces it with an incompatible material and is not reversible.
- Removing historic roof features to install solar panels.
- Altering a historic, character-defining roof slope to install solar panels.
- Installing solar devices that are not reversible.
- Placing solar roof panels vertically where they are highly visible and will negatively impact the historic character of the building.

**APPENDIX**

Prior BAR Actions re; 101 East Jefferson Street

- February 17, 2004 – Preliminary discussion re: iron fencing.
- April 20, 2004 – BAR approved the addition of a five-ft high, wrought iron fence parallel to the east property line to protect the public from a large window well.
- March 15, 2011 – BAR approved (7-0) modifications to/replacement of main entry doors as submitted with conditions: (a) door be replaced, not modified, with existing doors saved/stored on site; and (b) glass in the new door is clear glass, not beveled glass.
- June 21, 2011 – BAR approved (6-0) a new bathroom addition as submitted.
- October 18, 2016 – BAR approved (8-0) steeple lighting. (BAR awarded a *2020 Preservation and Design Award*: Rehabilitation of Historic Steeple and Installation of Steeple Illumination.)

Solar panel installations reviewed by BAR since 2010. All were approved.

Since 2010, the BAR has reviewed 15 projects with solar panel arrays, all were approved. (See list in the Appendix.) Since adoption of the current design guidelines, the BAR has reviewed and approved 11 CoA requests for photovoltaic panels--eight in ADC Districts and three in HC Districts. All, except one, were rooftop arrays.

The design guidelines for Rehabilitation do not specifically recommend against solar panels on historic roofs; instead recommending they be placed *on non-character defining roofs or roofs of non-historic adjacent buildings*. In the BAR staff reports for several projects reviewed between 2010 and 2017, the Preservation and Design Planner applied the following when recommending approval: *The panels extend up from the roof by less than one foot, which does not significantly change the profile of the roofline*. This appears to be an interpretation of a recommendation in the Secretary’s Standards to not place panels *where they will change the historic roofline or obscure the relationship of the roof features such as dormers, skylights, and chimneys*. That is, panels that are installed low and parallel to the roof surface will not change the profile of the roofline.

<b>Date</b>	<b>Address</b>	<b>District</b>	<b>Roof type (location of panels)</b>
Apr-10	215 East High St	North Downtown	parapet (not visible)
Aug-10	222 South St	Downtown	frame in back yard (rear)
Oct-10	219 14th St NW	Rugby-U Circle-Venable	standing-seam metal (side)
Mar-12	230 West Main St	Downtown	parapet (not visible)
Oct-16	206 West Market St	Downtown	parapet (not visible)
Aug-16	450 Rugby Rd	Rugby-U Circle-Venable	flat roof (rear)
May-17	615 Lexington Ave	Martha Jeff HC	standing-seam metal (rear)
Jul-18	503 Lexington Ave	Martha Jeff HC	standing-seam metal (side)
Apr-19	1102 Carlton Ave	IPP	standing-seam metal (rear)
Aug-19	507 Ridge St	Ridge Street	frame in back yard (rear)
Mar-19	206 5th St NE	North Downtown	membrane (rear)
Mar-19	420 Park St	North Downtown	standing-seam metal (side and rear)
Mar-19	924 Rugby Rd	Rugby Road HC	standing-seam metal (front and rear)
Aug-21	735 Northwood Ave	North Downtown	standing-seam metal (front)
Jun-22	636 Park St	North Downtown	standing-seam metal (rear)

Etc.

During the 2018-2020 [pre-COVID] discussions re: updating the design guidelines, staff noted the following BAR comments related to solar panels:

Chapter III – *Rehabilitation*. Roof:

- Should not damage or interfere with historic material.
- If existing roof is relatively flat, panels should not create the illusion of a sloped roof.
- Advise owners to inspect condition of existing roof prior to attaching solar equipment; make necessary repairs—even replacement—prior to installing solar equipment.
- Address/evaluate photovoltaic shingles as replacement shingles.
- Address/evaluate how panels are attached to historic roofs.



## **FIRST UNITED METHODIST CHURCH Solar Panel Project**

December 27, 2022

### **Description of Proposed Work**

As part of green initiatives currently ongoing at the church, the congregation of First United Methodist Church (101 East Jefferson Street) wishes to consider adding solar panel arrays on several of the church building's roof surfaces. The church has received a promise of a large donation to seed the project and will fund the remaining cost through matching donations and the Federal tax credit now available to nonprofits as part of the Inflation Reduction Act of 2022.

The goal of the project is to reduce the church's demand for electrical service as much as possible through being supportive of renewable energy and demonstrating good stewardship of the environment. In order to accomplish this goal, the church wishes to maximizing the coverage of solar panels as much as practicable. As proposed, (see attached photo simulations) the church's electrical costs would be reduced by approximately 50% at a savings of about \$11,000 per year.

Following the presentation of the project concept to the BAR in October, the church met with its roofer and solar provider to reevaluate the project's approach, particularly to installation, since the mounting of the solar panels through the existing 100-year-old slate shingle roof was a major topic of concern at the meeting. The church now proposes to remove the slate shingles under the solar arrays and replace them with a waterproofing underlayment and dark colored asphalt shingles. This will allow for a more typical installation of the panels by the solar provider (see attached product information) and reduce the maintenance concerns for the church associated with a slate roof installation.

The existing slate tiles that are replaced for asphalt shingles will be salvaged and used to repair any damage to the exposed roof during installation or stored by the church for possible restoration if the solar panels are removed in the future. In addition, the roofer has found a source for new slate shingles that matches the original Buckingham Slate tiles, also for use in any required repair or future replacement.

Since the solar panels sit parallel to and only 6" above the roof surface, and project 12"-24" beyond the mounting rails, the asphalt shingles will not be visible, even when standing on the roof itself. The geometry of the arrays has been revised to a regular rectangular shape from the stepped geometry previously proposed to simplify the new roof installation and more easily disguise the asphalt shingles. All roof areas not covered by solar panels will remain visible as the existing slate shingles.

The solar panel arrays themselves will not be viewable on the church roofs from the surrounding block (see attached site photos) and only seen from the church parking lot and at a significant distance. Since the panels are mounted close to and matching the existing roof slopes, they should not be considered as changing the historic roofline or altering the character defining features of the church.

# First United Methodist Church

## Solar Panel Project

### Photo Simulation 1



# First United Methodist Church

## Solar Panel Project

### Photo Simulation 2



# First United Methodist Church

## Solar Panel Project

### Photo Simulation 3





# First United Methodist Church Solar Panel Project

## Site Photos – East Jefferson Street



Property from E. Jefferson St./1<sup>st</sup> St. N. Intersection



Property from E. Jefferson St./2<sup>nd</sup> St. N.E. Intersection



Facing Property from E. Jefferson St.



Facing Property from E. Jefferson St.

# First United Methodist Church Solar Panel Project

## Site Photos – 1<sup>st</sup> Street N.



Property from E. High St./1<sup>st</sup> St. N. Intersection



Property from E. Jefferson St./1<sup>st</sup> St. N. Intersection



Facing Properties from E. Jefferson St./1<sup>st</sup> St. N. Intersection



Facing Properties from E. High St./1<sup>st</sup> St. N. Intersection

# First United Methodist Church Solar Panel Project

## Site Photos – 2<sup>nd</sup> Street N.E.



Neighboring Property from 2<sup>nd</sup> Street N.E.



Property from 2<sup>nd</sup> Street N.E.



Facing Property from E. High St./2<sup>nd</sup> St. N.E. Intersection



Facing Property from E. Jefferson St./2<sup>nd</sup> St. N.E. Intersection

# First United Methodist Church Solar Panel Project

## Site Photos – E. High Street



Property from E. High St./2<sup>nd</sup> St. N.E. Intersection



Property from E. High St./1<sup>st</sup> St. N. Intersection



Facing Properties from E. High St./1<sup>st</sup> St. N. Intersection



Facing Properties from E. High St./2<sup>nd</sup> St. N.E. Intersection

## Moving Flashing Forward

We set out to design a flashing that checked all the boxes: fully waterproof, fast and easy to install correctly, economical, and strong enough to handle every environmental condition. FlashVue® does it all.

The optimized flashing design features a large viewport, for easy alignment with the pilot hole. And the GripCap® and GripCap+® sit snugly in place, so the lag can be driven single-handedly.

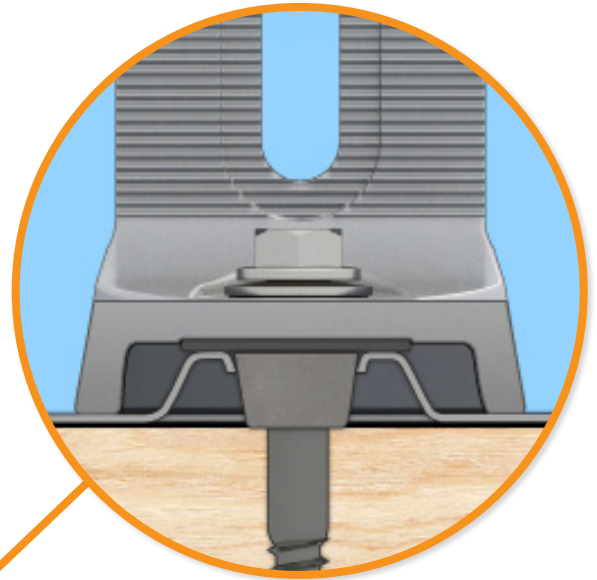

### Three-Tier Water Seal, Reimagined

FlashVue®'s seal architecture utilizes three layers of protection. The viewport is elevated 0.30", and provides a "friction-fit" for the GripCap®. The GripCap® fully covers the viewport while a sealing washer adds another layer of protection. And an EPDM washer and lag bolt "seal the deal" in the

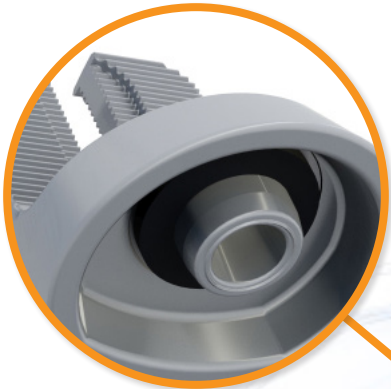

### GripCap® & GripCap+®

The 360° capable GripCap® (2.74" tall) and GripCap+® (3.74" tall) can be placed in any orientation, and provide a "friction-fit" for easy installs. Push snug into the viewport, without worrying it will roll away or rotate while driving the lag.

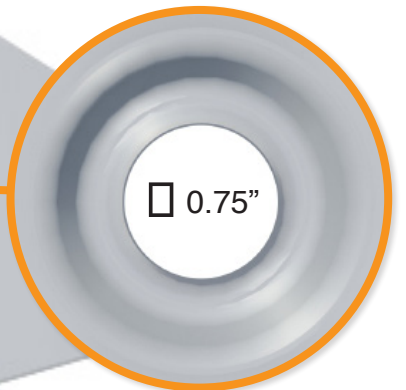

### Large Viewport in Flashing

The large viewport makes it easy to align the flashing with the pilot hole, and drive the lag centered into the rafter. The elevated rim not only provides a sturdy dock for the GripCap® or GripCap+®, but increases water-shedding



Triple Certified to Protect the Roof™

UL 2703, 441 (27)  
TAS 100(A)-95



## See Your Pilot Holes

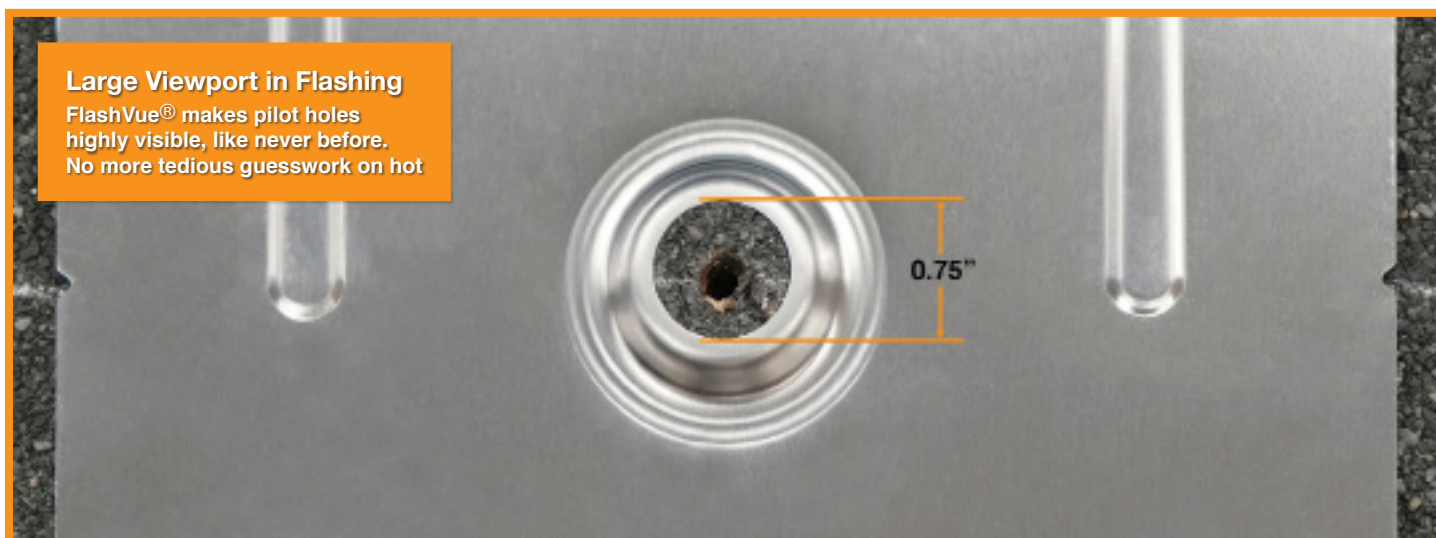

## Solve Roof Undulations

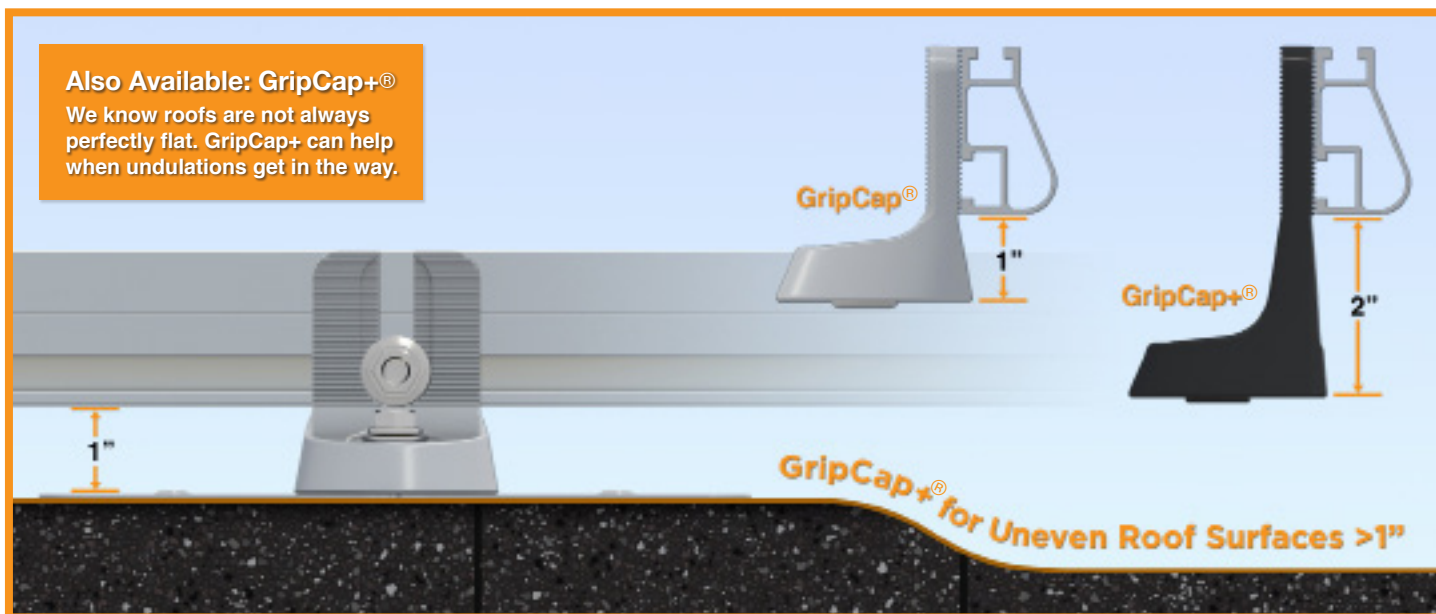

## Trusted Strength & Certification

### Attachment Loading

FlashVue® has been tested and rated to support 1161 (lbs) of uplift and 353 (lbs) of lateral load.

### Structural Certification

Designed and certified for compliance with the International Building Code & ASCE/SEI-7.

### Water Seal Ratings

Passed both the UL 441 Section 27 "Rain Test" and TAS 100-95 "Wind Driven Rain Test" by Intertek.

### UL 2703 Listed System

Conforms to UL 2703 mechanical and bonding requirements. See Flush Mount Manual for more info.

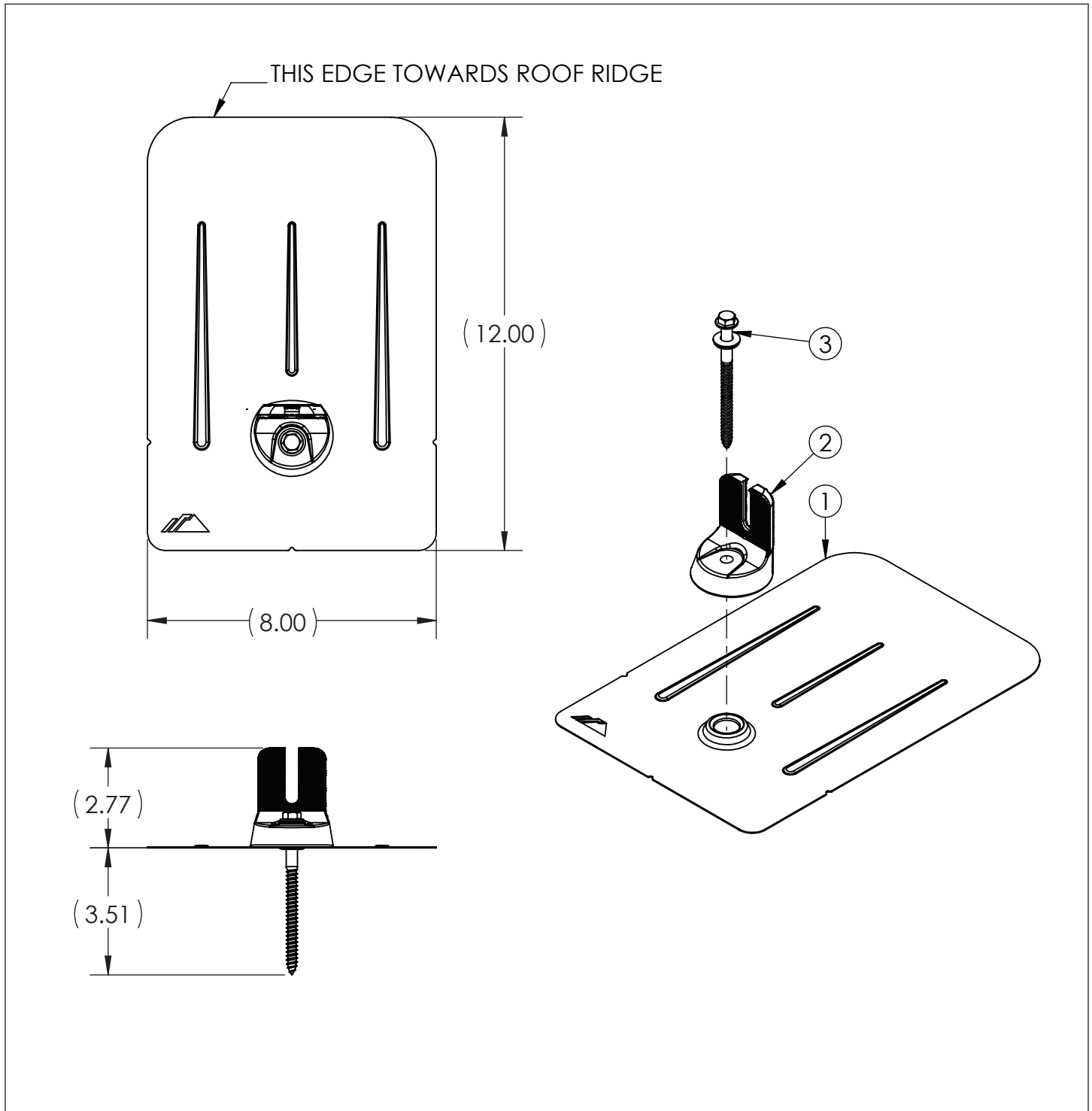

ITEM NO.	DESCRIPTION
1	FM FLASHING, MILL OR <b>BLACK</b>
2	GRIP CAP, MILL OR <b>BLACK</b>
3	LAG & BONDED WASHER, 5/16 X 4.25, 7/16 HEX HEAD

<b>FLASHVUE®</b>		
SIZE <b>A</b>	DO NOT SCALE DRAWING	
SCALE: 1:4	WEIGHT: 0.6 lbs	SHEET 1 OF 1

# Installation

Tools Required: tape measure, chalk, approved sealing materials, driver with 1/4" bit and 7/16" hex socket

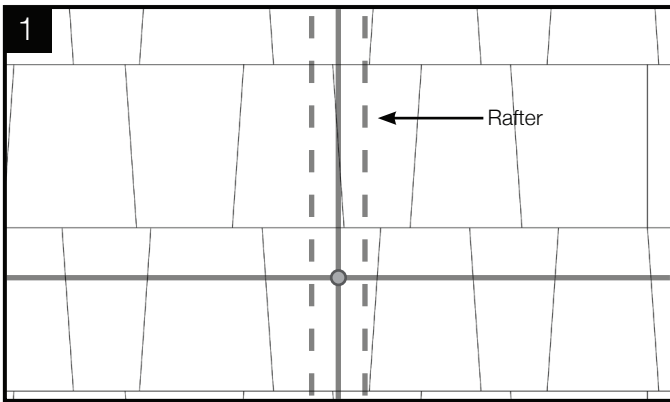

Locate rafters and snap vertical and horizontal lines to mark locations of flashings. Drill 1/4" pilot holes, then fill with roofing manufacturer's approved sealant.

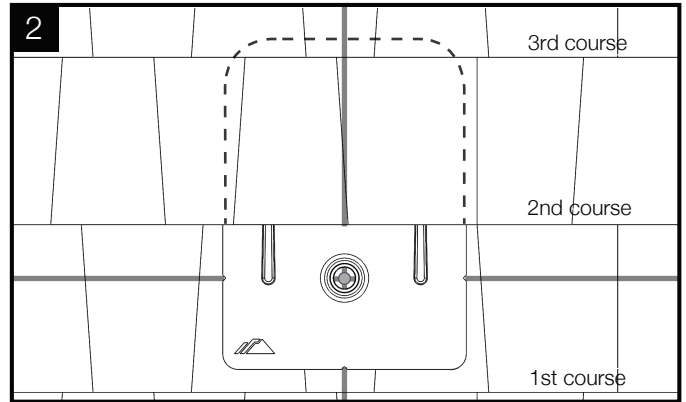

Slide flashing between 1st and 2nd course, so the top is at least 3/4" above the edge of the 3rd course and the bottom is above the edge of the 1st course. Line up pilot hole with view port.

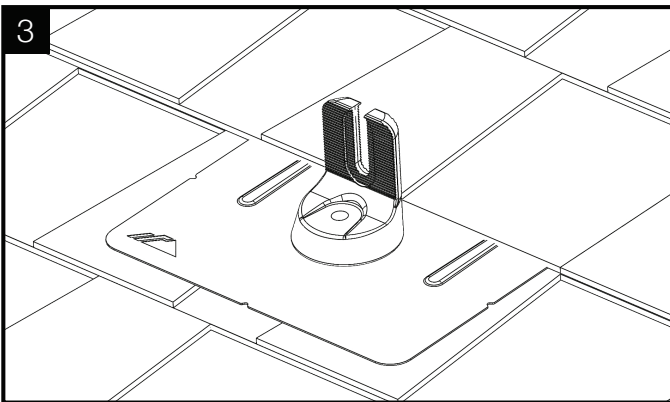

Press Grip Cap onto flashing in desired orientation for E/W or N/S rails.

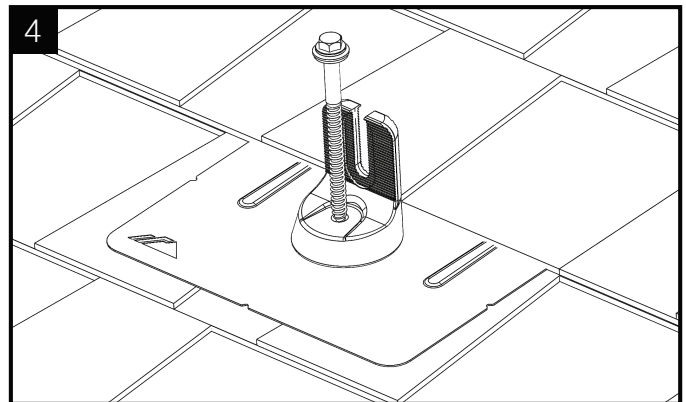

Insert lag bolt with EPDM backed washer through flashing. Tighten lag bolt until fully seated. FlashVue is now installed and ready for IronRidge XR Rails.

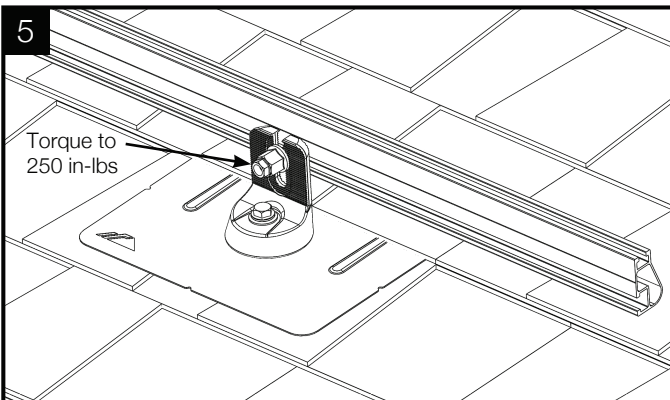

Attach rails to either side of the open slot using bonding hardware. Level rail at desired height, then torque to 250 in-lbs (21 ft-lbs).

## Structural Certification

Designed and Certified for Compliance with the International Building Code & ASCE/SEI-7.

## Water Seal Ratings

Water Sealing Tested to UL 441 Section 27 "Rain Test" and TAS 100(A)-95 "Wind Driven Rain Test" by Intertek. Tested and evaluated without sealant. Any roofing manufacturer approved sealant is allowed.

## UL 2703

Conforms to UL 2703 (2015) Mechanical and Bonding requirements. See Ironridge Flush Mount Installation Manual for full ratings.



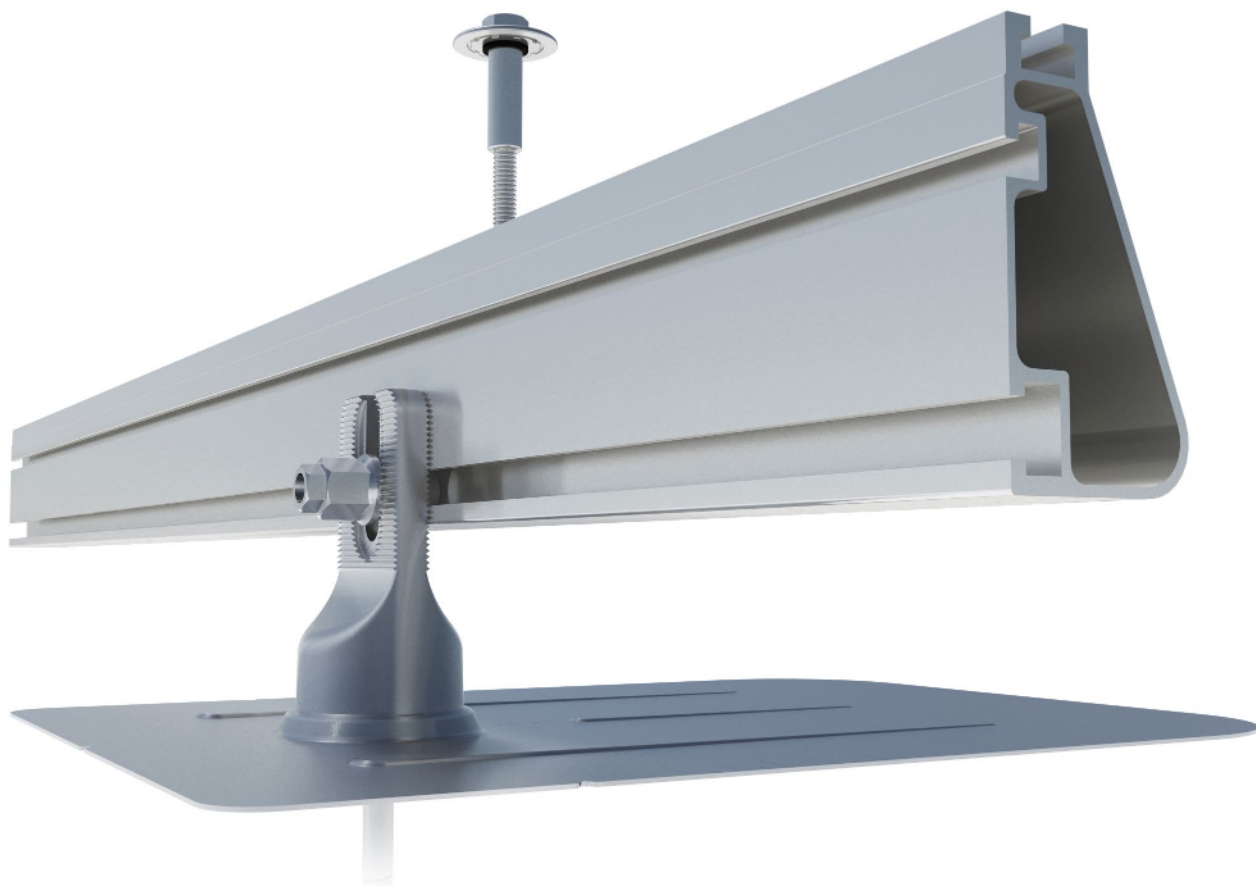

### Built for solar's toughest roofs.

IronRidge builds the strongest mounting system for pitched roofs in solar. Our components have been tested to the limit and proven in extreme environments, including Florida's high-velocity hurricane zones.

Our rigorous approach has led to unique structural features, such as curved rails and reinforced flashings, and is also why our products are fully certified, code compliant and backed by a 25-year warranty.



#### **Strength Tested**

All components evaluated for superior structural performance.



#### **PE Certified**

Pre-stamped engineering letters available in most states.



#### **Class A Fire Rating**

Certified to maintain the fire resistance rating of the existing roof.



#### **Design Assistant**

Online software makes it simple to create, share, and price projects.



#### **UL 2703 Listed System**

Entire system and components meet newest effective UL 2703 standard.



#### **25-Year Warranty**

Products guaranteed to be free of impairing defects.

**XR Rails** ☺

**XR10 Rail**



A low-profile mounting rail for regions with light snow.

- 6' spanning capability
- Moderate load capability
- Clear and black finish

**XR100 Rail**



The ultimate residential solar mounting rail.

- 8' spanning capability
- Heavy load capability
- Clear and black finish

**XR1000 Rail**

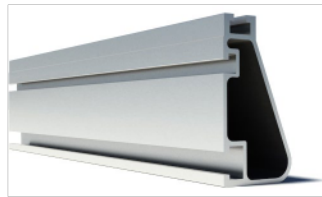

A heavyweight mounting rail for commercial projects.

- 12' spanning capability
- Extreme load capability
- Clear anodized finish

**BOSS™ Bonded Splices**



Bonded Structural Splices connect XR Rails together.

- Integrated bonding
- No tools or hardware
- Self-centering stop tab

**Clamps & Grounding** ☺

**UFO™**



Universal Fastening Objects bond modules to rails.

- Fully assembled & lubed
- Single, universal size
- Clear and black finish

**Stopper Sleeves**



Snap onto the UFO to turn into a bonded end clamp.

- Bonds modules to rails
- Sized to match modules
- Clear and black finish

**CAMO™**



Bond modules to rails while staying completely hidden.

- Universal end-cam clamp
- Tool-less installation
- Fully assembled

**Bonding Hardware**



Bond and attach XR Rails to roof attachments.

- T & Square Bolt options
- Nut uses 7/16" socket
- Assembled and lubricated

**Attachments** ☺

**FlashFoot2™**



Flash and mount XR Rails with superior waterproofing.

- Twist-on Cap eases install
- Wind-driven rain tested
- Mill and black finish

**FlashVue™**



Flash and mount conduit, strut, or junction boxes.

- Twist-on Cap eases install
- Wind-driven rain tested
- Secures 3/4" or 1" conduit

**Knockout Tile**



Replace tiles and ensure superior waterproofing.

- Flat, S, & W tile profiles
- Form-fit compression seal
- Single-lag universal base

**All Tile Hook**



Mount on tile roofs with a simple, adjustable hook.

- Works on flat, S, & W tiles
- Single-socket installation
- Optional deck flashing

**Resources**



**Design Assistant**

Go from rough layout to fully engineered system. For free.

**Go to [IronRidge.com/design](https://IronRidge.com/design)**



**Endorsed by FL Building Commission**

Flush Mount is the first mounting system to receive Florida Product approval for 2017 Florida Building Code compliance.

**Learn More at [bit.ly/floridacert](https://bit.ly/floridacert)**



# LANDMARK



# SURVEY

## IDENTIFICATION

Street Address: 101 East Jefferson Street  
 Map and Parcel: 33-190  
 Census Tract & Block: 1-107  
 Present Owner: First Methodist Church  
 Address: 101 East Jefferson Street  
 Present Use: Church  
 Original Owner: First Methodist Church  
 Original Use: Church

## BASE DATA

Historic Name: First Methodist Church  
 Date/Period: 1923-24  
 Style: Colonial Revival  
 Height to Cornice: 31  
 Height in Stories: 2  
 Present Zoning: B-1  
 Land Area (sq.ft.): 89 x 115  
 Assessed Value (land + imp.): 25,880 + 230,730 = 265,610

## ARCHITECTURAL DESCRIPTION

Colonial Revival Church with a monumental portico of four doric columns, entablature with triglyphs, and a broad pediment. One of the most unusual features of this church is its detached tower and steeple. The source for this arrangement is clearly Wren's church type, which he developed after the Great Fire of 1666. Other impressive features of this design include the flight of entrance steps which spill out well beyond the flanking terraces which are themselves inspired by those found on the Lawn of the University. The interior is painted to resemble ashlar masonry and is fitted with typical panelled woodwork. The architect for this church was Joseph Hudnut.

## HISTORICAL DESCRIPTION

The First Methodist Church bought the lot from R. S. J. Sterling in January of 1922. The \$20,000 purchase price included a residence appraised at \$2,200, which was removed to make room for the present structure. This site is the third to be occupied by the First Methodist Church. The earliest, built 1834-35, was situated on a lot bounded by Water, First, and South Streets. The second, begun in 1859, was finished in 1867, and was located on the corner of West Second and Water Streets.

## GRAPHICS



## CONDITIONS

Good

## SOURCES

Alexander's Recollections, 1963 editions.  
 City Records

A CENTURY OF METHODISM  
IN CHARLOTTESVILLE  
VIRGINIA

*By*  
A. L. BENNETT

A BRIEF ACCOUNT OF SOME OF THE MEN AND  
EVENTS CONNECTED WITH THE FIRST METH-  
ODIST EPISCOPAL CHURCH, SOUTH, OF  
CHARLOTTESVILLE, VIRGINIA

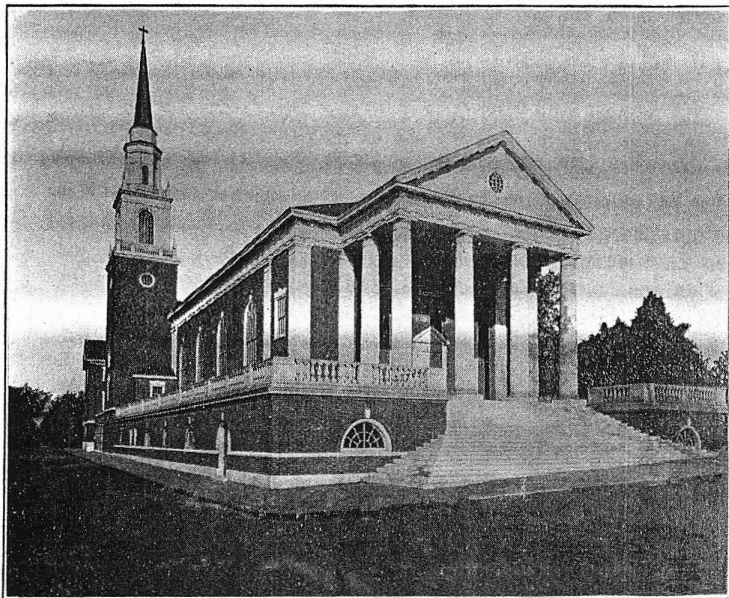

FIRST METHODIST EPISCOPAL CHURCH, SOUTH, CHARLOTTESVILLE, VA.

A Short History Prepared for the Centennial Celebration  
November 11-14, 1934.

Published by  
FIRST METHODIST EPISCOPAL CHURCH, SOUTH  
CHARLOTTESVILLE, VIRGINIA

1 9 3 4

*The first Meth. church in Ch'ville was a small*

*1st  
bldg.*

brick structure, built on the site now partly occupied by the old parsonage. It was built by James Lobbin, and had a seating capacity of about 350, including the gallery at the rear end. The very high pulpit, somewhat like that found in the old Episcopal churches, was used.

The lot on which the church stood was purchased in 1834, from Jesse Scott, a colored man, for \$150. Scott presented the church with \$10 of the purchase money. This was considered very cheap, even in that day. The trustees' names were Gessner Harrison, Nathan C. Goodman, Stapleton Sneed, Matthew and Thomas Wingfield, Ebenzer Watts and Thomas Price.

The lot (bounded by Water, First and South Streets) contained about half an acre and the church stood in the center, surrounded by a large yard. The entrance was on the north side, facing Water Street. The building was surmounted by a tower of peculiar structure which Dr. Hammet said resembled an inverted card table. This comment caused the legs of the "card table" promptly to be sawed off.

There was no organ in the church, public opinion being at that time against the use of instrumental music in the service, as shown by the fact that an old lady of a sister denomination left her church upon the introduction of the violin into the choir. Nevertheless the singing was hearty, and was considered an important part of the service.

The church was dedicated in 1835 by Bishop Emory. Edward Wadsworth was then pastor. Says the late Rev. James A. Riddick: "At the Conference of 1835 Rev. Edward Wadsworth was appointed to Charlottesville and Scottsville, with one church, Temple Hill, near Carter's Bridge, between. He alternated the Sabbaths between the two towns and preached at Temple Hill during the week. Wadsworth was a young man of great ability, and Methodism gained considerably that year in all his churches. Dr. Wm. Hammet was then chaplain at the University of Virginia and greatly assisted Jamison, the first pastor and Wadsworth in securing funds for the new church.

The next year Riddick says: "I was assigned to the same charge which Wadsworth had held. The moral and religious statue of the two towns was fairly good and the Sabbath was properly observed."

"In 1837 Charlottesville was made an independent sta-

tic  
m:  
re  
co  
Se  
Di  
th  
we  
no  
an  
my  
Hi  
ov

pe  
M:  
sh  
me  
co  
in  
ve

Ma  
we  
of  
wa

wit  
out  
wit

hav  
bet  
gro  
clo  
of  
The  
anc  
tion

free

CHAPTER THREE  
THE SECOND PERIOD

By the late fifties the congregation felt the need of a larger and better church. What we call the "old church"—the one located at the corner of Second and Water Streets and now used as a garage was begun under Dr. Judkins in 1859 but the work was interrupted by the War Between the States. The edifice was completed in 1866-67 while Thomas A. Ware was pastor. G. W. Spooner, a member of the church was the builder. Of the workmen on this building only one, George Nimmo, aged 84, is now living. The work done under the Ware pastorate cost \$3900. By 1887 under the pastorate of H. M. Hope the congregation decided to enlarge and remodel the church at a cost of \$7000.00. G. W. Spooner, the original builder and his son were the contractors. Another son, George, was the draftsman. He afterwards became one of our ministers and was superannuated last year. In a letter to the committee he states that nothing of the old church remained except the walls. A choir loft was added to the rear of the pulpit, circular galleries on the front and sides were built, the roof was made steep with open finish ceiling, new windows placed, towers built on both front corners with one of them continuing up into a high spire, modern and beautiful pews as well as a pipe organ—the first such instrument the church had—installed. The basement consisted of three rooms for the primary department of the Sunday School, the Board of Stewards and general assembly. This was the most modern church building in the city at that time.

Only the lecture or Sunday School room in the basement was finished until after the war. It was here that the services were conducted during that period.

During the days of the War Between the States Thos. H. Early (1860-62) and Jno. S. Lindsay (1862-65) were our pastors. The records indicate "in the army" after many of the names of members, some of whom never returned. It was said that Lindsay endeared himself to the people because of his work among the wounded soldiers brought here.

2nd  
bldg

The n  
173 in  
Th  
pastor  
his na  
He w  
wards  
W. B  
After  
witne  
day  
buildi  
W  
reviv  
1868  
man  
ing a  
this c  
its m  
L  
churc  
ever,  
amon  
after  
lege.  
Th  
Twitt  
ing  
Mitel  
audie  
thoug  
brilli  
being  
churc  
J.  
Conf  
past  
years  
good  
J.  
busin  
reviv

W. Aiken Smart (1913-14) is a son of Dr. R. D. Smart, who five years previous was pastor of First Church. Young Smart was recognized as one of the most promising young men in the Conference. His pastorate was terminated in the summer of 1914 by a call to a professorship in Emory University, which he ably fills today. But he did much in this one year for First Church, whose membership for the first time reached the thousand mark. In his final meeting with the quarterly conference he stated his greatest regret in leaving Charlottesville was that he would not be its pastor when the new church was completed.

L. T. Williams (1914-16), now superannuated and living in Richmond, served First Church during two years when unsuccessful efforts for a new church were continued. A net gain of 218 members and an even greater increase in the Sunday School were made.

The years 1916-20 found the affable J. K. Joliff as our pastor. Many efforts to secure a new church met with the failure which befell the previous ones, but the membership showed a net gain of one hundred and fifty. The church for the sixth time entertained the Virginia Conference in 1918. Bishop Hendrix presiding and Dr. B. F. Lipscomb, a former pastor and Presiding Elder, serving as secretary.

In the fall of 1920 H. P. Myers, a young minister who had not served a church of the first rank was sent to Charlottesville, because he had performed his task so well in the smaller churches the Bishop and his advisors believed he could build a new church. What he lacked in years was more than offset in energy, earnestness and good judgment. He spent some months in visiting his members and reviving the sentiment for a new building.

On April 4, 1921, a committee composed of N. T. Shumate, W. H. Snyder, B. G. Childs, Dr. Wm. R. Smithey, O. E. Hawkins, H. B. Graves, J. D. Via, W. R. Barksdale, W. E. Wilson, and S. F. Hamm was appointed to secure pledges of \$100,000 for a new church. So well was this duty performed that \$104,431 was subscribed within a few weeks.

The next obstacle to be overcome was the location. This question had been discussed for many years and had caused a division of opinion. Some members desired the old site; others wanted a new and better located lot. Options had



been secured and allowed to expire for years; committees had been unable to solve this vexing problem.

The church wisely secured its pledges before appointing on July 25, 1921 a committee on location composed of M. V. Pence, chairman of the board; O. E. Hawkins, its treasurer; and N. T. Shumate. In the following September the location now used (bounded by First High and Jefferson Streets) was accepted.

On October 10, 1921, a committee on church plans consisting of N. T. Shumate, J. E. Harrison, W. H. Snyder, B. G. Childs, and S. F. Hamm was appointed. On October 31, 1921, Jos. Hudnut of New York City was selected as architect. The plans and specifications were adopted the following February.

The building committee, composed of J. R. Morris, M. V. Pence and N. T. Shumate, arranged with the Charlottesville Lumber Company to erect the church on a cost plus ten per cent commission. The firm, however, donated half of its commissions to the church in addition to the liberal contributions made by several members of the firm who were members of the church. J. E. Harrison, Vice-President of the Company, and a member of the board, supervised the work and endeavored to make the structure a monument to the city.

Ground for the building was broken on March 12, 1923 at which time Bishop Du Bose, who was residing in Charlottesville spoke. The work was immediately begun and rushed, although a great amount of earth had to be moved. So rapidly did this progress that the laying of the corner stone by the Masonic Grand Lodge of Virginia was held on March 31, 1924, M. W. Callahan being the Grand Master. Bishop Candler delivered a great address on the occasion.

The work on this large plant went forward so quickly that the last service was conducted in the old church on Sunday, October 5, 1924, a day mingled with rejoicing because of the progress made in achieving our goal of having one of the best church plants in Southern Methodism and sadness because we were leaving our old church which had housed us since 1859 and the site of our church home since our organization.

On the following Sunday, November 1, 1924, Dr. Myers preached the first sermon in the new church. Though the

Present  
bldg

main auditorium was not completed until the following fall. In the meantime the social room was used for the church services. The Sunday School building was used, however, from the first day we entered the church.

While the four year pastorate of Dr. Myers will always be remembered because of the erection of the church, it would be recorded as one of the most successful in our history if the edifice had not been constructed. At the same time he was erecting the church he was building the membership and Sunday School and effecting an organization for effective work.

Henry C. Pfeiffer was assigned the task of finishing the church and occupying the main auditorium on the first Sunday in December, 1925. Bishop McMurry preached at both services on this occasion to one of the largest congregations ever assembled in Charlottesville. During the week former pastors were present to conduct the services.

The building has an auditorium that will seat 975; a social room of the same size to care for the social and physical needs of the church; a student club room, dedicated to the memory of Dr. F. H. Smith, a chapel with a seating capacity of 300, which is used as an assembly room for the adult department of the Sunday School, prayer services and Epworth League; a large and well furnished kitchen; a comfortable ladies parlor, and above all ample auditoriums and class rooms for every department of the church school.

The lots upon which the church is erected, building and equipment cost slightly more than \$300,000, of which the Board of Church Extension of the Methodist Episcopal Church, South, gave \$72,125.42 out of funds left from war work and the Board of Missions of the Virginia Conference gave \$20,000. When the building was completed the church owed a debt of \$109,700 which has been reduced to \$51,800.

So well did Dr. Pfeiffer perform his duties that he served the church from 1924-28, being the sixth and last pastor to serve us for four consecutive years. He was at his best in organizing the work so as to use the new plant to its maximum capacity. As a preacher, he was among the best in the conference; as a gentleman, none surpassed him. His pastorate marked four years of growth in every phase of the work of the church.

J. W. Moore (1928-30) came to First Church after

a rich and successful pastorate in many of our largest churches. He is a deep thinker and able preacher with a wonderful storehouse of apt illustrations to aid him in driving home a truth. The membership continued to increase and every department of the church was working well when he was appointed to the Eldership of the Petersburg District at the end of his second year.

The beautiful copy of Raphael's Transfiguration in the north end of the church auditorium was the work of and presented on October 26, 1930, by Mrs. Ada Woodson Quarles, a faithful and useful member of the church, as a memorial to her father, Rev. John T. Payne, who died December 23, 1918, after being a member of the Virginia Conference for more than thirty years and to her brother, Corporal Maurice L. Payne, Co. D, 317th Infantry Division, A. E. F., who was killed in France, July 29, 1918.

Because their service to us have been so recent and helpful, mention is made of the Eldership of: W. Archie Wright, 1921-25, who came to the district as a young Elder. He served and greatly aided us during the period when we were erecting our church. M. S. Colonna proved a capable, patient and efficient leader. T. F. Carroll, another young man, showed remarkable executive ability as well as being an able preacher. Daniel T. Merritt, our present Elder, won us by his able leadership and lovely character. We wish we could keep him in his responsible position indefinitely.

C. C. Bell (1930-33) a young and energetic preacher who was not afraid of hard work followed Dr. Moore for three years of diligent labor during a time when the people were facing the depression and debt on the building courageously. He went from First Church to Trinity, Newport News, where he is proving quite successful with a splendid program of work.

In 1933 the members of the church were made happy by the return of George E. Booker whom many remembered so pleasantly from his former pastorate. He left us an able man, but returned enriched by his pastorate in many of the leading churches in the conference as well as the Eldership of the Richmond District for four years. He is recognized as one of the ablest ministers in Southern Methodism. His popularity with both the clergy and laymen is



THE SECRETARY  
OF THE INTERIOR'S  
STANDARDS FOR  
REHABILITATION &

ILLUSTRATED  
GUIDELINES ON  
**SUSTAINABILITY**  
FOR  
REHABILITATING  
HISTORIC  
BUILDINGS



U.S. Department of the Interior  
National Park Service  
Technical Preservation Services

## Sustainability

Before implementing any energy conservation measures to enhance the sustainability of a historic building, the existing energy-efficient characteristics of the building should be assessed. Buildings are more than their individual components. The design, materials, type of construction, size, shape, site orientation, surrounding landscape and climate all play a role in how buildings perform. Historic building construction methods and materials often maximized natural sources of heating, lighting and ventilation to respond to local climatic conditions. The key to a successful rehabilitation project is to identify and understand any lost original and existing energy-efficient aspects of the historic building, as well as to identify and understand its character-defining features to ensure they are preserved. The most sustainable building may be one that already exists. Thus, good preservation practice is often synonymous with sustainability. There are numerous treatments--traditional as well as new technological innovations--that may be used to upgrade a historic building to help it operate even more efficiently. Increasingly stricter energy standards and code requirements may dictate that at least some of these treatments be implemented as part of a rehabilitation project of any size or type of building. Whether a historic building is rehabilitated for a new or a continuing use, it is important to utilize the building's inherently-sustainable qualities as they were intended. It is equally important that they function effectively together with any new measures undertaken to further improve energy efficiency.



[15] Glass skylight illuminates historic shopping arcade.

16



17



[16-18] Inherently sustainable features of historic buildings: Shutters and a deep porch keep the interior cool in a historic house in a warm climate (top); a skylight provides natural light to the interior of this mid-20th century house (center); partially glazed partitions and doors allow natural light into the corridor of a historic office building (bottom).

18



## PLANNING

### RECOMMENDED

### NOT RECOMMENDED

Forming an integrated sustainability team when working on a large project that includes a preservation professional to ensure that the character and integrity of the historic building is maintained during any upgrades.

Omitting preservation expertise from a sustainability project team.

Analyzing the condition of inherently-sustainable features of the historic building, such as shutters, storm windows, awnings, porches, vents, roof monitors, skylights, light wells, transoms and naturally-lit corridors, and including them in energy audits and energy modeling, before planning upgrades.

Ignoring inherently-sustainable features of the existing historic building when creating energy models and planning upgrades.

Identifying ways to reduce energy use, such as installing fixtures and appliances that conserve resources, including energy-efficient lighting or energy-efficient lamps in existing light fixtures, low-flow plumbing fixtures, sensors and timers that control water flow, lighting and temperature, before undertaking more invasive treatments that may negatively impact the historic building.

Prioritizing sustainable improvements, beginning with minimally invasive treatments that are least likely to damage historic building material.

Beginning work with substantive or irreversible treatments without first considering and implementing less invasive measures.

## SOLAR TECHNOLOGY

72



73



**Recommended:** [72-73] Solar panels were installed appropriately on the rear portion of the roof on this historic row house that are not visible from the primary elevation.

**RECOMMENDED**

**NOT RECOMMENDED**

Considering on-site, solar technology only after implementing all appropriate treatments to improve energy efficiency of the building, which often have greater life-cycle cost benefit than on-site renewable energy.	Installing on-site, solar technology without first implementing all appropriate treatments to the building to improve its energy efficiency.
Analyzing whether solar technology can be used successfully and will benefit a historic building without compromising its character or the character of the site or the surrounding historic district.	Installing a solar device without first analyzing its potential benefit or whether it will negatively impact the character of the historic building or site or the surrounding historic district.
Installing a solar device in a compatible location on the site or on a non-historic building or addition where it will have minimal impact on the historic building and its site.	Placing a solar device in a highly-visible location where it will negatively impact the historic building and its site.
Installing a solar device on the historic building only after other locations have been investigated and determined infeasible.	Installing a solar device on the historic building without first considering other locations.

74



**Recommended:** [74] Free-standing solar panels have been installed here that are visible but appropriately located at the rear of the property and compatible with the character of this industrial site.

75



**Not Recommended:** [75] Solar roof panels have been installed at the rear, but because the house is situated on a corner, they are highly visible and negatively impact the character of the historic property.

## SOLAR TECHNOLOGY

### RECOMMENDED

### NOT RECOMMENDED

Installing a low-profile solar device on the historic building so that it is not visible or only minimally visible from the public right of way: for example, on a flat roof and set back to take advantage of a parapet or other roof feature to screen solar panels from view; or on a secondary slope of a roof, out of view from the public right of way.	Installing a solar device in a prominent location on the building where it will negatively impact its historic character.
Installing a solar device on the historic building in a manner that does not damage historic roofing material or negatively impact the building's historic character and is reversible.	Installing a solar device on the historic building in a manner that damages historic roofing material or replaces it with an incompatible material and is not reversible.
	Removing historic roof features to install solar panels.
	Altering a historic, character-defining roof slope to install solar panels.
	Installing solar devices that are not reversible.
Installing solar roof panels horizontally -- flat or parallel to the roof—to reduce visibility.	Placing solar roof panels vertically where they are highly visible and will negatively impact the historic character of the building.

76



77



79



**Not Recommended:** [79] Although installing solar panels behind a rear parking lot might be a suitable location in many cases, here the panels negatively impact the historic property on which they are located.

**Recommended:** [76-77] Solar panels, which also serve as awnings, were installed in secondary locations on the side and rear of this historic post office and cannot be seen from the front of the building. [78] Solar panels placed horizontally on the roof of this historic building are not visible from below.

78





## ROOFS—COOL ROOFS AND GREEN ROOFS

85



### RECOMMENDED

### NOT RECOMMENDED

Retaining and repairing durable, character-defining historic roofing materials in good condition.

Replacing durable, character-defining historic roofing materials in good condition with a roofing material perceived as more sustainable.

Analyzing whether a cool roof or a green roof is appropriate for the historic building.

Installing a cool roof or a green roof on a flat-roofed historic building where it will not be visible from the public right of way and will not negatively impact the building's historic character.

Installing a cool roof or a green roof without considering whether it will be highly visible from the public right of way and will negatively impact the building's historic character.

Selecting appropriate roofing materials and colors when putting a new cool roof on the historic building.

Installing a cool roof that is incompatible in material or color with the historic building.

Ensuring that the historic building can structurally accommodate the added weight of a green roof and sensitively improving the structural capacity, if necessary.

Adding a green roof that would be too heavy and would damage the historic building or supplementing the structural capacity of the historic building in an insensitive manner.

86



**Recommended:** [85-86] A cool or green roof is best installed on a flat roof where it cannot be seen from the public right of way and will not negatively impact the character of the historic building.

87



**Not Recommended:** [87] Historic roofing materials in good condition should be retained rather than replaced with another material perceived as more sustainable, such as, in this case, solar roofing shingles.

88



**Not Recommended:** [88] This new, cool white metal roof is not an appropriate material or color for this historic mid-20th century house.



## Subject: Slate Roof Treatments

Applicable Standards: 2. Retention of Historic Character  
6. Repair/Replacement of Deteriorated or Missing Features Based on Evidence

**Issue:** The roof of a historic building is often its most character-defining feature and a roof covered in slate only adds to this character. Slate as a roofing material continues to be one of the most durable materials available, with a life-span as long as 150 years. It is also weatherproof, aesthetically appealing, and readily obtainable. Although the recommended treatment is to repair a slate roof or replace it in kind if necessary, with rising costs and a variety of alternative roofing products on the market, property owners may prefer to replace slate with alternative roofing materials. These include asphalt-based fiberglass shingles, polymer-based shingles (often containing recycled materials such as rubber), and less successfully, concrete and metal shingles. Replacing a deteriorated historic roof may fail to meet the Secretary's Standards if it is replaced with a material that does not have the same visual qualities as the original. Slate roofs can often be repaired and some roofers specialize in this practice by removing and replacing only the most damaged tiles and keeping as much of the original as possible. This is the recommended approach. It may be accomplished on an as-needed basis and is generally cost effective. Most importantly, it preserves the roofing material, and thus, preserves the building's historic character.

At times, however, slate may be damaged beyond repair or missing entirely. What, then, is the most appropriate treatment? Replacement of the slate in kind to match the existing is always the preferred treatment. However each project must be evaluated on a case-by-case basis, taking into account the existing condition of the roof, its profile and visibility, the availability of materials, and the overall design of the building.

**Application 1 (Compatible Treatment):** After surveying approximately fifty buildings in this Colonial Revival-Style apartment complex, it was determined that the 80-year old slate roofing was in poor condition. As a result, the owner proposed that all the slate be removed and replaced with a polymer-based substitute. The most distinctive features of these simple 2-1/2 story brick garden apartments are their hipped and gabled slate roofs, which are very visible within the complex. Therefore, replacement with a substitute material was deemed incompatible and the owner agreed to use new slate from the original quarry. The new slate roofs, which require only seasonal maintenance, are a sound investment and historically appropriate.



*Typical view of Colonial-Revival apartment building in complex before rehabilitation. Note the mottled appearance of original slate due to numerous past repairs.*



*Close up of damaged and previously repaired slate.*



*Right: New rubber slate (center; left) next to historic slate (right).*

**Application 2 (Compatible Treatment):** This 1894 example of Second Empire architecture is “high style” with pedimented dormers, balconies, corbelled cornices, a dominant central tower, and a small mansard roof covered in slate. Prior to rehabilitation the property was in extremely deteriorated condition and although some of the slate on the mansard was still there, it was delaminating, fractured, and partially painted. Since the roof is only one of many decorative elements making up the primary façade and not the sole defining feature of the building, replacing the slate with a polymer-based substitute slate was an acceptable alternative. Although the replacement slate is visible,

it replicates the decorative fish-scale pattern of the historic slate and, thus, has the same appearance as the original roof. Because the building is on a narrow street and is generally viewed at an angle rather than head on, the mansard roof is not the major focal point.

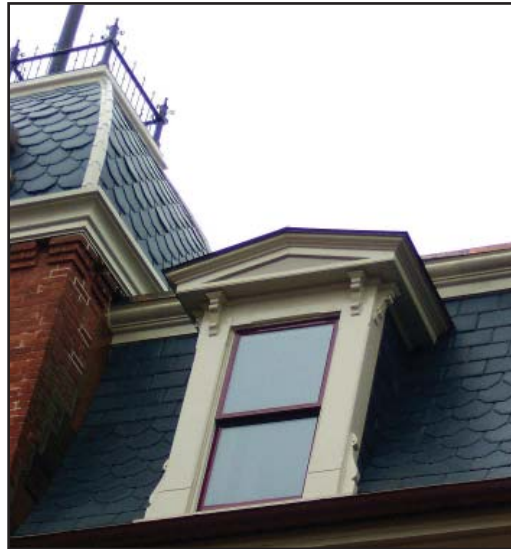

*Left: Second Empire former hotel, built in 1894.*

*Right: Close-up of substitute slate after installation.*

**Application 3: (Compatible Treatment):** After careful inspection, the slate roof of this circa 1895 former brewery was determined to be beyond repair and during rehabilitation was replaced with high quality asphalt-based fiberglass shingles. The new asphalt shingles are the same size and color as the original slate and have similar shadow lines. The roof, with its many towers, turrets and monitors, is clearly a distinctive and prominent feature, but because of the massive scale and height of the building, it can only be viewed at a considerable distance. For this reason, a substitute roofing material was acceptable in this instance.

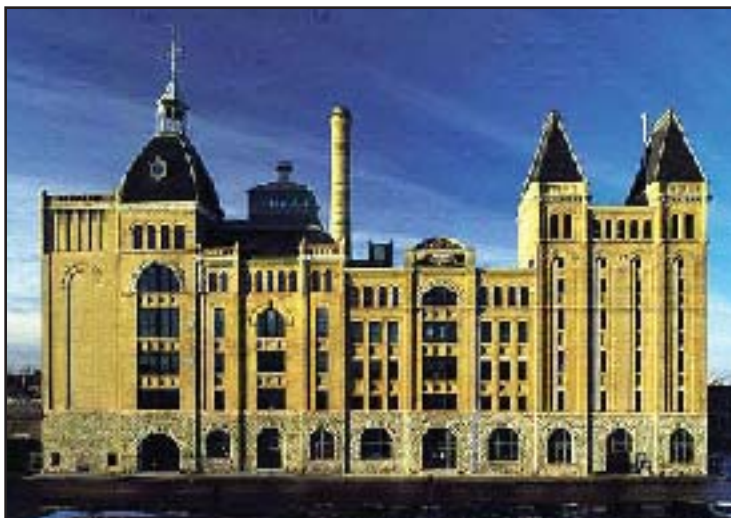

*Above: Close up of the replacement roof after installation.*

*Left: View of the historic brewery taken from a distance after rehabilitation.*

Audrey T. Tepper, Technical Preservation Services, National Park Service

These bulletins are issued to explain preservation project decisions made by the U.S. Department of the Interior. The resulting determinations, based on the [Secretary of the Interior's Standards for Rehabilitation](#), are not necessarily applicable beyond the unique facts and circumstances of each particular case.



## Subject: Incorporating Solar Panels in a Rehabilitation Project

Applicable Standards: 2. Retention of Historic Character  
9. Compatible Additions/Exterior Alterations

**Issue:** Enhancing the energy efficiency of a historic building is important. To that end, it is often possible to install features such as solar panels and photovoltaic cells provided they are installed in a sensitive manner. Because these elements must be positioned to take advantage of unobstructed sunlight, the roof of a historic structure is an obvious location. The roofline of a historic building is often a distinctive feature. Therefore, the installation of solar panels should conform to guidance regarding rooftop additions, i.e. that they be minimally visible, to avoid altering the historic character of the building. Historic buildings with a flat roof or parapet can usually accommodate solar panels because the panels will be hidden, while properties with a hipped or gabled roof are generally not good candidates for a rooftop solar installation. Solar panels on historic buildings should not be visible from the public right of way such as nearby streets, sidewalks or other public spaces.

In circumstances where solar collectors are not placed on rooftops, they should only be positioned in limited or no-visibility locations in secondary areas of the property. Vegetation or a compatible screen may also be an option to further reduce the impact of these features on a historic property. For some historic buildings, it may not be possible to incorporate solar panels and meet the Secretary of the Interior's Standards for Rehabilitation.

### Application 1 (*Compatible treatment*):

The rehabilitation of this mid-nineteenth century mill incorporated a large, roof-mounted photovoltaic installation. Although the historic building does not have a parapet wall at the roofline, the height of the building and the arrangement of the panels render the entire installation invisible from the ground. It is important to note that the panels are placed horizontally. Had the panels been installed with a vertical tilt, the angle required to maximize efficiency would have caused the panels to extend significantly higher above the roof. Simply changing the direction in which the panels are tilted can affect their visibility and reduce their impact on the character of the historic property.

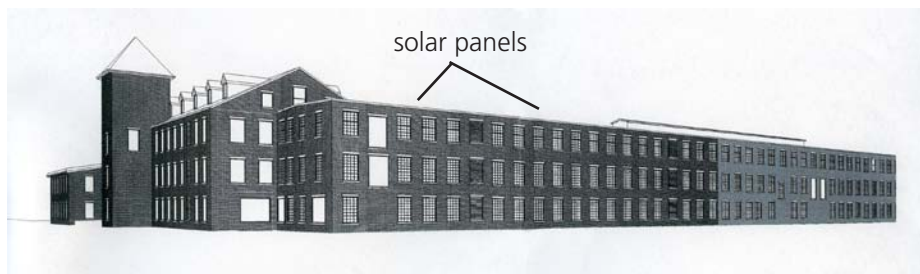

*Because of the size of this historic mill, a large array of solar panels could be installed on the flat roof without being seen from the ground.*



*Solar panels installed on the flat roof.*

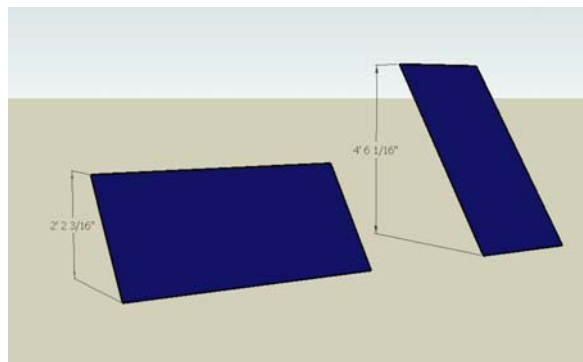

*By placing the panels horizontally, the overall height of the installation and its visibility is reduced.*

**Application 2** (*Incompatible treatment*): During the rehabilitation of this late-nineteenth century commercial building, a conspicuous rooftop monitor with prominent solar panels and skylights was constructed on the one-story structure. The size and finish of this rooftop addition are incompatible with the historic character of the building. However, the building could have accommodated both skylights and solar panels if they had been installed differently. An alternative design that could have met the Standards would have included low-profile skylights and solar panels concealed behind the parapet wall.



*The addition of a large rooftop monitor featuring skylights on the front slope and solar panels on the rear slope is not compatible with the historic character of this small, one-story commercial building.*

**Application 3** (*Compatible treatment*): The rehabilitation of this historic post office incorporated solar panels as dual-function features: generation of electricity and shading for south-facing windows. In this instance, the southern elevation of the building is also a secondary elevation with limited visibility from the public right of way. Additionally, because this area of the building is immediately next to the post office’s loading dock, it has a more utilitarian character than the primary facades and, therefore, can better accommodate solar panels. Because the panels are in a suitable location at the rear of the property and are appropriately sized to serve as awnings, they do not affect the overall historic character of the property. Additionally, a screen of tall plantings shields the solar panels from view from the front of the building, further limiting their visibility.



*Above: Shown from the rear of the property, these solar panels serve a secondary function as awnings to shade south-facing windows. Because of their location at the back of the building immediately adjacent to a loading dock, the installation of these panels does not affect the historic character of the property.*



Tall plantings shield solar panels from view from the front of the building.

*Left: The solar panels are not visible from the front of the building. Additionally, even if the vegetation were removed, the installation would only be minimally visible along an alley at the rear of a secondary side elevation.*

Jenny Parker, Technical Preservation Services, National Park Service

These bulletins are issued to explain preservation project decisions made by the U.S. Department of the Interior. The resulting determinations, based on the [Secretary of the Interior's Standards for Rehabilitation](#), are not necessarily applicable beyond the unique facts and circumstances of each particular case.

August 2009, ITS Number 52

## National Park Service

---

### ARTICLE

# Solar Panels on Historic Properties: On a Cross Gable

## King's Daughters Home, North Carolina

It is often easier to accommodate solar hot water systems than photovoltaic systems on historic properties because fewer panels are necessary. Solar hot water can often operate utilizing only a few panels, while photovoltaic systems often require multiple arrays to produce enough electricity to be worth the investment.

Several specific circumstances made it possible to install solar collectors on a street-facing slope of this gable roof. The panels were flush-mounted on a low-pitch roof, and only two were required. They were installed on a portion of the roof that is set back from the face of the building behind a prominent pediment. Thus, the solar collectors are visible but not conspicuous, and this installation meets the Standards in the context of the overall project.



The visual prominence of the two solar collectors installed on this cross gable is further minimized by the complexity of this elevation.



Front of the King's Daughters Home. The solar panels are installed on the facade that faces the street at the right edge of this photograph.

**Next article: Solar panels on a rear porch roof**

VOLUME 11, NUMBER 1

## National Park Service

---

### ARTICLE

# Solar Panels on Historic Properties: On a Low-Slope Gable

## Vermont Residence

The gable end of this historic apartment building faces the street. Low profile solar collectors for a water heating system were flush mounted on the sloped roof on the south side of the gable. Though visible, these few panels have relatively little impact on the historic character of the property. However, if the roof had been a more prominent feature of the property, this installation may not have been appropriate.



Low-profile solar collectors located on the south side of the gable roof are minimally visible.

From this angle, the panels are more noticeable, yet the historic character of the building is not significantly diminished.



**Next article: Solar panels on a cross gable**

## **Certificate of Appropriateness - Demolition**

BAR # 23-01-01

207-211 Ridge Street, TMP 290029000

Ridge Street ADC District (contributing)

Owner: The Salvation Army

Applicant: Erin Hannegan / Mitchell-Matthews Architects & Planners

Project: Phased demolition of two, c1960s buildings.

Application components (please click each link to go directly to PDF page):

- [Staff Report](#)
  
- [Application Submittal](#)



**City of Charlottesville  
Board of Architectural Review  
Staff Report  
January 18, 2023**



**Certificate of Appropriateness Application**

BAR 23-01-0  
207-211 Ridge Street, TMP 290029000  
Ridge Street ADC District (contributing property)  
Owner: The Salvation Army  
Applicant: Mitchell Matthews Architects & Planners  
Project: Building demolition

---



**Background**

Year Built: Chapel/primary building 1965. Transient shelter (rear) c1980; Addition (north) 1992.  
District: Ridge Street ADC District  
Status: *Contributing* (Note: By code, all structures in the Ridge Street ADC District are designated as contributing, regardless of year built or historic significance. Note: The site is not within a NRHP Historic District, nor individually designated.)

The facility, constructed by the Salvation Army as a shelter and transient facility, includes a two-story, brick chapel and three-story brick building, both constructed in 1965, a two-story transient shelter (at the rear), constructed after 1974, likely in 1980, and a two-story brick addition (at the north side), constructed in 1992.

**Prior BAR Actions:**

n/a

**Application**

- Submittal: Mitchell Matthews Architects & Planners drawings and submittal dated January 11, 2023: Sheets 1 – 11.
  - Supplement A: Tree Protection Plan, dated January 11, 2023: Cover, Sheets 13-17.

Request CoA for demolition of three brick structures constructed in 1965, c 1972, and c 1980, respectively. Demolition [to be phased and sequenced with new construction] will allow the Salvation Army to expand the facility and increase and enhance the services provided per its mission.

Note: The proposed new construction will require approval of Special Use Permit [related to setbacks], therefore, at a later date the BAR will review that request and make a recommendation to City Council. Additionally, the planned redevelopment of the site, regardless of the SUP, will require BAR review and approval of a CoA.

**Discussion and Recommendations**

Per a review of the standards for considering demolitions (Code Sec. 34-278) and the Review Criteria for Demolition in the Design Guidelines (see below), staff concurs with the applicant’s comments, generally, and finds no compelling argument to deny the requested demolition.

The property is within the Ridge Street ADC District and the structures are designated *contributing*; however, the property is **not** within a National Register of Historic Places (NRHP) historic district, nor are the structures designated individually. Within Subarea C of the ADC District: two structures date to the 1800s; five date to the 1960s; four to after 1980.

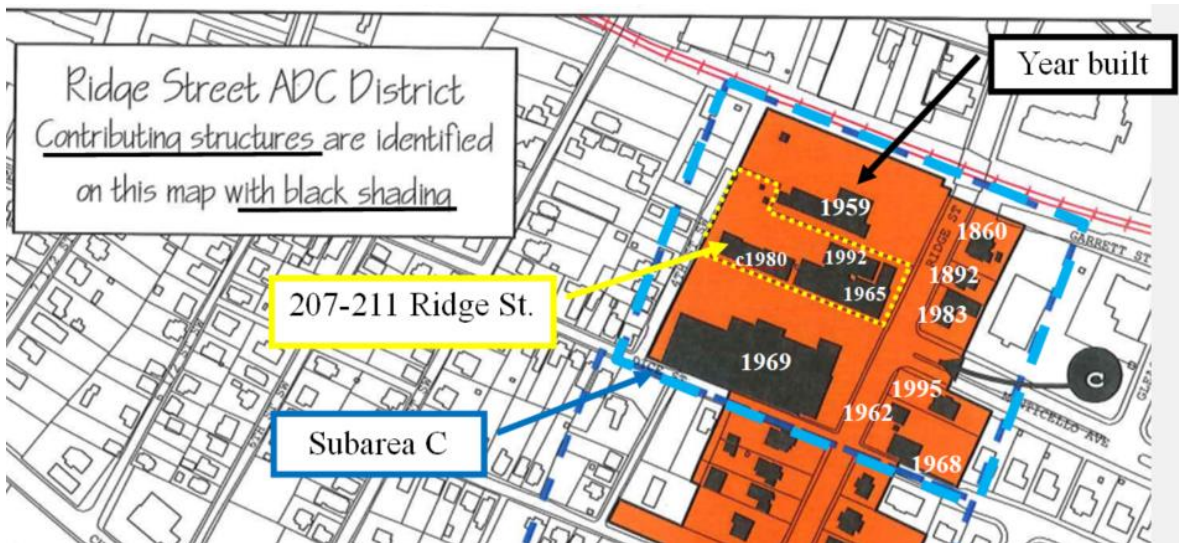

**NRHP Historic Districts and Individually Designated Properties**

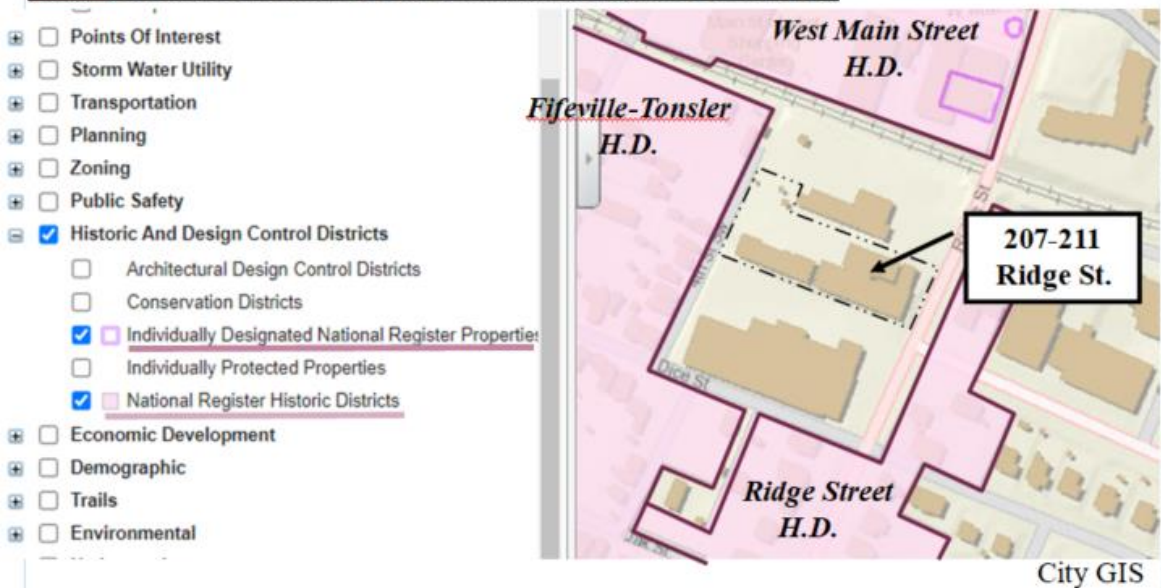

Per preliminary discussions with the applicant, the planned programming of this site anticipates the sequenced demolition of each structure and construction of buildings so as to allow continued use with minimal, if any, disruptions to the operation and services provided by the facility. BAR approval is required for the proposed new structures, when those designs are completed; however, with the demolition CoA, the BAR may consider conditions related to the timing, sequencing, etc. for the razing of each building.

The BAR may also want to discuss the 56” [red] oak at the front of the site. (See Appendix and the applicant’s Supplement A.) Protection the tree during demolition and later construction is preferred; however, even if expressed as a condition of approval staff cannot advise on how practicable or realistic that might be.

Should the BAR approve the request, staff suggests the following conditions of approval:

- Staff approval of the demolition permit [when that application is submitted] is contingent upon:
  1. Applicant providing for the BAR record documentation of the existing building. [In addition to the photos provided, documentation will include dimensioned floor plans and elevations. Similar to documentation provided for 210 West Market Street, August 2022; 1532 Virginia Ave, January 2019.]
  2. Either a *condition* or a *recommendation* that during the demolition and later redevelopment of the site all efforts be made to preserve the large oak tree at the front of the property. (See photos in Appendix.)
  3. An approved building permit for construction of the new buildings. [The BAR may want to link the sequence and timing of demolition of individual structures and the related construction of new.]

Or, in lieu of item 3:

- BAR approval of proposed site treatment following demolition and prior to site redevelopment. Unless other criteria of the ADC District Design Guidelines prevail, BAR will apply Chapter 2. Site Design.

### **Suggested Motions**

*Approval:* Having considered the standards set forth within the City Code, including the ADC District Design Guidelines, I move to find that the proposed demolition of 207-211 Ridge Street satisfies the BAR’s criteria and guidelines and is compatible with this property and other properties in the Downtown ADC District, and that the BAR [approves the application as submitted].

Or [...approves the application as submitted with the following conditions:] ...

*Denial:* Having considered the standards set forth within the City Code, including the ADC District Design Guidelines, I move to find that the proposed demolition of 207-211 Ridge Street does not satisfy or the BAR’s criteria and guidelines and is not compatible with this property and other properties in the Downtown ADC District, and for the following reasons the BAR denies the application as submitted:...

### **Criteria, Standards, and Guidelines**

#### **Review Criteria Generally**

Sec. 34-284(b) of the City Code states that,

In considering a particular application the BAR shall approve the application unless it finds:

- (1) That the proposal does not meet specific standards set forth within this division or applicable provisions of the Design Guidelines established by the board pursuant to Sec.34-288(6); and
- (2) The proposal is incompatible with the historic, cultural or architectural character of the district in which the property is located or the protected property that is the subject of the application.

### **Pertinent design guidelines for Tree Protection**

From Chapter II of the Design Guidelines: Site Design and Elements

Link: [Chapter 2 Site Design and Elements](#)

#### **B. Plantings**

Plantings are a critical part of the historic appearance of the residential sections of Charlottesville’s historic districts. The character of the plantings often changes within each district’s sub-areas as well as from district to district. Many properties have extensive plantings in the form of trees, foundation plantings, shrub borders, and flowerbeds. Plantings are limited in commercial areas due to minimal setbacks.

- 1) Encourage the maintenance and planting of large trees on private property along the streetfronts, which contribute to the “avenue” effect.
- 2) Generally, use trees and plants that are compatible with the existing plantings in the neighborhood.
- 3) Use trees and plants that are indigenous to the area.
- 4) Retain existing trees and plants that help define the character of the district, especially street trees and hedges.
- 5) Replace diseased or dead plants with like or similar species if appropriate.
- 6) When constructing new buildings, identify and take care to protect significant existing trees and other plantings.
- 7) Choose ground cover plantings that are compatible with adjacent sites, existing site conditions, and the character of the building.
- 8) Select mulching and edging materials carefully and do not use plastic edgings, lava, crushed rock, unnaturally colored mulch or other historically unsuitable materials.

### **Pertinent Standards for Review of Demolitions:**

From City Code Section 34-278. - Standards for considering demolitions.

The following factors shall be considered in determining whether or not to permit the moving, removing, encapsulation or demolition, in whole or in part, of a contributing structure or protected property:

- (a) The historic, architectural or cultural significance, if any, of the specific structure or property, including, without limitation:
  - (1) The age of the structure or property;

**Staff comment:** The existing structures were constructed in three primary phases with minor alterations likely in intervening years.

- Chapel and primary building: 1965.
- Transient Shelter: c1980
- Addition (north): 1992



(2) Whether it has been designated a National Historic Landmark, listed on the National Register of Historic Places or listed on the Virginia Landmarks Register;

**Staff comment:** Neither the parcel or structures are listed on the NRHP or located within a NRHP historic district.

(3) Whether, and to what extent, the building or structure is associated with a historic person, architect or master craftsmen, or with a historic event;

**Staff comment:** No known associations.

(4) Whether the building or structure or any of its features, represent an infrequent or the first or last remaining example within the city of a particular architectural style or feature;

**Staff comment:** No such characteristics are attributed to these buildings.

(5) Whether the building or structure is of such old or distinctive design, texture or material that it could not be reproduced, or could be reproduced only with great difficulty; and

**Staff comment:** Structures have no historical or architectural distinction.

(6) The degree to which distinguishing characteristics, qualities, features, or materials remain.

**Staff comment:** None. Demolitions will raze the three structures.

(b) Whether, and to what extent, a contributing structure is linked, historically or aesthetically, to other buildings or structures within an existing major design control district, or is one of a group of properties within such a district whose concentration or continuity possesses greater significance than many of its component buildings.

**Staff comment:** The property and structures are not linked historically or aesthetically to other properties and structures within the ADC District. The property is **not within a NRHP historic district**.

(c) The overall condition and structural integrity of the building or structure, as indicated by studies prepared by a qualified professional engineer and provided by the applicant or other information provided to the board.

**Staff comment:** The current use of the buildings and the photos provided by the applicant suggest the structures are not unstable or in poor condition. Demolition is requested to facilitate redevelopment of the site.

(d) Whether, and to what extent, the applicant proposes means, methods or plans for moving, removing, or demolishing the structure or property that preserves portions, features or materials that are significant to the property's historic, architectural, or cultural value.

**Staff comment:** Proposal is to raze all of the structures; no elements, features or materials will be retained. The buildings and site are not historically, architecturally, or culturally significant.

### **Pertinent design guidelines re: Demolitions**

Link: [Chapter 7 Moving and Demolition](#)

#### **B. Demolition of Historic Structures**

##### Review Criteria for Demolition

1) The standards established by the City Code, Section 34-278.

**Staff comment:** See comments above, under *Standards for considering demolitions*.

2) The public necessity of the proposed demolition.

**Staff comment:** Demolition is not a public necessity; the buildings have not been condemned or deemed unsafe. However, in considering the request, the BAR might weigh the public benefit of the site's redevelopment.

3) The public purpose or interest in land or buildings to be protected.

**Staff comment:** See comments above, under *Standards for considering demolitions*, item a.

- 4) Whether or not a relocation of the structure would be a practical and preferable alternative to demolition.

**Staff comment:** See comments above, under *Standards for considering demolitions*, item d.

- 5) Whether or not the proposed demolition would adversely or positively affect other historic buildings or the character of the historic district.

**Staff comment:** See comments under *Standards for considering demolitions*, item d.

- 6) The reason for demolishing the structure and whether or not alternatives exist.

**Staff comment:** See comments above, under *Standards for considering demolitions*, item d.

- 7) Whether or not there has been a professional economic and structural feasibility study for rehabilitating or reusing the structure and whether or not its findings support the proposed demolition.

**Staff comment:** See comments above, under *Standards for considering demolitions*, item c

#### Guidelines for Demolition

- 1) Demolish a historic structure only after all preferable alternatives have been exhausted.
- 2) Document the building thoroughly through photographs and, for especially significant buildings, measured drawings according to Historic American Buildings Survey (HABS) Standards. This information should be retained by the City of Charlottesville Department of Neighborhood Development Services and the Virginia Department of Historic Resources.
- 3) If the site is to remain vacant for any length of time, maintain the empty lot in a manner consistent with other open spaces in the districts.

**Appendix**

Existing 56” oak tree at site

(From applicant’s submittal)



(BAR staff photo)





(BAR staff photo)



(BAR staff photo)



Note: Information provided for context and discussion only

**Age of a 56” red oak:** Possibly 220 to 375 years.

Red oaks can live to 500 years, but usually live to about 300 years.

- *Tree Age calculator.* Likely 223 years old.  
([www.cliftonparkopenspaces.org/treecalculator/](http://www.cliftonparkopenspaces.org/treecalculator/))
- *How Old Is My Tree?* Likely 224 years old  
([www.purduelandscapereport.org/article/how-old-is-my-tree/](http://www.purduelandscapereport.org/article/how-old-is-my-tree/))
- *How old is that oak?* At least 300 years old.  
([conservemc.org/how-old-is-that-oak/](http://conservemc.org/how-old-is-that-oak/))
- *Tree Age Calculator.* Likely 323 years old.  
([www.tree-guide.com/tree-age-calculator](http://www.tree-guide.com/tree-age-calculator))
- The Friends of the Wild Flower Garden. Likely 375 years old  
([www.friendsofthewildflowergarden.org/pages/photosubpages/photoinfo/pages/treeagecalculator.html](http://www.friendsofthewildflowergarden.org/pages/photosubpages/photoinfo/pages/treeagecalculator.html))

### A Guide to Preserving Trees in Development Projects

<https://extension.psu.edu/a-guide-to-preserving-trees-in-development-projects>

Updated: August 30, 2022

**Table 1: Guidelines for Tree Protection Zones.** Distances should be increased for trees of poor vigor and to protect young and other trees with low branching from severe pruning of limbs. This table is adapted from a table provided courtesy of the International Society of Arboriculture, Savoy, IL.

Species Tolerance to Impacts	Tree Age	Distance From Trunk* (feet per inch of trunk diameter)	Distance for 56" tree)
Tolerant	Mature	1.0-ft	56-ft
Intermediate	Mature	1.25-ft	70-ft
Sensitive	Mature	1.5-ft	84-ft

\*These distances are based on a tree's tolerance to root pruning and soil disturbance and may not be adequate to protect branches of young trees or other trees with low branching. Because severe pruning would destroy the form of such trees, fencing at the dripline or beyond should be considered.

**Table 2: Size and Tolerance of Tree Species to Construction Impacts.** This table represents opinions of the authors and information from three publications: Tree Characteristics, Protecting Trees from Construction Damage, Minnesota Extension Service, University of Minnesota; The Response of Ohio's Native and Naturalized Trees to Construction Activity, T. Davis Sydnor, School of Natural Resources, The Ohio State University; and Relative Tolerance of Tree Species to Construction Damage, Kim D. Coder, The University of Georgia Cooperative Extension Service, Forest Resources Unit.

Tolerance to construction impact can vary greatly according to site characteristics such as soil depth, individual tree characteristics such as rooting habit, prevailing weather conditions such as drought, and the degree of construction impact.

Species	Root Severance	Soil Compaction and Flooding	Mature Crown Spread (feet)	Hazard Potential Rating*
Red Oak	Tolerant	Sensitive	40-50	Low
White Oak	Sensitive	Sensitive	50-90	Low

\*Hazard Potential Rating refers to the relative potential for a tree to become hazardous due to its large size and likelihood of breakage or decay. For a tree to be considered hazardous, a likely "target" (e.g., a person, a house, or car) must be present. A high rating does not imply that an individual tree is likely to fail.

**Tree protection dimensions:** (shown on applicant's site plan)

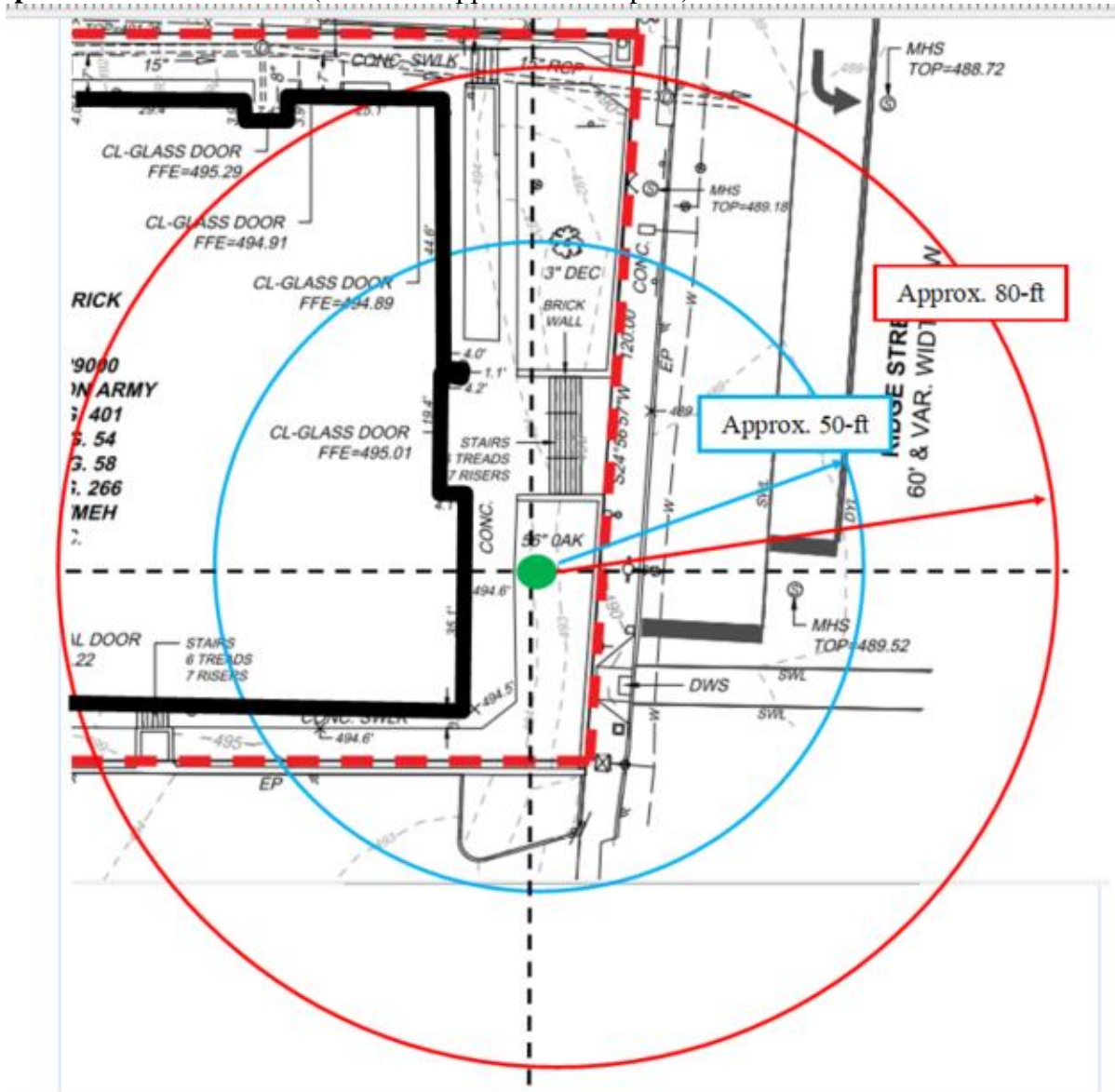

ADC District or IPP



**Board of Architectural Review (BAR)**  
**Certificate of Appropriateness ADC Districts and IPPs**

Please Return To: City of Charlottesville  
 Department of Neighborhood Development Services  
 P.O. Box 911, City Hall  
 Charlottesville, Virginia 22902  
 Telephone (434) 970-3130  
**Staff contacts:**  
**Jeff Werner wernerjb@charlottesville.gov**

Please submit the signed application form and a digital copy of submittal and attachments (via email or thumb drive).  
 Please include application fee as follows: New construction project \$375; ~~Demolition of a contributing structure \$375~~;  
 Appeal of BAR decision \$125; Additions and other projects requiring BAR approval \$125; Administrative approval \$100.  
 Make checks payable to the City of Charlottesville.  
 The BAR meets the third Tuesday of the month.  
 Deadline for submittals is Tuesday 3 weeks prior to next BAR meeting by 3:30 p.m.

Owner Name The Salvation Army Applicant Name Mitchell/Matthews Architects & Planners  
 Project Name/Description Building demolition Parcel Number 290029000  
 Project Property Address 207-211 Ridge Street

**Applicant Information**  
 Address: 300 Twin Sycamores Lane  
Charlottesville, VA 22903  
 Email: eh@mitchellmatthews.com  
 Phone: (W) 434-979-7550 (C) \_\_\_\_\_

**Property Owner Information (if not applicant)**  
 Address: 207 Ridge Street / PO Box 296  
Charlottesville, Va 22902.  
 Email: \_\_\_\_\_  
 Phone: (W) \_\_\_\_\_ (C) \_\_\_\_\_

**Signature of Applicant**  
 I hereby attest that the information I have provided is, to the best of my knowledge, correct.  
Erin Hannegan 12/28/22  
 Signature Date  
 Erin Hannegan, on behalf of Mitchell/  
 Matthews Architects & Planners  
12/28/22  
 Print Name Date

**Property Owner Permission (if not applicant)**  
 I have read this application and hereby give my consent to its submission.  
Bobby Westmorland 12/23/22  
 Signature Date  
BOBBY WESTMORLAND 12/23/22  
 Print Name Date

Do you intend to apply for Federal or State Tax Credits for this project? no

Description of Proposed Work (attach separate narrative if necessary):  
Phased demolition of two structures on site.

List All Attachments (see reverse side for submittal requirements):

<b>For Office Use Only</b>	Approved/Disapproved by: _____
Received by: _____	Date: _____
Fee paid: _____ Cash/Ck. # _____	Conditions of approval: _____
Date Received: _____	_____
Revised 2016	



**HISTORIC DISTRICT ORDINANCE:** You can review the *Historical Preservation and Architectural Design Control Overlay Districts* regulations in the City of Charlottesville Zoning Ordinance starting with Section 34-271 online at [charlottesville.gov](http://charlottesville.gov) or at [Municode.com](http://Municode.com) for the City of Charlottesville.

**DESIGN REVIEW GUIDELINES:** Please refer to the current *ADC Districts Design Guidelines* online at [charlottesville.gov](http://charlottesville.gov)

**SUBMITTAL REQUIREMENTS:** The following information and exhibits shall be submitted along with each application for Certificate of Appropriateness, per Sec. 34-282 (d) in the City of Charlottesville Zoning Ordinance:

- (1) Detailed and clear depictions of any proposed changes in the exterior features of the subject property;
- (2) Photographs of the subject property and photographs of the buildings on contiguous properties;
- (3) One set of samples to show the nature, texture and color of materials proposed;
- (4) The history of an existing building or structure, if requested;
- (5) For new construction and projects proposing expansion of the footprint of an existing building: a three-dimensional model (in physical or digital form);
- (6) In the case of a demolition request where structural integrity is at issue, the applicant shall provide a structural evaluation and cost estimates for rehabilitation, prepared by a professional engineer, unless waived by the BAR.

**APPEALS:** Following a denial the applicant, the director of neighborhood development services, or any aggrieved person may appeal the decision to the city council, by filing a written notice of appeal within ten (10) working days of the date of the decision. Per Sec. 34-286. - City council appeals, an applicant shall set forth, in writing, the grounds for an appeal, including the procedure(s) or standard(s) alleged to have been violated or misapplied by the BAR, and/or any additional information, factors or opinions he or she deems relevant to the application.

## CHARLOTTESVILLE ARCHITECTURAL DESIGN CONTROL DISTRICTS DESIGN GUIDELINES

### Chapter 1 Introduction (Part 1)

[http://weblink.charlottesville.org/public/0/edoc/793062/2\\_Introduction%20I\\_BAR.pdf](http://weblink.charlottesville.org/public/0/edoc/793062/2_Introduction%20I_BAR.pdf)

### Chapter 1 Introduction (Part 2)

[http://weblink.charlottesville.org/public/0/edoc/793063/1\\_Introduction%20II\\_BAR.pdf](http://weblink.charlottesville.org/public/0/edoc/793063/1_Introduction%20II_BAR.pdf)

### Chapter 2 Site Design and Elements

[http://weblink.charlottesville.org/public/0/edoc/793064/3\\_Chapter%20II%20Site%20Design%20and%20Elements\\_BAR.pdf](http://weblink.charlottesville.org/public/0/edoc/793064/3_Chapter%20II%20Site%20Design%20and%20Elements_BAR.pdf)

### Chapter 3 New Construction and Additions

[http://weblink.charlottesville.org/public/0/edoc/793065/4\\_Chapter%20III%20New%20Construction%20and%20Additions\\_BAR.pdf](http://weblink.charlottesville.org/public/0/edoc/793065/4_Chapter%20III%20New%20Construction%20and%20Additions_BAR.pdf)

### Chapter 4 Rehabilitation

[http://weblink.charlottesville.org/public/0/edoc/793066/5\\_Chapter%20IV%20Rehabilitation\\_BAR.pdf](http://weblink.charlottesville.org/public/0/edoc/793066/5_Chapter%20IV%20Rehabilitation_BAR.pdf)

### Chapter 5 Signs, Awnings, Vending, and Cafes

[http://weblink.charlottesville.org/public/0/edoc/793067/6\\_Chapter%20V%20Signs%20Awnings%20Vending%20and%20Cafes\\_BAR.pdf](http://weblink.charlottesville.org/public/0/edoc/793067/6_Chapter%20V%20Signs%20Awnings%20Vending%20and%20Cafes_BAR.pdf)

### Chapter 6 Public Improvements

[http://weblink.charlottesville.org/public/0/edoc/793068/7\\_Chapter%20VI%20Public%20Improvements\\_BAR.pdf](http://weblink.charlottesville.org/public/0/edoc/793068/7_Chapter%20VI%20Public%20Improvements_BAR.pdf)

### Chapter 7 Moving and Demolition

[http://weblink.charlottesville.org/public/0/edoc/793069/8\\_Chapter%20VII%20Moving%20and%20Demolition\\_BAR.pdf](http://weblink.charlottesville.org/public/0/edoc/793069/8_Chapter%20VII%20Moving%20and%20Demolition_BAR.pdf)

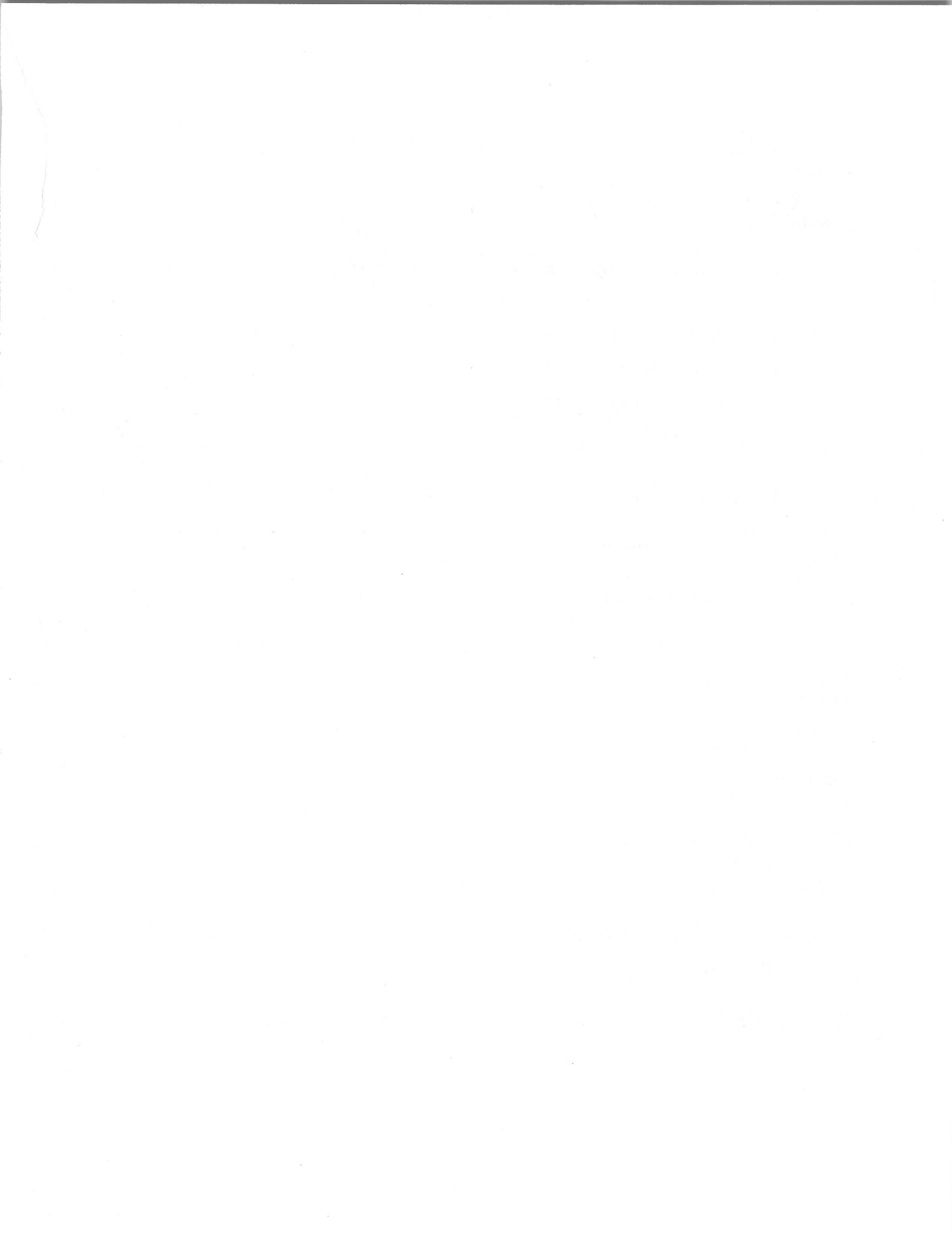

# 207 - 211 RIDGE STREET

CHARLOTTESVILLE, VA

DEMO REQUEST

MITCHELL / MATTHEWS ARCHITECTS

JANUARY 11, 2023



Request is hereby made to the City of Charlottesville's Board of Architectural Review for the demolition of 207 and 211 Ridge Street to allow for redevelopment of the site by the current Owner. As the attached photographs and site plan attempt to show, these buildings possess no redeeming architectural or historical value or qualities that warrant special consideration.

The following is an evaluation of the buildings based on the criteria for demolition as outlined in Chapter Seven of Charlottesville Architectural Design Control District Design Guidelines. We have also reviewed the city zoning ordinance and have addressed each of the demolition criteria. Responses are shown in italics.

According to City Code Section 34-278 the following factors shall be considered in determining whether or not to permit the moving, removing, encapsulation or demolition, in whole or in part, of a contributing structure of protected property:

(a) The historic, architectural or cultural significance, if any, of the specific structure or property, including, without limitation:

(1) The age of the structure;

***Response: The building at 207 Ridge Street was built in approximately 1965 (age of structure is 58 years), an addition was added in 1992 (age of structure is 31 years), refer to page 11 for extents. The building at 211 Ridge Street was existing per the 1992 drawings, however we have no record of its year of construction. Based on the Owner's recollections it occurred between 1965 and 1992, likely around 1980 based on review of the conditions (presumed age of structure is 43 years).***

(2) Whether it has been designated a National Historic Landmark, listed on the National Register of Historic Places or listed on the Virginia Landmarks Register;

***Response: No – none of the buildings have been individually listed on the National Register of Historic Places or the Virginia Landmarks Register.***

(3) Whether, and to what extent, the building or structure is associated with a historic person, architect or master craftsmen, or with a historic event;

***Response: There is no known historic event, person, architect or master craftsman associated with the structures at 207 and 211 Ridge Street.***

(4) Whether the building or structure or any of its features, represent an infrequent or the first or last remaining example within the city of a particular architectural style or feature;

***Response: None of the structures or features of 207 and 211 Ridge Street are known to represent an infrequent or first/last remaining example within the city of a particular architectural style or feature.***

(5) Whether the building or structure is of such old or distinctive design, texture or material that it could not be reproduced, or could be reproduced only with great difficulty;

***Response: In our opinion, the buildings and structures at 207 and 211 Ridge Street do not possess a distinctive design, texture, or material that could not be reproduced or that would warrant saving.***

(6) The degree to which distinguishing characteristics, qualities, features, or materials remain.

***Response: Currently, the buildings are intact, as originally designed, although the addition to 207 Ridge and of 211 Ridge significantly changed the original site conditions and access. The buildings and other site features at 207 and 211 Ridge Street will be removed in their entirety, in a phased manner to allow redevelopment to occur without displacement of the transient shelter, at 211 Ridge Street.***

(b) Whether, and to what extent, a contributing structure is linked, historically or aesthetically, to other buildings or structures within an existing major design control district, or is one of a group of properties within such a district whose concentration or continuity possesses greater significance than many of its component buildings.

***Response: There is no known historic or aesthetic link of the structures at 207 and 211 Ridge Street to the other buildings or structures within the ADC, and their demolition will not, we believe, adversely affect the character of the district.***

(c) The overall condition and structural integrity of the building or structure, as indicated by studies prepared by a qualified professional engineer and provided by the applicant or other information provided to the board.

***Response: No study of the overall condition and structural integrity of the buildings have been undertaken. The lack of architectural and/or historical significance of these buildings does not, in our opinion, warrant such an exercise.***

(d) Whether, and to what extent, the applicant proposes means, methods or plans for moving, removing or demolishing the structure or property that preserves portions, features or materials that are significant to the property's historic, architectural, or cultural values;

***Response: There are no known features, portions or materials of the buildings that have historic value and should be retained. It is proposed that the buildings will be demolished in their entirety.***

PID: 290022000  
CITY OF CHARLOTTESVILLE  
DB. 197, PG. 420  
#203 RIDGE STREET

MHD  
TOP=494.71  
INV IN=487.52 15" PVC (NW)  
INV IN=487.56 8" PVC (SW)  
INV OUT=487.51 15" RCP (SE)

#207  
3 STORY BRICK  
PID: 290029000  
THE SALVATION ARMY  
DB. 242, PG. 401  
DB. 328, PG. 54  
DB. 328, PG. 58  
DB. 337, PG. 266  
ZONED: WMEH  
1.21 AC.

PID: 290030000  
NOLAND PROPERTIES INC  
DB. 535, PG. 378  
#307 RIDGE STREET

- LEGEND**
- WATER METER
  - WATER VALVE
  - FIRE HYDRANT
  - WATER VAULT
  - SIAMESE CONNECTION
  - STORM MANHOLE (MHD)
  - DOWNSPOUT
  - DRAINAGE DIRECTION ARROW
  - SANITARY MANHOLE (MHS)
  - CLEANOUT
  - SIGN
  - AC UNIT
  - BOLLARD
  - GAS VALVE
  - ELECTRIC VAULT
  - LIGHT POLE
  - UTILITY POLE
  - GUY ANCHOR

- (F) ○○ PROPERTY CORNER FOUND (AS NOTED)
- FENCE
  - EDGE-OF-PAVEMENT
  - SAN SANITARY LINE
  - STORM LINE
  - OHU OVERHEAD POWER
  - GUARD RAIL
  - UNDERGROUND GAS (AS MARKED)
  - UNDERGROUND FIBER OPTIC (AS MARKED)
  - UFG UNDERGROUND TELEPHONE (AS MARKED)
  - UGT UNDERGROUND TELEPHONE (AS MARKED)
  - W UNDERGROUND WATER (AS MARKED)
  - UGP UNDERGROUND POWER (AS MARKED)
  - DWS DETECTABLE WARNING STRIP
  - CONC CONCRETE
  - SWLK SIDEWALK
  - C&G CURB AND GUTTER
  - EP EDGE OF PAVEMENT
  - DYL DOUBLE YELLOW LINE
  - SWL SOLID WHITE LINE
  - TD TRENCH DRAIN
  - DECIDUOUS TREE (DEC)

**SURVEY NOTES:**

1. HORIZONTAL DATUM IS BASED ON NAD83 (NA2011), VIRGINIA STATE GRID, SOUTH ZONE. VERTICAL DATUM IS BASED ON NAVD88. DATUM ESTABLISHED THROUGH NETWORK RTK GPS (LEICA SmartNET) OBSERVATIONS.
2. TOPOGRAPHIC DATA DEPICTED BASED ON A CURRENT FIELD SURVEY BY THIS FIRM, COMPLETED MAY 25, 2021.
3. THIS IS NOT A BOUNDARY SURVEY; BOUNDARY SHOWN HEREON IS COMPILED FROM DEEDS AND PLATS OF RECORD IN THE CLERK'S OFFICE OF CITY OF CHARLOTTESVILLE, VIRGINIA, AND RECOVERED MONUMENTS AND FIELD OBSERVATIONS.
4. BASED ON FEMA FLOOD INSURANCE RATE MAP (FIRM), MAP NO. 51003C0288D, PANEL 286 OF 575, EFFECTIVE DATE FEBRUARY 4, 2005.
5. MISS UTILITY TICKET INITIATED; TICKET NO. A113901458. NO UNDERGROUND UTILITY INVESTIGATION BEYOND INFORMATION PROVIDED VIA MISS UTILITY HAS BEEN CONDUCTED BY THIS FIRM.
6. CONTOUR INTERVAL = 1'
7. SEE DB. 393, PG. 709 FOR VEPCO EASEMENT.
8. SEE DB. 590, PG. 190 FOR VEPCO EASEMENT.

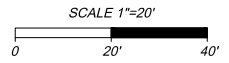

THIS TOPOGRAPHIC SURVEY WAS COMPLETED UNDER THE DIRECT AND RESPONSIBLE CHARGE OF JOSEPH C. MEDLEY FROM AN ACTUAL GROUND SURVEY MADE UNDER MY SUPERVISION; THAT THE ORIGINAL DATA WAS OBTAINED ON THE FOLLOWING DATES: MAY 20-25 2021. THIS BASE-MAP AND DIGITAL GEOSPATIAL DATA INCLUDING METADATA MEETS MINIMUM ACCURACY STANDARDS UNLESS OTHERWISE NOTED.

EXISTING CONDITIONS  
**TOPOGRAPHIC SURVEY**  
ON THE LANDS OF  
**THE SALVATION ARMY**  
TAX MAP PARCEL 290029000  
CITY OF CHARLOTTESVILLE, VIRGINIA  
FIFEVILLE PLANNING NEIGHBORHOOD

	CITY OF CHARLOTTESVILLE, VA
Date: May 28, 2021	Scale: 1" = 20'
Sheet 1 of 1	J.N.: 48482
Drawn by: DWJ / JCM	Checked by: JCM
LAST REVISED: _	

**TIMMONS GROUP**

THIS DRAWING PREPARED AT THE  
STANTON OFFICE  
28 Imperial Drive | Staunton, VA 24401  
TEL 540.885.0920 FAX 540.560.1016 www.timmons.com

YOUR VISION ACHIEVED THROUGH OURS.

Y:\0048482-Salvation\_Army\_Additional\DWG\482\_XPS\JRV\_2.dwg | Plotted on 6/11/2021 1:19 PM | by Joe Medley

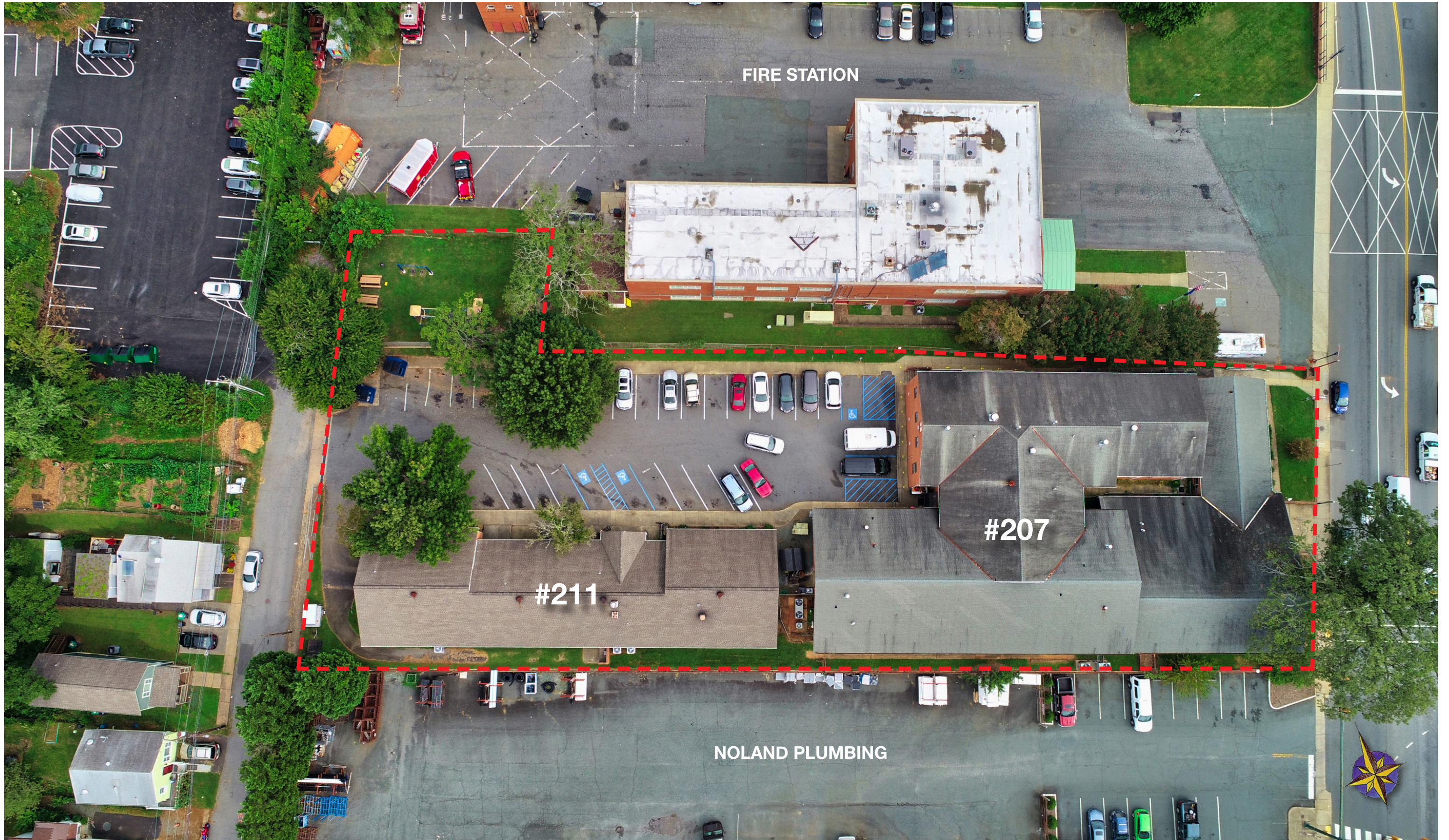

FIRE STATION

#207

#211

NOLAND PLUMBING

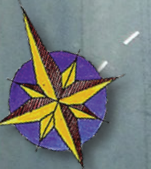



# AERIAL FROM NORTHEAST

All grades, counts and quantities are approximate and will change as design proceeds.



## AERIAL FROM SOUTHEAST

All grades, counts and quantities are approximate and will change as design proceeds.



## AERIAL FROM SOUTHWEST

*All grades, counts and quantities are approximate and will change as design proceeds.*



Salvation Army  
Charlottesville, VA

12.28.2022

## EXTERIOR PHOTOS FRONT (#207)

*All grades, counts and quantities are approximate and will change as design proceeds.*

**MITCHELL / MATTHEWS**  
ARCHITECTS & PLANNERS

434.979.7550

© 2023



#207



#211



#207 & #211



#211



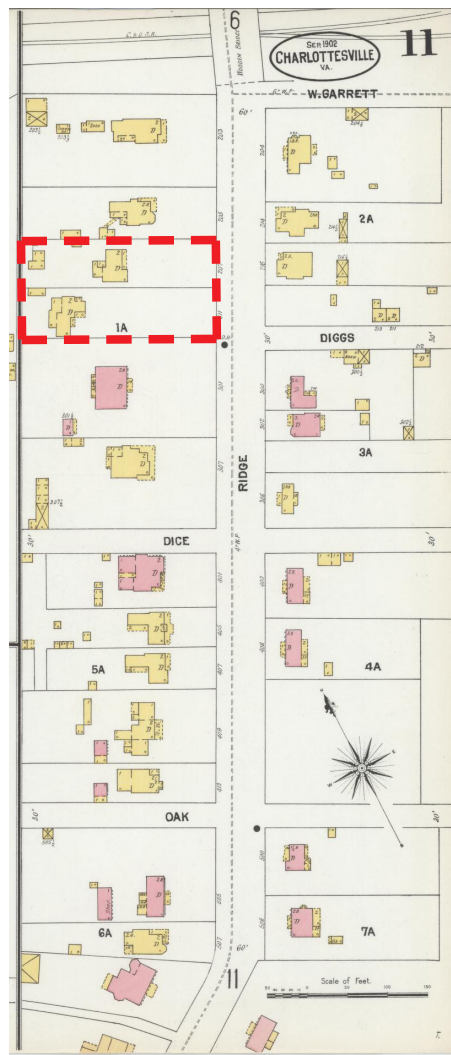

Sept 1902

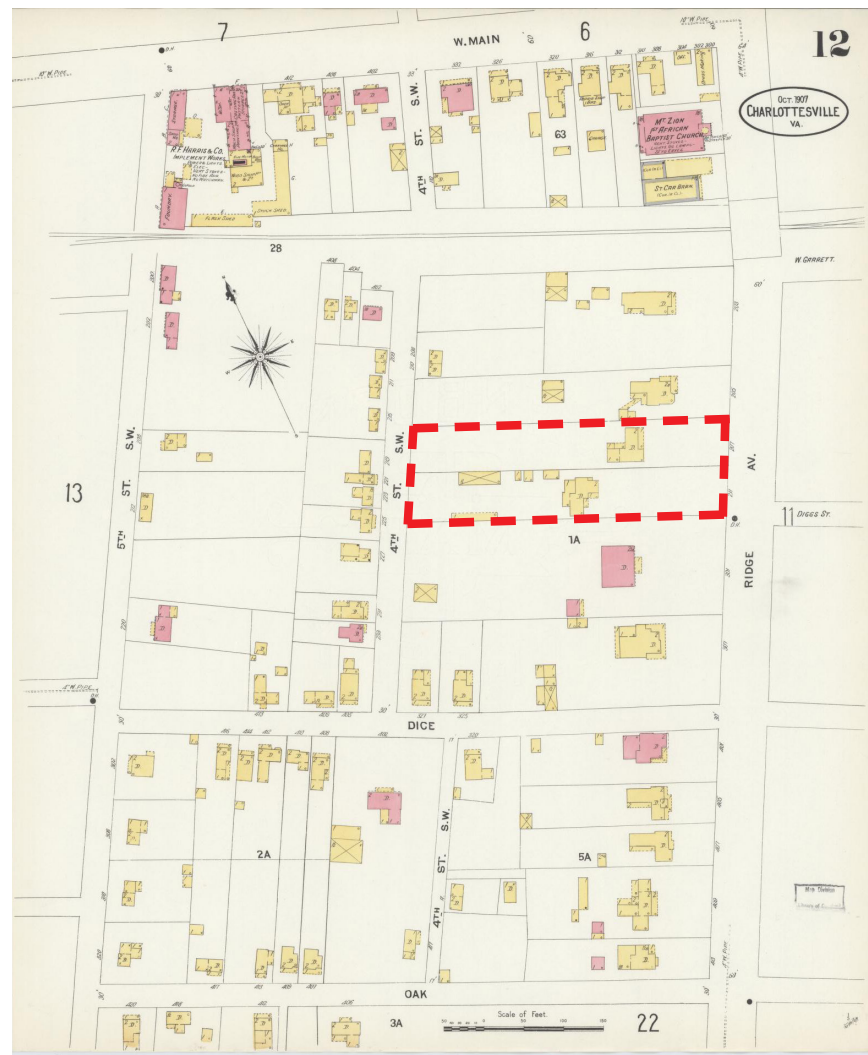

Oct 1907

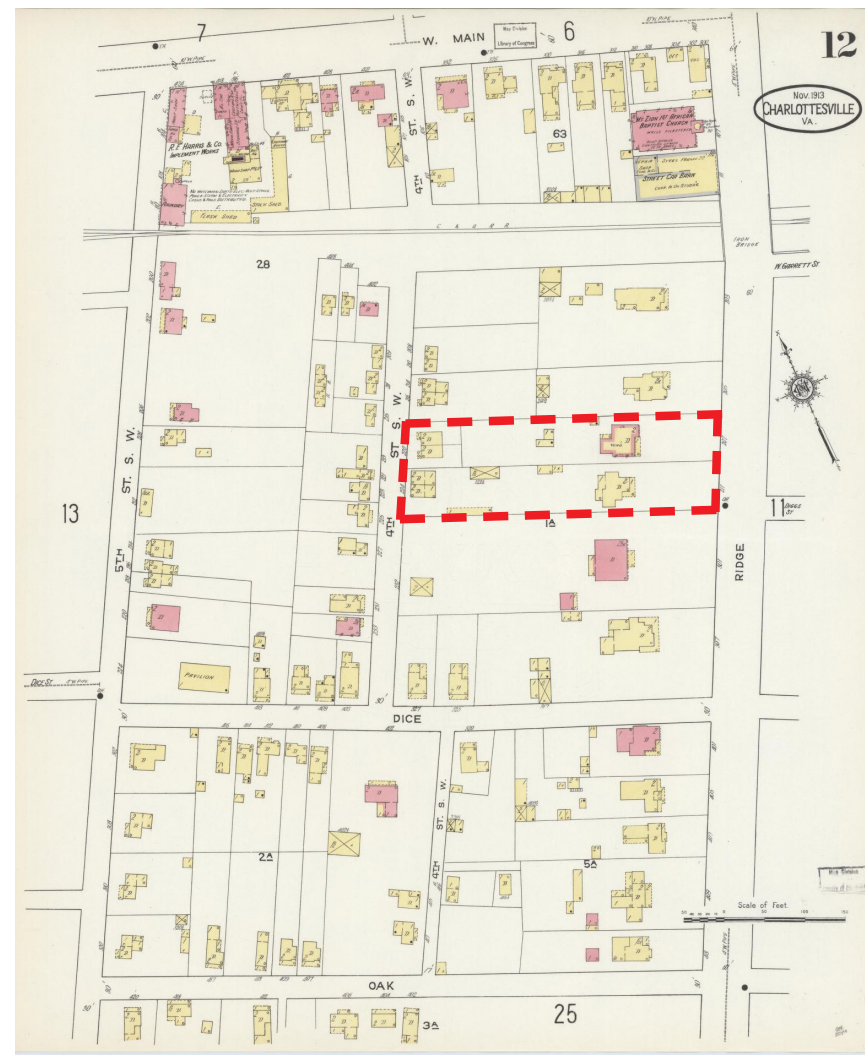

Nov 1913



Feb 1920

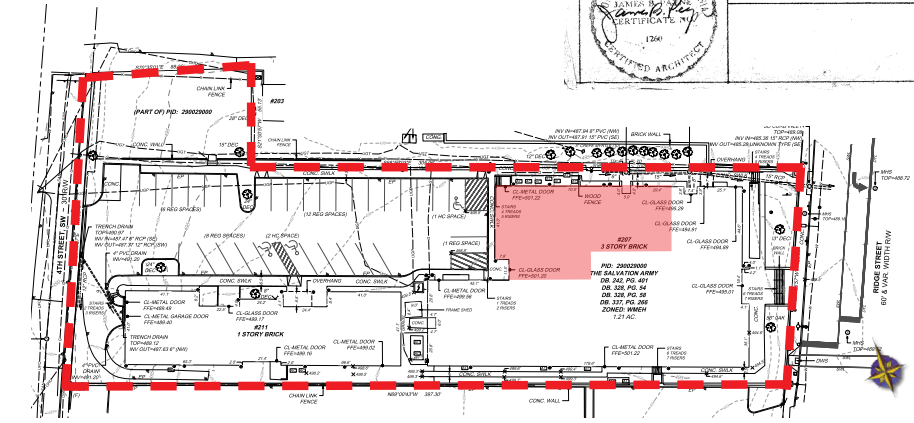
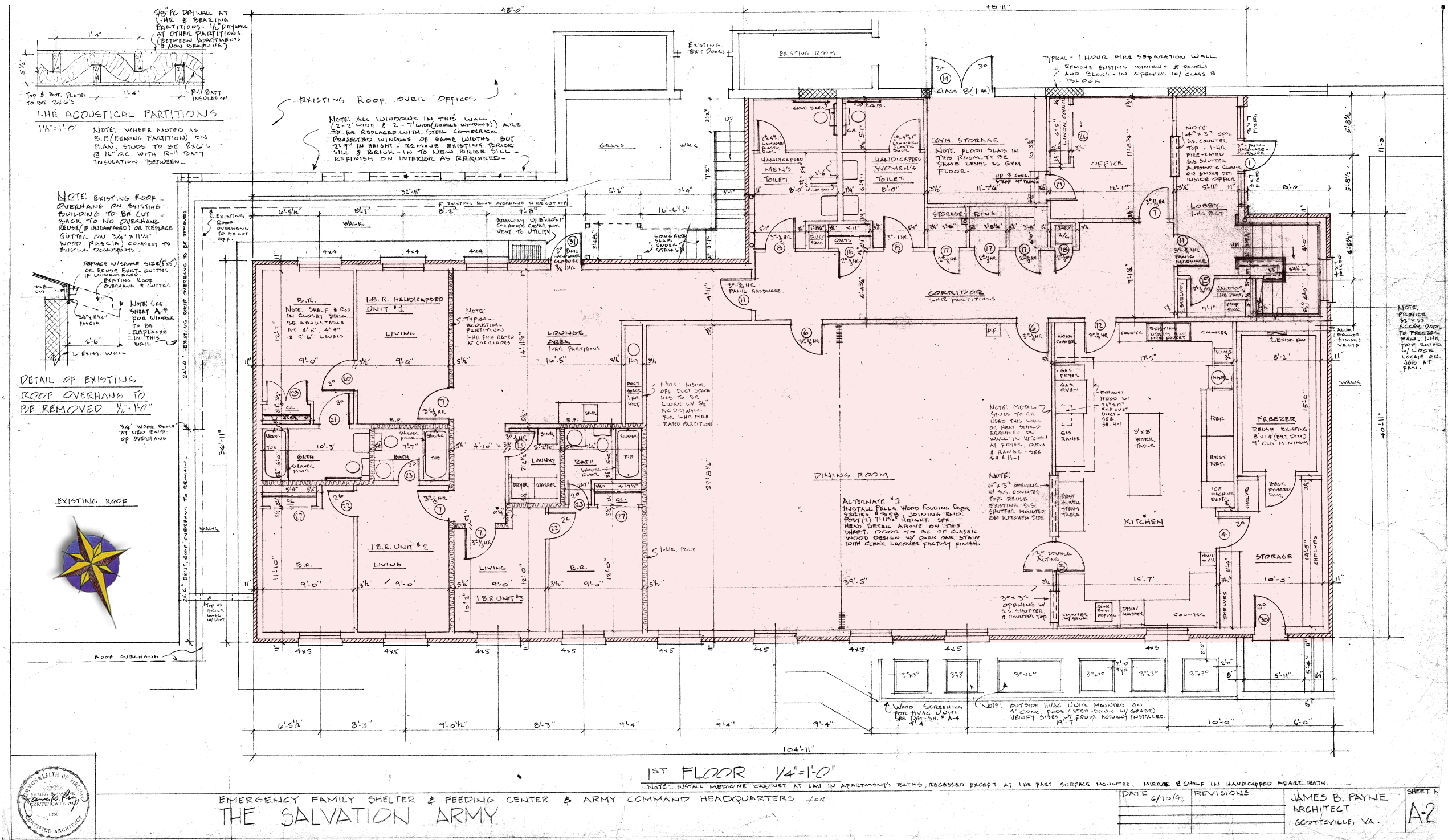

1992 CONSTRUCTION DRAWINGS SHOW #211 RIDGE AVE AS EXISTING CONSTRUCTION, BUT NO DATE IS PROVIDED. ORIGINAL CONSTRUCTION FOR #207 IS NOTED AS 1965 ON THESE DRAWINGS.

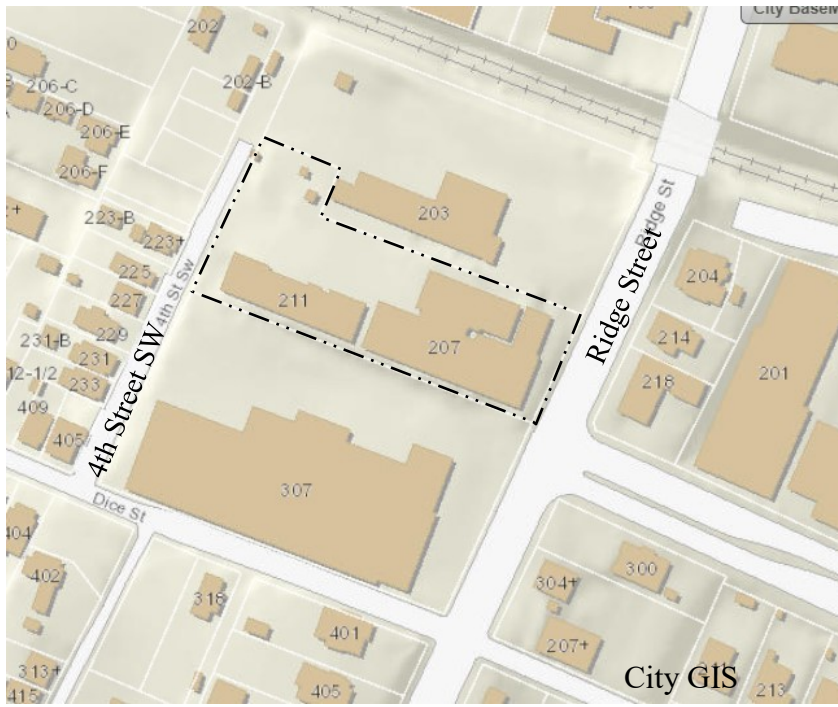





Google street view



Google street view



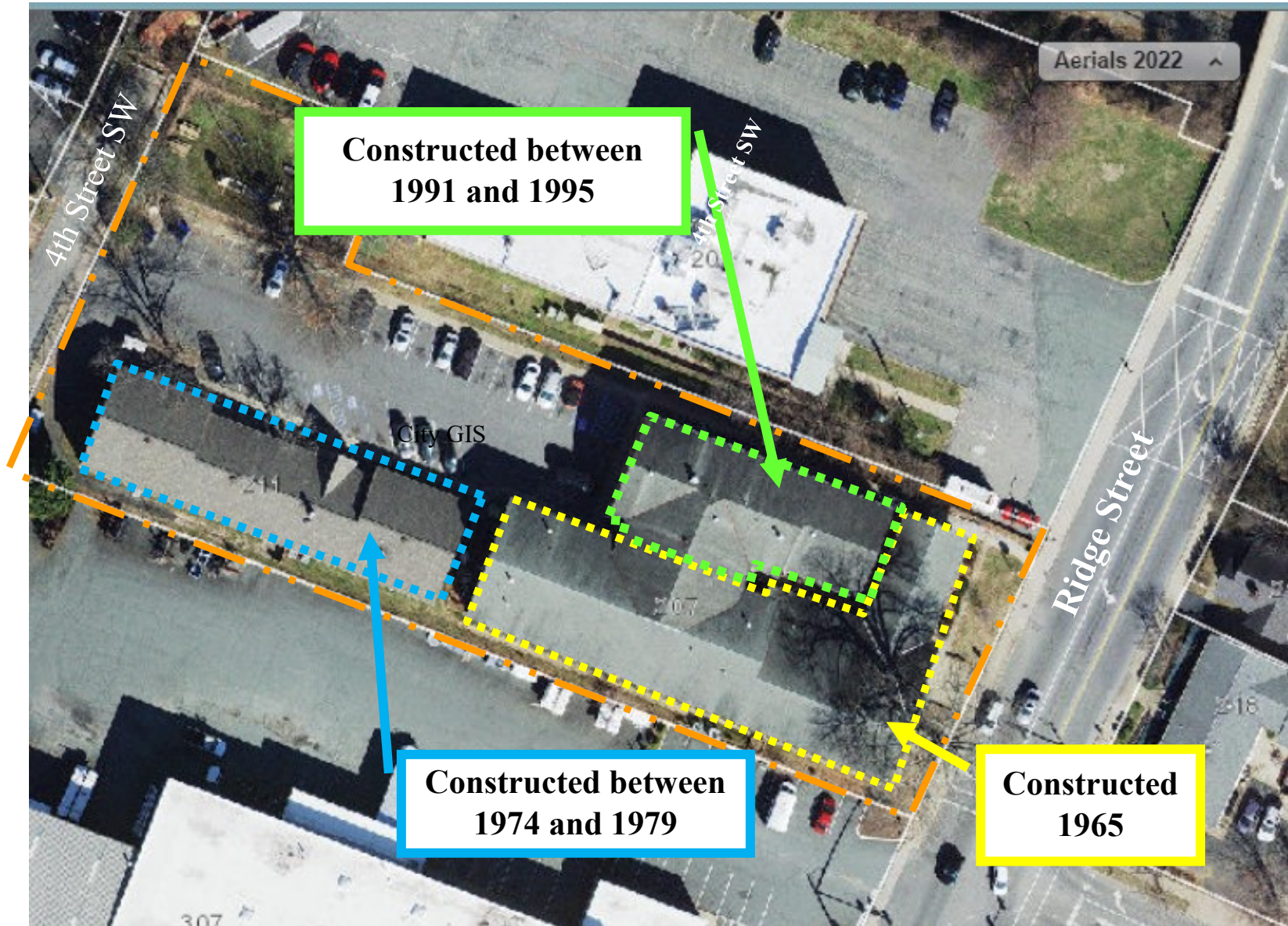

City GIS

# 207 - 211 RIDGE STREET

S U P P L E M E N T A

TREE PROTECTION REQUIREMENTS



PID: 290022000  
 CITY OF CHARLOTTESVILLE  
 DB. 197, PG. 420  
 #203 RIDGE STREET

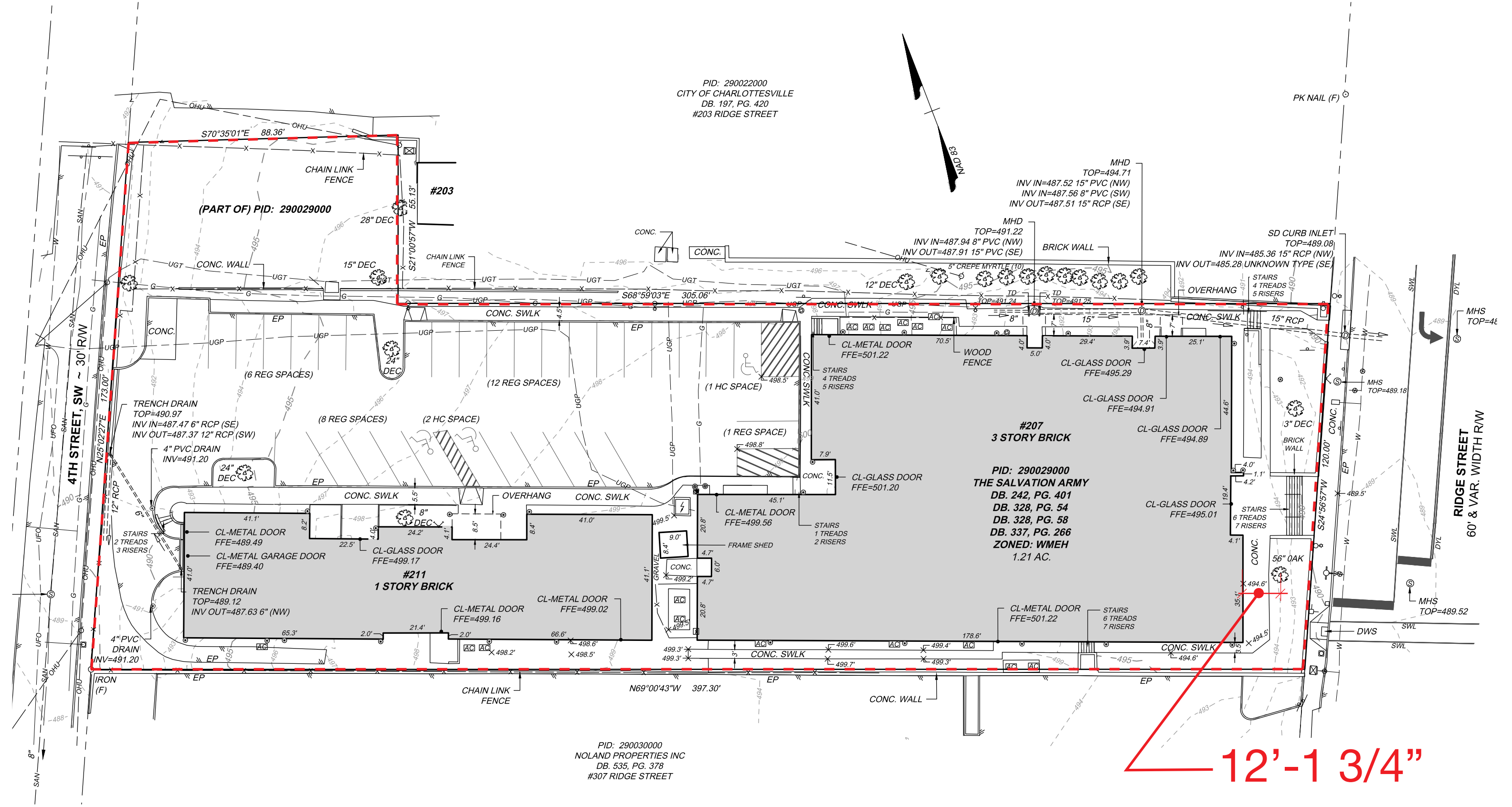

**12'-1 3/4"**  
 DISTANCE FROM TREE  
 TO EXISTING BUILDING

**EXISTING SURVEY DISTANCE TO TREE**

All grades, counts and quantities are approximate and will change as design proceeds.

PID: 290022000  
 CITY OF CHARLOTTESVILLE  
 DB. 197, PG. 420  
 #203 RIDGE STREET

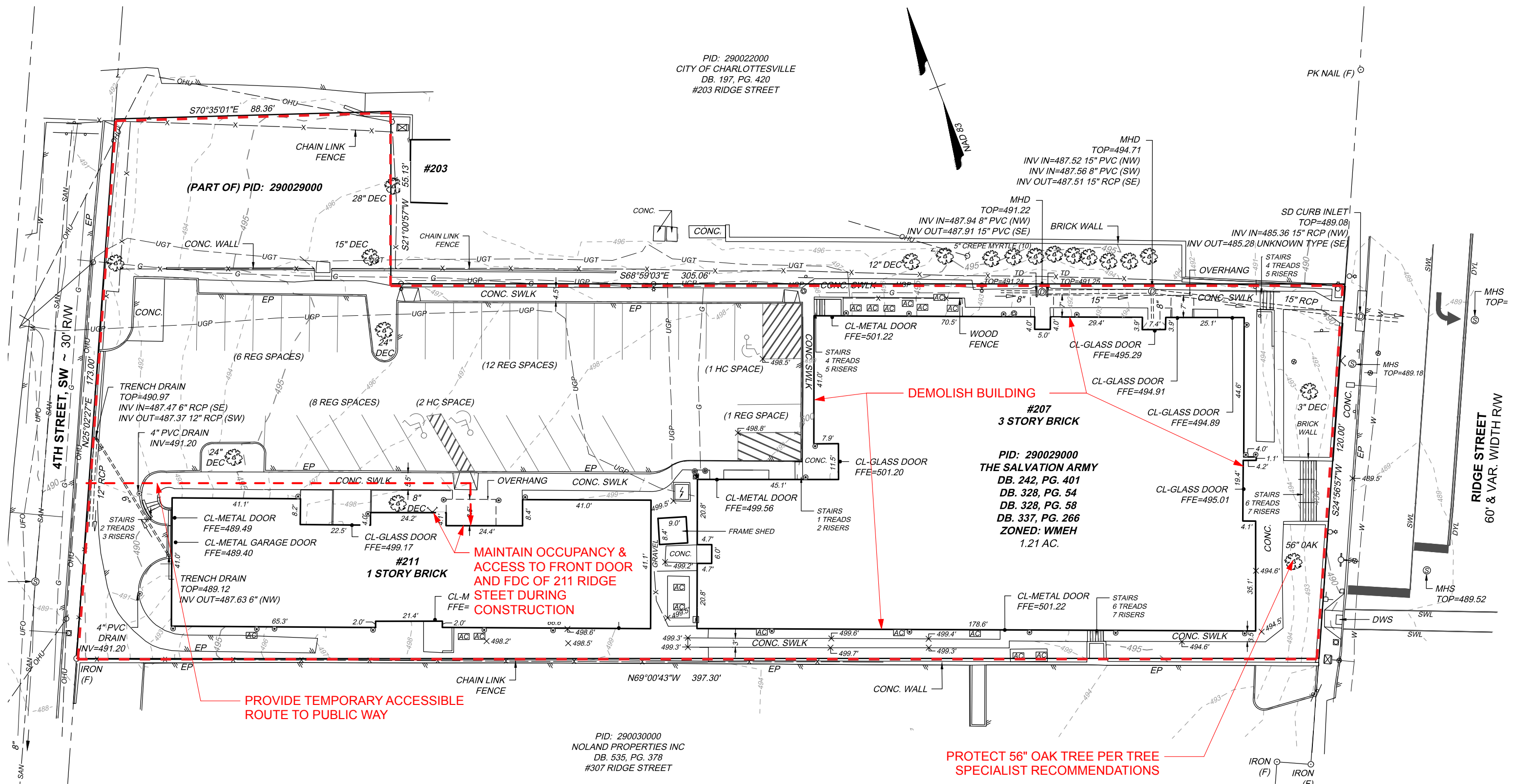

# PHASE 1 DEMOLITION PLAN

All grades, counts and quantities are approximate and will change as design proceeds.

PID: 290022000  
CITY OF CHARLOTTESVILLE  
DB. 197, PG. 420  
#203 RIDGE STREET

PK NAIL (F)

**32'-3 1/2"**

**DISTANCE FROM TREE TO PROPOSED FOUNDATION**

**36'-3"**

**DISTANCE FROM TREE TO PROPOSED PORCH FOOTINGS**

**SHELTER TO REMAIN OPERABLE DURING REDEVELOPMENT**

PID: 290030000  
NOLAND PROPERTIES INC  
DB. 535, PG. 378  
#307 RIDGE STREET

# PROPOSED FOOTPRINT OVER EXISTING SURVEY

All grades, counts and quantities are approximate and will change as design proceeds.

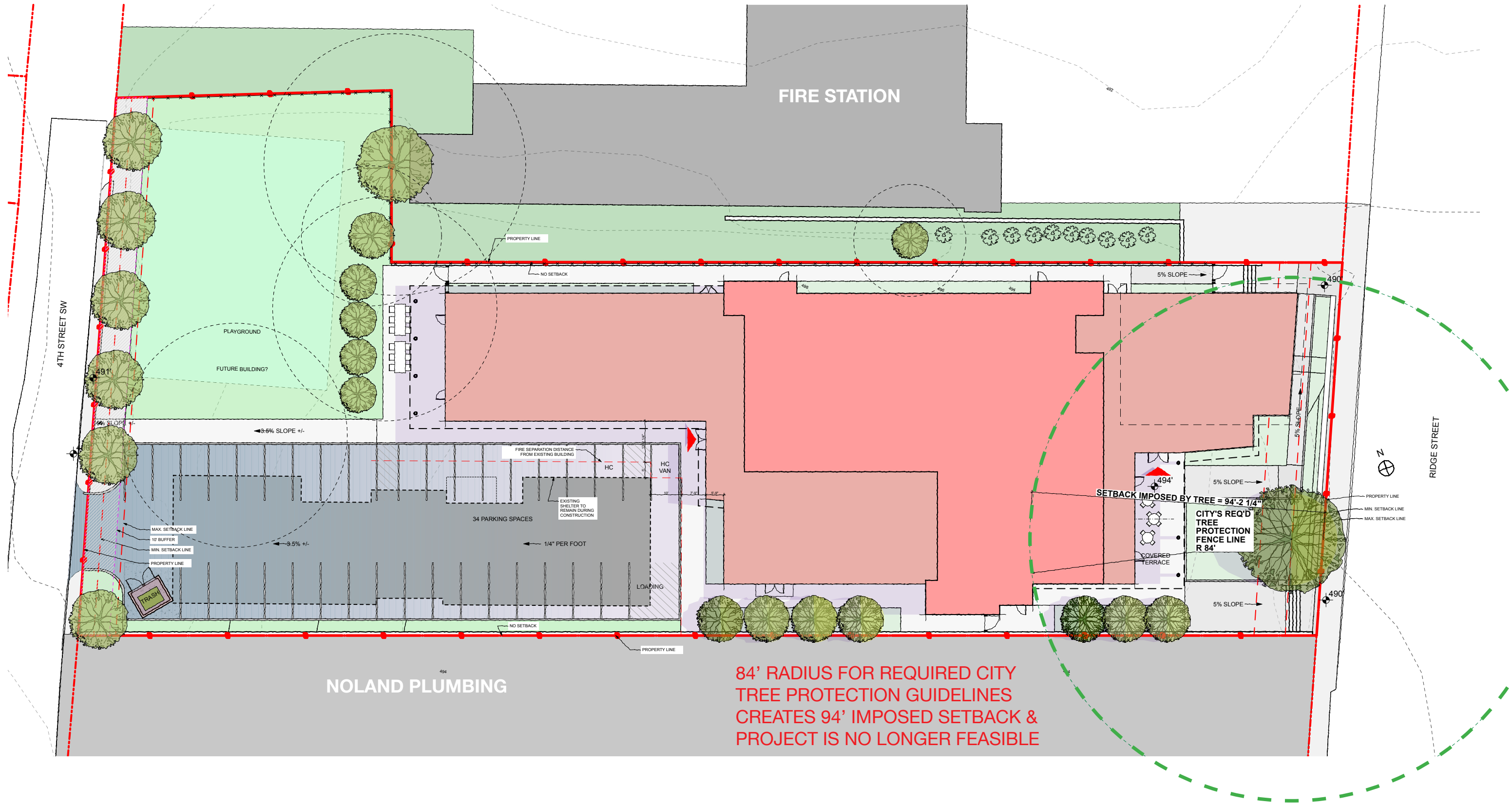



## CONCEPTUAL RENDERING SHOWING INTENT TO “SAVE” THE TREE

*All grades, counts and quantities are approximate and will change as design proceeds.*